

brother®

USER'S GUIDE



MFC-9840CDW

Version B

USA/CAN

If you need to call Customer Service

Please complete the following information for future reference:

Model Number: MFC-9840CDW

Serial Number: ¹ _____

Date of Purchase: _____

Place of Purchase: _____

¹ **The serial number is on the back of the unit. Retain this User's Guide with your sales receipt as a permanent record of your purchase, in the event of theft, fire or warranty service.**

Register your product on-line at

<http://www.brother.com/registration>

By registering your product with Brother, you will be recorded as the original owner of the product. Your registration with Brother:

- may serve as confirmation of the purchase date of your product should you lose your receipt;
- may support an insurance claim by you in the event of product loss covered by insurance; and,
- will help us notify you of enhancements to your product and special offers.

The most convenient and efficient way to register your new product is online at <http://www.brother.com/registration>

Brother numbers

IMPORTANT

For technical help, you must call the country where you bought the machine. Calls must be made *from within* that country.

Register your product

By registering your product with Brother International Corporation, you will be recorded as the original owner of the product. Your registration with Brother:

- may serve as confirmation of the purchase date of your product should you lose your receipt;
- may support an insurance claim by you in the event of product loss covered by insurance; and,
- will help us notify you of enhancements to your product and special offers.

Please complete and fax the Brother Warranty Registration And Test Sheet or, for your convenience and most efficient way to register your new product, register on-line at

<http://www.brother.com/registration>

FAQs (frequently asked questions)

The Brother Solutions Center is our one-stop resource for all your Fax Machine/Multi-Function Center needs. You can download the latest software and utilities and read FAQs and troubleshooting tips to learn how to get the most from your Brother product.

<http://solutions.brother.com>



Note

You can check here for Brother driver updates.

To keep your machine performance up to date, check here for the latest firmware upgrade (for Windows® only).

For Customer Service

In USA: 1-877-BROTHER (1-877-276-8437)

1-901-379-1215 (fax)

In Canada: 1-877-BROTHER

(514) 685-4898 (fax)

Service Center Locator (USA only)

For the location of a Brother authorized service center, call 1-877-BROTHER (1-877-276-8437).

Service Center Locations (Canada only)

For the location of a Brother authorized service center, call 1-877-BROTHER.

Ordering accessories and supplies

For best quality results use only genuine Brother accessories, which are available at most Brother retailers. If you cannot find the accessory you need and you have a Visa, MasterCard, Discover, or American Express credit card, you can order accessories directly from Brother. (You can visit us online for a complete selection of the Brother accessories and supplies that are available for purchase.)

In USA: 1-877-552-MALL (1-877-552-6255)
1-800-947-1445 (fax)

<http://www.brothermall.com>

In Canada: 1-877-BROTHER

<http://www.brother.ca>

Description	Item
Toner Cartridge Standard	Black: TN-110BK (Prints approx. 2,500 pages)
	Cyan: TN-110C (Prints approx. 1,500 pages)
	Magenta: TN-110M (Prints approx. 1,500 pages)
	Yellow: TN-110Y (Prints approx. 1,500 pages)
Toner Cartridge High Yield	Black: TN-115BK (Prints approx. 5,000 pages)
	Cyan: TN-115C (Prints approx. 4,000 pages)
	Magenta: TN-115M (Prints approx. 4,000 pages)
	Yellow: TN-115Y (Prints approx. 4,000 pages)
Drum Unit	DR-110CL
Belt Unit	BU-100CL
Waste Toner Box	WT-100CL
Telephone Line Cord	LG3077001
Paper Tray #2 (Option)	LT-100CL
User's Guide	LS3218001 (English for USA and Canada)
	LP7074002 (French for Canada)
Quick Setup Guide	LP7059001 (English for USA and Canada)
	LP7059002 (French for Canada)

Notice - Disclaimer of Warranties (USA and Canada)

BROTHER'S LICENSOR(S), AND THEIR DIRECTORS, OFFICERS, EMPLOYEES OR AGENTS (COLLECTIVELY BROTHER'S LICENSOR) MAKE NO WARRANTIES, EXPRESS OR IMPLIED, INCLUDING WITHOUT LIMITATION THE IMPLIED WARRANTIES OF MERCHANTABILITY AND FITNESS FOR A PARTICULAR PURPOSE, REGARDING THE SOFTWARE. BROTHER'S LICENSOR(S) DOES NOT WARRANT, GUARANTEE OR MAKE ANY REPRESENTATIONS REGARDING THE USE OR THE RESULTS OF THE USE OF THE SOFTWARE IN TERMS OF ITS CORRECTNESS, ACCURACY, RELIABILITY, CURRENTNESS OR OTHERWISE. THE ENTIRE RISK AS TO THE RESULTS AND PERFORMANCE OF THE SOFTWARE IS ASSUMED BY YOU. THE EXCLUSION OF IMPLIED WARRANTIES IS NOT PERMITTED BY SOME STATES IN THE USA AND SOME PROVINCES IN CANADA. THE ABOVE EXCLUSION MAY NOT APPLY TO YOU.

IN NO EVENT WILL BROTHER'S LICENSOR(S) BE LIABLE TO YOU FOR ANY CONSEQUENTIAL, INCIDENTAL OR INDIRECT DAMAGES (INCLUDING DAMAGES FOR LOSS OF BUSINESS PROFITS, BUSINESS INTERRUPTION, LOSS OF BUSINESS INFORMATION, AND THE LIKE) ARISING OUT OF THE USE OR INABILITY TO USE THE SOFTWARE EVEN IF BROTHER'S LICENSOR HAS BEEN ADVISED OF THE POSSIBILITY OF SUCH DAMAGES. BECAUSE SOME STATES IN THE USA AND SOME PROVINCES IN CANADA DO NOT ALLOW THE EXCLUSION OR LIMITATION OF LIABILITY FOR CONSEQUENTIAL OR INCIDENTAL DAMAGES, THE ABOVE LIMITATIONS MAY NOT APPLY TO YOU. IN ANY EVENT BROTHER'S LICENSOR'S LIABILITY TO YOU FOR ACTUAL DAMAGES FROM ANY CAUSE WHATSOEVER, AND REGARDLESS OF THE FORM OF THE ACTION (WHETHER IN CONTRACT, TORT (INCLUDING NEGLIGENCE), PRODUCT LIABILITY OR OTHERWISE), WILL BE LIMITED TO \$50.

Compilation and Publication Notice

Under the supervision of Brother Industries, Ltd., this manual has been compiled and published, covering the latest product descriptions and specifications.

The contents of this manual and the specifications of this product are subject to change without notice.

Brother reserves the right to make changes without notice in the specifications and materials contained herein and shall not be responsible for any damages (including consequential) caused by reliance on the materials presented, including but not limited to typographical and other errors relating to the publication.

Brother® Color Laser One-Year On-Site Limited Warranty (USA only)

Who is covered:

- This limited warranty (“warranty”) is given only to the original end-use/retail purchaser (referred to in this warranty as “Original Purchaser”) of the accompanying product, consumables and accessories (collectively referred to in this warranty as “this Product”).
- If you purchased a product from someone other than an authorized Brother reseller in the United States or if the product was used (including but not limited to floor models or refurbished product), prior to your purchase you are not the Original Purchaser and the product that you purchased is not covered by this warranty.

What is covered:

- This Product includes a Machine and Consumable and Accessory Items. Consumable and Accessory Items include but are not limited to Toner Cartridges, Drum Unit, Belt Unit, and Waste Toner Box.
- Except as otherwise provided herein, Brother warrants that the Machine and the accompanying Consumable and Accessory Items will be free from defects in materials and workmanship, when used under normal conditions.
- This warranty applies only to products purchased and used in the United States. For products purchased in, but used outside, the United States, this warranty covers only warranty service within the United States (and does not include shipping outside the United States).

What is the length of the Warranty Periods:

- Machines: one year from the original purchase date.
- Accompanying Consumable and Accessory Items: 90 days from the original purchase date or the rated life of consumable, whichever comes first.

What is NOT covered:

This warranty does not cover:

- 1 Physical damage to this Product;
- 2 Damage caused by improper installation, improper or abnormal use, misuse, neglect or accident (including but not limited to transporting this Product without the proper preparation and/or packaging);
- 3 Damage caused by another device or software used with this Product (including but not limited to damage resulting from use of non Brother®-brand parts and Consumable and Accessory Items);
- 4 Consumable and Accessory Items that expired in accordance with a rated life;
- 5 Problems arising from other than defects in materials or workmanship; and,
- 6 Normal Periodic Maintenance Items, such as Paper Feeding Kit, Fuser and Laser Units.

This limited warranty is VOID if this Product has been altered or modified in any way (including but not limited to attempted warranty repair without authorization from Brother and/or alteration/removal of the serial number).

What to do if you think your Product is eligible for warranty service:

Report your issue to our Customer Service Hotline at 1-877-BROTHER (1-877-276-8437) or to a Brother Authorized Service Center within the applicable warranty period. Supply Brother or the Brother Authorized Service Center with a copy of your dated bill of sale showing that this Product was purchased within the U.S. For the name of local Brother Authorized Service Center(s), call 1-877-BROTHER (1-877-276-8437) or visit www.brother-usa.com.

What Brother will ask you to do:

After contacting Brother or a Brother Authorized Service Center, you may be required to provide information pertaining to the defect or malfunction of this Product.

Brother® Color Laser One-Year On-Site Limited Warranty (USA only)

What Brother will do:

If the problem reported concerning your Machine and/or accompanying Consumable and Accessory Items is covered by this warranty and if you first reported the problem to Brother or an Authorized Service Center within the applicable warranty period, Brother or its Authorized Service Center will evaluate your report of a possible defect to determine whether a defect exists, and if it does exist, Brother or an Authorized Service Center will provide "On-site Warranty Service" during "Normal Working Hours" and will repair the Machine and/or accompanying Consumable and Accessory Items at no charge to you for parts or labor. "On-site Warranty Service" shall consist of the remedial service, as necessitated by normal usage, to restore this product to good operating condition at your location and does not guarantee uninterrupted operation of this Product. "Normal Working Hours" shall mean 9:00am to 5:00pm (local time), Monday through Friday, excluding legal and local holidays observed by Brother or the Authorized Service Center.

If the Machine and/or accompanying Consumable and Accessory Items are not covered by this warranty, you will be charged for any service and/or replacement parts/products at Brother's or the Authorized Service Center's then current published rates.

The foregoing are your sole (i.e., only) and exclusive remedies under this warranty.

What you must provide:

Reasonable cooperation with the Brother Representative in troubleshooting as they diagnose the problem, provide access to this Product at reasonable times and provide adequate working space including heat, light, ventilation, electric current and outlets for the use of the Brother representative.

Limitations:

Brother is not responsible for damage to or loss of any equipment, media, programs or data related to the use of this Product.

Except for the repair as described above, Brother shall not be liable for any direct, indirect, incidental or consequential damages or specific relief. Because some states do not allow the exclusion or limitation of consequential or incidental damages, the above limitation may not apply to you.

THIS WARRANTY IS GIVEN IN LIEU OF ALL OTHER WARRANTIES, WRITTEN OR ORAL, WHETHER EXPRESSED BY AFFIRMATION, PROMISE, DESCRIPTION, DRAWING, MODEL OR SAMPLE. ANY AND ALL WARRANTIES OTHER THAN THIS ONE, WHETHER EXPRESS OR IMPLIED, INCLUDING IMPLIED WARRANTIES OF MERCHANTABILITY AND FITNESS FOR A PARTICULAR PURPOSE, ARE HEREBY DISCLAIMED.

- This Limited Warranty is the only warranty that Brother is giving for this Product. It is the *final expression and the exclusive and only statement* of Brother's obligations to you. It replaces all other agreements and understandings that you may have with Brother or its representatives.
- This warranty gives you certain rights and you may also have other rights that may vary from state to state.
- This Limited Warranty (and Brother's obligation to you) may not be changed in any way unless you and Brother sign the same piece of paper in which we (1) refer to this Product and your bill of sale date, (2) describe the change to this warranty and (3) agree to make that change.

**BROTHER LASER PRINTER / MULTIFUNCTION CENTER®/
FAX ON-SITE WARRANTY
(Canada only)**

For a limited on-site warranty of 1 year labour and parts from the date of purchase, Brother International Corporation (Canada) Ltd. ("Brother"), or its authorized on-site service providers, will repair or replace (at Brother's sole discretion) this Laser Printer/MFC/Fax machine free of charge if defective in material or workmanship. This warranty applies only to products purchased and used in Canada. This limited Warranty does not include cleaning, consumables (including, without limitation, toner cartridges and drum units, OPC belts, fixing units, print heads, paper feed rollers, transfer rolls, cleaning rollers, waste toner packs, oil bottles) or damage caused by accident, neglect, misuse or improper installation or operation or any damage caused from service, maintenance, modifications, or tampering by anyone other than a Brother Authorized Service Representative, or if shipped out of the country. The use of supplies or consumable items that are non-Brother products may void your warranty. This limited warranty ceases when this machine is rented, sold, or otherwise disposed of. Operation of the laser printer/MFC/Fax in excess of the specifications or with the Serial Number or Rating Label removed shall be deemed abuse and all repairs thereafter shall be the sole liability of the end-user/purchaser. The Laser Printer/MFC/Fax machine will be serviced on-site. Canadian Proof of Purchase in the form of a Sales Receipt must be provided if requested by the service personnel. In the event that geographical location does not permit us to provide on-site service to you, Brother reserves the right to exchange your machine with an equivalent or better one through a courier service.

When shipping or transporting your Laser Printer/MFC/Fax machine, please refer to your Operation Manual for the proper packaging procedures. Failure to remove the Toner Cartridge (and Toner Drum Unit, waste toner packs or oil bottles on applicable models) during shipping or transport will cause severe damage to the Laser Printer/MFC/Fax machine and will void the Warranty.

Improper packaging may cause severe damage to the machine during shipping and will void the warranty.

BROTHER DISCLAIMS ALL OTHER WARRANTIES EXPRESSED OR IMPLIED INCLUDING, WITHOUT LIMITATIONS, ANY IMPLIED WARRANTIES OF MERCHANTABILITY OR FOR A PARTICULAR PURPOSE, EXCEPT TO THE EXTENT THAT ANY WARRANTIES IMPLIED BY LAW CANNOT BE VALIDLY WAIVED.

No oral or written information, advice or representation provided by Brother, its Authorized Service Centres, Distributors, Dealers, Agents or employees, shall create another warranty or modify this warranty. The warranty states Brother's entire liability and your exclusive remedy against Brother for any failure of the Laser Printer/MFC/Fax machine to operate properly.

Neither Brother nor anyone else involved in the development, production, or delivery of this Laser Printer/MFC/Fax machine shall be liable for any indirect, incidental, special, consequential, exemplary, or punitive damages, including lost profits, arising from the use of or inability to use the product, even if advised by the end user/purchaser of the possibility of such damages. Since some Provinces do not allow the above limitation of liability, such limitation, may not apply to you.

This Limited Warranty gives you specific legal rights and you may also have other rights which vary from Province to Province.

Warranty Service is available at Brother Authorized Service Centres throughout Canada. For Technical Assistance or for the name and location of your nearest Authorized Service Centre call 1-877-Brother.

brother®

Internet support: support@brother.ca or browse Brother's Web Site www.brother.ca.

Table of Contents

Section I General

1	General information	2
	Using the documentation	2
	Symbols and conventions used in the documentation	2
	Accessing the User's Guides	2
	Viewing documentation	3
	Accessing Brother support (for Windows®)	5
	Control panel overview	6
	Status LED indications	9
2	Loading paper and documents	11
	Acceptable paper and other media	11
	Recommended paper	11
	Type and size of paper	11
	Handling and using special paper	13
	Unprintable area	16
	Unprintable area for copies	16
	Unprintable area when printing from a computer	17
	Loading paper and envelopes	17
	Loading documents	20
	Using the ADF (automatic document feeder)	20
	Using the scanner glass	21
3	General setup	22
	Mode timer	22
	Paper settings	22
	Paper type	22
	Paper size	23
	Tray use in copy mode	23
	Tray use in fax mode	24
	Tray use in print mode	24
	Volume settings	25
	Ring volume	25
	Beeper volume	25
	Speaker volume	25
	Automatic daylight savings time	26
	Ecology features	26
	Toner save	26
	Sleep time	26
	Turning off the scanner lamp	26
	LCD contrast	27
	Dial Prefix	27

4	Security features	28
	Security.....	28
	Setting lock.....	28
	Secure Function Lock.....	29

Section II Fax

5	Sending a fax	34
	How to fax.....	34
	Entering fax mode.....	34
	Sending a single-sided fax from the ADF.....	34
	Sending a 2-sided fax from the ADF.....	34
	Sending a fax from the scanner glass.....	35
	Faxing legal size documents from the scanner glass.....	36
	Canceling a fax in progress.....	36
	Broadcasting (black & white only).....	36
	Canceling a broadcast in progress.....	37
	Additional sending operations.....	37
	Sending faxes using multiple settings.....	37
	Electronic cover page (black & white only).....	38
	Contrast.....	39
	Changing fax resolution.....	40
	Dual access (black & white only).....	40
	Real time transmission.....	41
	Overseas mode.....	41
	Delayed fax (black & white only).....	41
	Delayed batch transmission (black & white only).....	42
	Checking and canceling waiting jobs.....	42
	Sending a fax manually.....	43
	Out of memory message.....	43

6	Receiving a fax	44
	Choose the correct Receive Mode.....	44
	Using receive modes.....	45
	Fax Only.....	45
	Fax/Tel.....	45
	Manual.....	45
	External TAD.....	45
	Receive mode settings.....	46
	Ring delay.....	46
	F/T ring time.....	46
	Easy receive.....	47
	Setting the print density.....	47
	Additional receiving operations.....	48
	Printing a reduced incoming fax.....	48
	Duplex (2-sided) printing for Fax mode.....	48
	Setting the fax receive stamp (black & white only).....	49
	Receiving a fax at the end of a conversation.....	49
	Printing a fax from the memory.....	49

7	Telephone services and external devices	50
	Telephone line services	50
	Voice Mail	50
	Distinctive ring	51
	Connecting an external TAD (telephone answering device).....	53
	Connections.....	54
	Recording an outgoing message (OGM).....	54
	Special line considerations	54
	Multi-line connections (PBX)	56
	External and extension telephones.....	56
	Operation from extension telephones.....	56
	For Fax/Tel mode only.....	56
	Connecting an external or extension telephone	57
	Using a non-Brother cordless external handset	57
	Using remote codes.....	57
8	Dialing and storing numbers	58
	How to dial	58
	Manual dialing	58
	One-touch dialing	58
	Speed-dialing.....	58
	Search	59
	LDAP Search.....	59
	Fax redial	59
	Storing numbers	60
	Storing a pause	60
	Storing one-touch dial numbers.....	60
	Storing speed-dial numbers.....	61
	Changing one-touch and speed-dial numbers.....	62
	Setting up groups for broadcasting.....	63
	Dialing access codes and credit card numbers	64
	Pause	64
	Tone or pulse (Canada only).....	64
9	Remote fax options (black & white only)	65
	Fax forwarding	65
	Paging.....	66
	Fax storage.....	66
	PC fax receive	67
	Changing remote fax options.....	68
	Turning off remote fax options	68
	Remote retrieval	69
	Setting a remote access code	69
	Using your remote access code	69
	Retrieving fax messages	70
	Changing the fax forwarding number	70
	Remote fax commands.....	71

10	Polling	72
	Polling receive	72
	Sequential polling	72
	Polled transmit (black & white only).....	73
	Setup for polled transmit.....	73

11	Printing reports	74
	Fax reports.....	74
	Transmission verification report.....	74
	Fax journal.....	74
	Reports	75
	How to print a report.....	75

Section III Copy

12	Making copies	78
	How to copy.....	78
	Entering copy mode.....	78
	Making a single copy	78
	Making multiple copies	78
	Stop copying.....	78
	Copy options (temporary settings).....	79
	Improving copy quality	79
	Enlarging or reducing the image copied	79
	Making N in 1 copies (page layout)	80
	Duplex (2-sided) copying	81
	Sorting copies using the ADF	83
	Adjusting brightness, contrast and color.....	83
	Tray selection	85
	Out of memory message	85

Section IV Walk-up printing

13	Printing photos from a digital camera	88
	Before using PictBridge	88
	PictBridge requirements	88
	Using PictBridge	88
	Setting your digital camera	88
	Printing images.....	89
	DPOF printing.....	90
	Connecting a camera as a storage device	90
	Understanding the error messages	90

14	Printing data from a USB flash memory drive	91
	Supported file formats.....	91
	Creating a PRN or PostScript® 3™ file for direct printing.....	91
	Printing data directly from the USB flash memory drive.....	92
	Understanding the error messages.....	93

Section V Software

15	Software and network features	96
	How to read HTML User's Guide.....	96
	For Windows®.....	96
	For Macintosh®.....	96

Section VI Appendixes

A	Safety and legal	98
	Choosing a location.....	98
	To use the machine safely.....	99
	Important information.....	102
	Standard telephone and FCC notices.....	102
	Industry Canada Compliance Statement (Canada only).....	105
	Disconnect device.....	105
	LAN connection.....	105
	Laser safety.....	105
	FDA regulations.....	106
	Important safety instructions.....	106
	Legal limitations for copying.....	108
	Trademarks.....	109
B	Options	110
	Options.....	110
	Optional paper tray.....	111
	Installing the optional paper tray.....	111
	Memory board.....	112
	Installing extra memory.....	113

C Troubleshooting and routine maintenance 114

Troubleshooting	114
If you are having difficulty with your machine	114
Improving the print quality	121
Setting dial tone detection	132
Telephone line interference	132
Error and maintenance messages	133
Checking if the machine has faxes in its memory	139
Transferring faxes to another fax machine	139
Transferring faxes to your PC	139
Document jams	140
Paper jams	141
Routine maintenance	152
Cleaning the outside of the machine	152
Cleaning the scanner	153
Cleaning the laser scanner windows	154
Cleaning the corona wires	158
Cleaning the drum unit	161
Replacing the consumable items	169
Replacing a toner cartridge	172
Replacing the drum unit	177
Replacing the belt unit	183
Replacing the waste toner box	188
Packing and shipping the machine	194
Repacking the machine	195
Machine information	202
Checking the serial number	202
Checking the page counters	202
Checking the remaining life of parts	203

D Menu and features 204

On-screen programming	204
Menu table	204
Memory storage	204
Menu keys	204
How to access the menu mode	205
Menu table	206
Entering text	222

E	Specifications	224
	General	224
	Print media	226
	Fax	227
	Copy	228
	Scan	229
	Print	230
	Interfaces	230
	PictBridge	231
	Direct print feature	231
	Computer requirements	232
	Consumable items	233
	Ethernet wired network	234
	Ethernet wireless network	235
	Authentication and encryption for wireless users only	236
	Wi-Fi Alliance certification	237
F	Glossary	238
G	Index	242



General

General information	2
Loading paper and documents	11
General setup	22
Security features	28

Using the documentation

Thank you for buying a Brother machine! Reading the documentation will help you make the most of your machine.

Symbols and conventions used in the documentation

The following symbols and conventions are used throughout the documentation.

Bold Bold style identifies keys on the machine control panel or computer screen.

Italics Italicized style emphasizes an important point or refers you to a related topic.

`Courier New` Courier New font identifies the messages shown on the LCD of the machine.

 Warning icons tell you what to do to avoid the risk of injury.

 Electrical Hazard icons alert you to a possible electrical shock.

 Hot Surface icons warn you not to touch machine parts that are hot.

 Caution icons tell you about procedures you must follow to prevent damaging the machine.

 Incorrect setup icons alert you to devices and operations that are not compatible with the machine.

 Note icons give useful tips.

Accessing the User's Guides

The printed User's Guide does not contain all the information about your machine. The advanced features of the Printer, Network, Scanner, and PC Fax are explained in the Software and Network User's Guides that you can find on the CD-ROM.

Viewing documentation

Viewing documentation (Windows®)

To view the documentation, from the **Start** menu, point to **Brother, MFC-9840CDW** from the program group, and then click **User's Guides in HTML format**.

If you have not installed the software, you can find the documentation by following the instructions below:

- 1 Turn on your PC.
Insert the Brother CD-ROM labeled Windows® into your CD-ROM drive.
- 2 If the language selection screen appears, click your language.
- 3 If the model name screen appears, click your model name. The CD-ROM main menu will appear.



If this window does not appear, use Windows® Explorer to find and run the start.exe program from the root directory of the Brother CD-ROM.

- 4 Click **Documentation**.

- 5 Click the documentation you want to read:
 - HTML documents (3 manuals):
HTML User's Guide for stand-alone operations, Software User's Guide and Network User's Guide.

This format is recommended for viewing on your computer.
 - PDF documents (4 manuals):
PDF User's Guide for stand-alone operations, Software User's Guide, Network User's Guide and Quick Setup Guide.

This format is recommended for printing the manuals. Click to go to the Brother Solutions Center, where you can view or download the PDF documents. (Internet access and PDF Reader software are required.)

How to find scanning instructions

There are several ways you can scan documents. You can find the instructions as follows:

Software User's Guide:

- Scanning a document using the TWAIN driver in Chapter 2
- Scanning a document using the WIA driver (For Windows® XP/Windows Vista® only) in Chapter 2
- Using ControlCenter3 in Chapter 3
- Network Scanning in Chapter 4

ScanSoft™ PaperPort™ 11SE with OCR How-to-Guides

- The complete ScanSoft™ PaperPort™ 11SE with OCR How-to-Guides can be viewed from the Help selection in the ScanSoft™ PaperPort™ 11SE with OCR application.

Viewing documentation (Macintosh®)

1 Turn on your Macintosh®. Insert the Brother CD-ROM labeled Macintosh® into your CD-ROM drive.

2 The following window will appear.

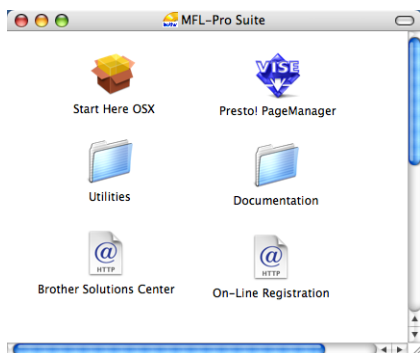

3 Double-click the **Documentation** icon.

4 If the language selection screen appears, double-click your language.

5 Double-click the top page file to view the User's Guide, Software User's Guide and Network User's Guide in HTML format.

6 Click the documentation you want to read.

- User's Guide
- Software User's Guide
- Network User's Guide

Note

The documents are also available in PDF format (4 manuals):

PDF User's Guide for stand-alone operations, Software User's Guide, Network User's Guide and Quick Setup Guide.

The PDF format is recommended for printing the manuals.

Double-click **Brother Solutions Center** icon to go to the Brother Solutions Center, where you can view or download the PDF documents. (Internet access and PDF Reader software are required.)

How to find scanning instructions

There are several ways you can scan documents. You can find the instructions as follows:

Software User's Guide:

- Scanning in Chapter 9
- Using ControlCenter2 in Chapter 10
- Network Scanning in Chapter 11

Presto!® PageManager® User's Guide:

- Instructions for scanning directly from Presto!® PageManager® The complete Presto!® PageManager® User's Guide can be viewed from the Help selection in the Presto!® PageManager® application.

Accessing Brother support (for Windows®)

You can find all the contacts you will need, such as Web support (Brother Solutions Center), Customer Service and Brother Authorized Service Centers on page ii and on the Brother CD-ROM.

- Click **Brother Support** on the main menu. The following screen will appear:

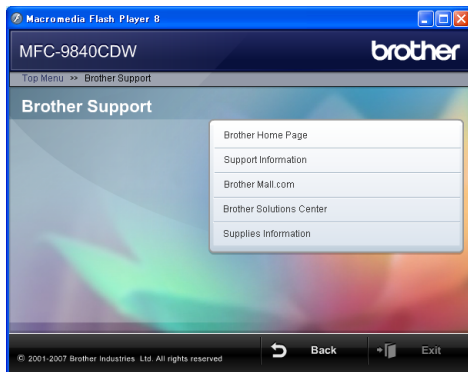

- To access our web site (<http://www.brother.com>) click **Brother Home Page**.
- To view all Brother Numbers, including Customer Service numbers for the USA and Canada, click **Support Information**.
- To access the USA Brother online shopping mall (<http://www.brothermall.com>) for additional product and service information, click **Brother Mall.com**.
- For the latest news and product support information (<http://solutions.brother.com/>), click **Brother Solutions Center**.
- To visit our web site for original/genuine Brother supplies (<http://www.brother.com/original>), click **Supplies Information**.

To return to the main page, click **Back**.

Or, if you have finished, click **Exit**.

Control panel overview

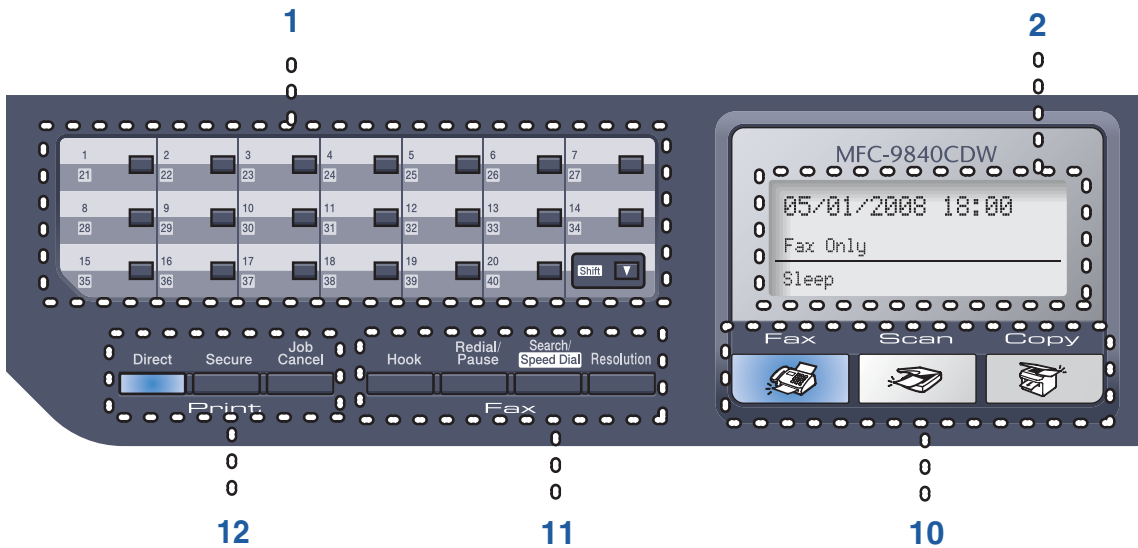

1 One-Touch keys

These 20 keys give you instant access to 40 previously stored numbers.

Shift

Lets you access One-Touch numbers 21 to 40 when held down.

2 LCD

Displays messages to help you set up and use your machine.

3 Status LED

The LED will flash and change color depending on the machine status.

4 Menu keys:

Menu

Lets you access the Menu to program your settings in this machine.

Clear/Back

Deletes entered data or lets you cancel the current setting.

OK

Lets you store your settings in the machine.

Volume keys

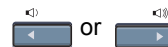

or

Press to scroll backwards or forwards through menu selections. Press to change the volume when in fax or standby mode.

▲ or ▼

Press to scroll through the menus and options.

5 Dial pad

Use these keys to dial telephone and fax numbers and as a keyboard for entering information into the machine.

(Canada only) The # key temporarily switches the dialing mode from Pulse to Tone during a telephone call.

6 Stop/Exit

Stops an operation or exits from a menu.

7 Start:

Color

Lets you start sending faxes or making copies in full color.

Black

Lets you start sending faxes or making copies in black & white.

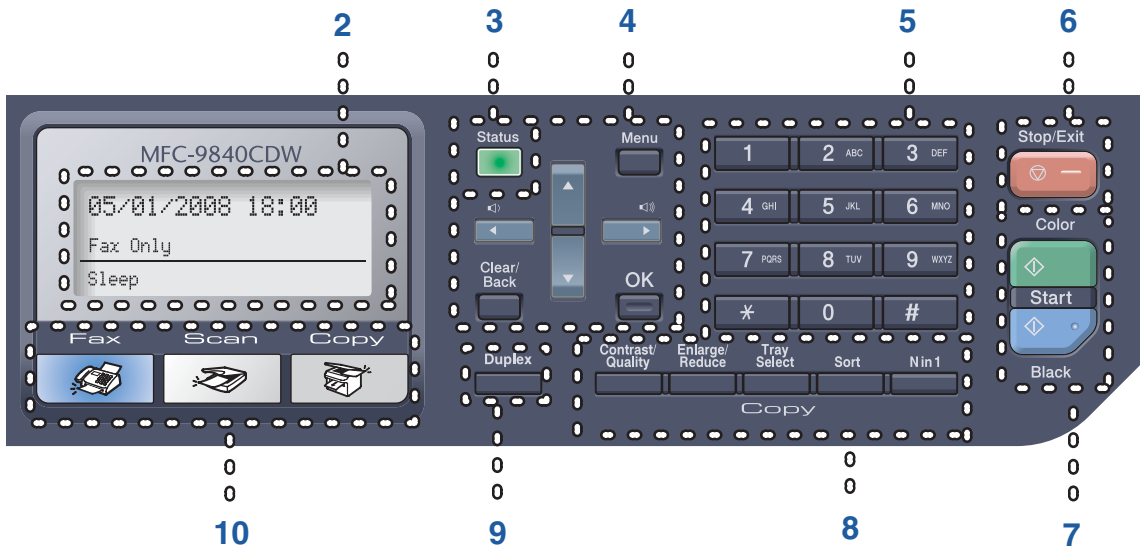

8 Copy keys:

Contrast/Quality

Lets you change the quality or contrast for the next copy.

Enlarge/Reduce

Reduces or enlarges copies.

Tray Select

Lets you change which tray will be used for the next copy.

Sort

Sorts multiple copies using the ADF.

N in 1

You can choose N in 1 copy to 2 or 4 pages onto one page.

9 Duplex

You can choose Duplex to copy on both sides of paper.

10 Mode keys:



Fax

Puts the machine in Fax mode.



Scan

Puts the machine in Scan mode. (For details about scanning, see the *Software User's Guide on the CD-ROM*.)



Copy

Puts the machine in Copy mode.

11 Fax and telephone keys:

Hook

Press before dialing if you want to make sure a fax machine will answer, and then press **Black Start** or **Color Start**. Also, press this key after you pick up the handset of an external telephone during the F/T ring (fast double-rings).

Redial/Pause

Redials the last number called. It also inserts a pause when programming quick dial numbers.

Search/Speed Dial

Lets you look up numbers stored in the quick-dial memory and LDAP server.

You can search the stored number by alphabetically

It also lets you look up the stored number in Speed-Dial numbers by pressing **Shift** and **Search/Speed Dial** simultaneously and then the three-digit number.

Resolution

Sets the resolution when sending a fax.

12 Print keys

Direct

Lets you print data from a USB flash memory drive that you can connect directly to the machine. You can also print images directly from your PictBridge compatible camera.

Secure

When using Secure Function Lock, you can switch restricted users by holding down **Shift** as you press the **Secure** key. (See *Secure Function Lock* on page 29.)

You can print data saved in memory when you enter your four-digit password. (For details about using the Secure key, see the *Software User's Guide on the CD-ROM*.)

Job Cancel

Cancels a programmed print job and clears print data in machine's memory.





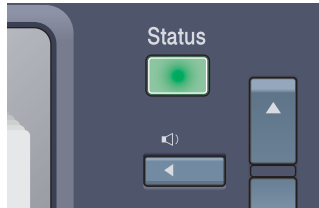

Status LED indications

The **Status** LED (light emitting diode) will flash and change color depending on the machine's status.



The LED indications shown in the table below are used in the illustrations in this chapter.

LED	LED Status
○	LED is off.
<div style="display: flex; justify-content: space-around; align-items: center;"> <div style="text-align: center;">● Green</div> <div style="text-align: center;">● Yellow</div> <div style="text-align: center;">● Red</div> </div>	LED is on.
<div style="display: flex; justify-content: space-around; align-items: center;"> <div style="text-align: center;">⊙ Green</div> <div style="text-align: center;">⊙ Yellow</div> <div style="text-align: center;">⊙ Red</div> </div>	LED is blinking.

LED	Machine Status	Description
	Sleep Mode	The power switch is off or the machine is in Sleep mode.
 Green	Warming Up	The machine is warming up for printing.
 Green	Ready	The machine is ready to print.
 Yellow	Receiving Data	The machine is either receiving data from the computer, processing data in memory, or printing data.
 Yellow	Data Remaining in Memory	Print data remains in the machine memory.
 Red	Service error	Follow the steps below. <ol style="list-style-type: none"> 1. Turn off the power switch. 2. Wait a few seconds, and then turn it back on and try to print again. If you cannot clear the error and you see the same service call indication after turning the machine back on, please call Brother Customer Service. (See <i>Brother numbers</i> on page i.)
 Red	Cover open	The front cover or fuser cover is open. Close the cover.
	Toner Life End	Replace the toner cartridge with a new one.
	Paper error	Put paper in the tray or clear the paper jam. Check the LCD message.
	Scan lock	Check that the scanner lock lever is released.
	Others	Check the LCD message.
	Out of memory	Memory is full.

 **Note**

When the power switch is off or the machine is in Sleep mode, the LED is off.

Acceptable paper and other media

Recommended paper

To get the best print quality, we suggest using the following paper.

Paper Type	Item
Plain paper	Xerox 4200DP 20 lb
	Hammermill Laser Paper (24 lb=90 g/m ²)
	(Xerox Premier 80 g/m ²)
	(Xerox Business 80 g/m ²)
Recycled paper	(Xerox Recycled Supreme)
Labels	Avery laser label #5160 (Avery laser label L7163)
Envelope	Columbian #138 (COM10)

Print quality may vary according to the type of paper you are using.

You can use the following types of media: plain paper, labels or envelopes.

For best results, follow the steps below:

- Your supplier paper made for plain paper copying.
- Use paper that is 20 to 24 lb (75 to 90 g/m²).
- Use labels which are designed for use in laser printers.
- Avoid touching the printed surface of the paper immediately after printing.
- Use long grain paper with a neutral Ph value, and a moisture content of approx 5%.

! CAUTION

DO NOT load envelopes, labels or thick paper (more than 28 lb or 105 g/m²) into the paper tray or optional lower tray. It may cause paper jams.

Type and size of paper

The machine loads paper from the installed standard paper tray, multi-purpose tray, or optional lower tray.

Standard paper tray

Since the standard paper tray is a universal type, you can use any of the paper sizes (one paper type and size at a time) listed in the table in *Paper capacity of the paper trays* on page 12. The standard paper tray can hold up to 250 sheets of Letter/A4, legal and folio size paper (20 lb or 80 g/m²). Paper can be loaded up to the maximum paper mark on the sliding paper width guide.

Multi-purpose tray (MP tray)

The MP tray can hold up to 50 sheets of paper (20 lb or 80 g/m²) or up to 3 envelopes. Paper can be loaded up to the maximum paper mark on the sliding paper width guide.

Optional lower tray (LT-100CL)

The optional lower tray can hold up to 500 sheets of Letter/A4, legal and folio size paper (20 lb or 80 g/m²). Paper can be loaded up to the top line of the maximum paper mark on the sliding paper width guide.

The names for the paper trays in the printer driver and this Guide are as follows:

Tray and optional unit	Name
Standard paper tray	Tray 1
Optional lower tray	Tray 2
Multi-purpose tray	MP tray

Paper capacity of the paper trays

	Paper size	Paper types	No. of sheets
Paper Tray (Tray #1)	A4, Letter, Legal, Executive, A5, A6, B5, B6 and Folio ¹	Plain paper, Thin paper and Recycled paper	up to 250 [20 lb (80 g/m ²)]
Multi-purpose tray (MP tray)	Width: 2.75 to 8.5 in. (69.9 to 215.9 mm) Length: 4.57 to 16.0 in. (116.0 to 406.4 mm)	Plain paper, Thin paper, Thick paper, Recycled paper, Bond paper, Envelope and Labels	up to 50 (plain paper) [20 lb (80 g/m ²)] up to 3 (envelopes)
Paper Tray (Tray #2)	A4, Letter, Legal, Executive, A5, B5, B6 and Folio ¹	Plain paper, Thin paper and Recycled paper	up to 500 [20 lb (80 g/m ²)]

¹ Folio size is 8 in. × 13 in.

Recommended paper specifications

The following paper specifications are suitable for this machine.

Basis weight (lb (g/m ²))	20-24 (75-90)
Thickness (μm)	80-110
Roughness (sec.)	Higher than 20
Stiffness (cm ³ /100)	90-150
Grain direction	Long grain
Volume resistivity (ohm)	10e ⁹ -10e ¹¹
Surface resistivity (ohm-cm)	10e ⁹ -10e ¹²
Filler	CaCO ₃ (Neutral)
Ash content (wt%)	Below 23
Brightness (%)	Higher than 80
Opacity (%)	Higher than 85

Handling and using special paper

The machine is designed to work well with most types of xerographic and bond paper. However, some paper variables may have an effect on print quality or handling reliability. Always test samples of paper before purchasing to ensure desirable performance. Store paper in its original packaging and keep it sealed. Keep the paper flat and away from moisture, direct sunlight and heat.

Some important guidelines when selecting paper are:

- Your supplier should be informed that the paper or envelopes will be used in a color laser machine.
- Preprinted paper must use inks that can withstand the temperature of the machine's fusing process (392 degrees Fahrenheit or 200 degrees centigrade for a period of 0.1 seconds).
- If you have selected a cotton bond paper, paper having a rough surface, such as cockle or laid finished paper or paper that is wrinkled or puckered, the paper may exhibit degraded performance.

Types of paper to avoid

! CAUTION

Some types of paper may not perform well or may cause damage to your machine.

DO NOT use paper:

- that is highly textured
- that is extremely smooth or shiny
- that is curled or warped

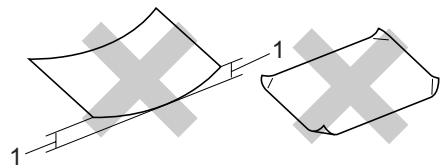

1 0.08 in. (2 mm) or greater

- that is coated or has a chemical finish
- that is damaged, creased or folded
- that exceeds the recommended weight specification in this guide
- with tabs and staples
- with letterheads using low temperature dyes or thermography
- that is multipart or carbonless
- that is designed for inkjet printing

If you use any of the types of paper listed above, they may damage your machine. This damage is not covered under any Brother warranty or service agreement.

Envelopes

Most envelopes will be suitable for your machine. However, some envelopes will have feed and print-quality problems because of the way they have been made. A suitable envelope should have edges with straight, well-creased folds and the leading edge should not be thicker than two pieces of paper. The envelope should lie flat and not be of baggy or flimsy construction. You should buy quality envelopes from a supplier who understands that you will be using the envelopes in a laser machine.

Envelopes can only be fed from MP tray.

Before you put envelopes in the tray, check the following:

- Envelopes should have a lengthwise sealing flap.
- The sealing flaps should be folded crisply and correctly (irregularly cut or folded envelopes may cause paper jams).
- Envelopes should consist of two layers of paper in the area circled in figure below.

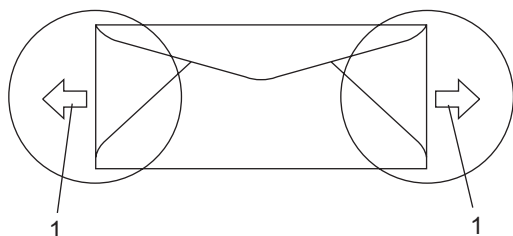

1 Feeding direction



Note

- Before you print envelopes, you must 'fan' the stack to avoid paper jams and misfeeds.
- Before you print a lot of envelopes, test one to make sure that the print results are what you want.
- Envelope joints that are sealed by the manufacturer should be secure.
- DO NOT put different types of paper in the paper tray at the same time because it may cause paper jams or misfeeds.
- For proper printing, you must choose the same paper size from your software application as the paper in the tray.
- We recommend that you do not print within 0.6 in. (15 mm) of the edges of envelopes.
- See *Acceptable paper and other media* on page 11.

Types of envelopes to avoid

! CAUTION

DO NOT use envelopes:

- that are damaged, curled, wrinkled or an unusual shape
- that are extremely shiny or textured
- with clasps, staples, snaps or tie strings
- with self-adhesive closures
- that are of a baggy construction
- that are not sharply creased
- that are embossed (have raised writing on them)
- that were previously printed by a laser machine
- that are pre-printed on the inside
- that cannot be arranged neatly when stacked
- that are made of paper that weighs more than the paper weight specifications for the machine
- with edges that are not straight or consistently square
- with windows, holes, cut-outs or perforations
- with glue on surface as shown in figure below

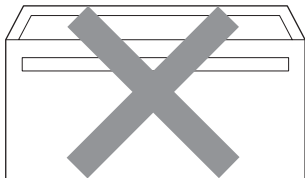

- with double flaps as shown in figure below

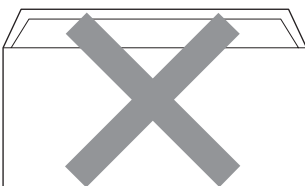

- with sealing flaps that have not been folded at purchase
- with sealing flaps as shown in figure below

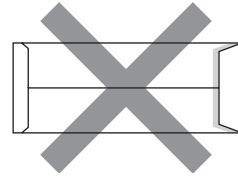

- with each side folded as shown in figure below

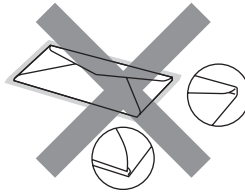

If you use any of the types of envelopes listed above, they may damage your machine. This damage is not covered under any Brother warranty or service agreement.

Occasionally you may experience paper feed problems caused by the thickness, size and flap shape of the envelopes you are using.

Labels

The machine will print on most types of labels designed for use with a laser machine. Labels should have an adhesive that is acrylic-based since this material is more stable at the high temperatures in the fuser unit. Adhesives should not come in contact with any part of the machine, because the label stock may stick to the belt unit or rollers and cause jams and print quality problems. No adhesive should be exposed between the labels. Labels should be arranged so that they cover the entire length and width of the sheet. Using labels with spaces may result in labels peeling off and causing serious jams or print problems.

All labels used in this machine must be able to withstand a temperature of 392 degrees Fahrenheit (200 degrees centigrade) for a period of 0.1 seconds.

Label sheets should not exceed the paper weight specifications described in this User's Guide. Labels exceeding this specification may not feed or print properly and may cause damage to your machine.

Labels can be fed from the MP tray only.

Types of labels to avoid

DO NOT use labels that are damaged, curled, wrinkled or an unusual shape.



! CAUTION

Avoid feeding labels with the carrier sheet exposed because your machine will be damaged.

Unprintable area

Unprintable area for copies

The printable area of your machine begins at approximately 0.16 in. (4 mm) from the top and bottom and 0.12 in. (3 mm) from both sides of the paper.

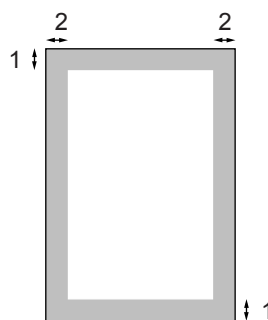

1 0.16 in. (4 mm)

2 0.12 in. (3 mm)



Note

This unprintable area shown above is for a single copy or a 1 in 1 copy using Letter size paper. The unprintable area changes with the paper size.

Unprintable area when printing from a computer

When using the default driver the printable area is smaller than the paper size, as shown below.

Portrait

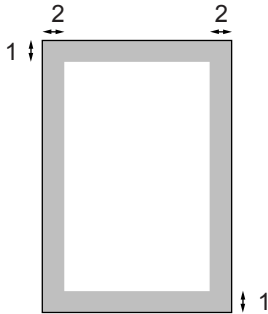

1 0.16 in. (4.23 mm)

2 0.16 in. (4.23 mm)

Landscape

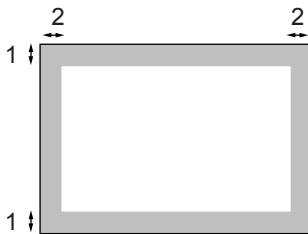

1 0.16 in. (4.23 mm)

2 0.16 in. (4.23 mm)



Note

The unprintable area shown above is for Letter size paper. The unprintable area changes with the paper size.

Loading paper and envelopes

The machine can feed paper from the standard paper tray, optional lower tray or multi-purpose tray.

When printing on plain paper 16 to 28 lb (60 to 105 g/m²) use the paper tray.

For printing on other types of media use the MP tray (multi-purpose tray).

When you put paper into the paper tray, note the following:

- If your application software supports paper size selection on the print menu, you can select it through the software. If your application software does not support it, you can set the paper size in the printer driver or by using the control panel buttons.
- Before using paper that has holes in it, such as organizer sheets, you must 'fan' the stack to avoid paper jams and misfeeds.



Loading plain paper in the paper tray

- 1 Unfold the output paper tray support flap (1).



- 2 Pull the paper tray completely out of the machine.

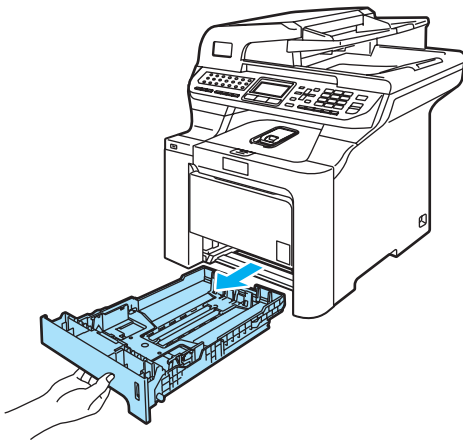

- 3 While pressing the green paper-guide release lever (1), slide the paper guides to fit the paper size. Make sure that the guides are firmly in the slots.

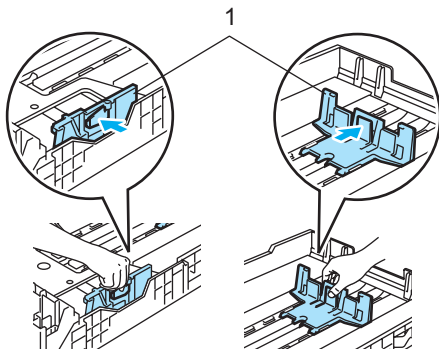

- 4 Fan the stack of paper well to avoid paper feeding problems.

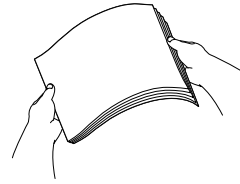

- 5 Put the paper into the paper tray with the top edge of the paper in first and the print side face down. Make sure that the paper is flat in the tray and below the maximum paper mark (1).

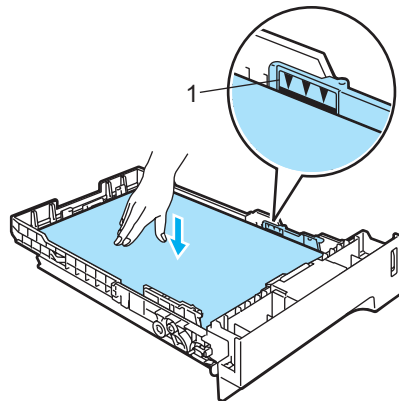

- 6 Push the paper tray firmly back into the machine.

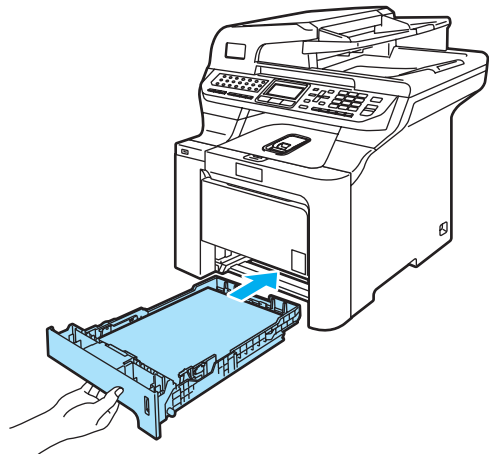

Loading envelopes or other media in the multi-purpose tray (MP tray)

Use the MP tray when printing envelopes, labels, and thick paper.

Before loading, press the corners and sides of the envelopes to make them as flat as possible.

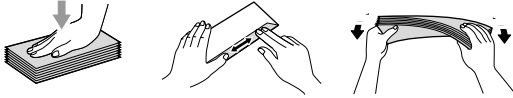

- 1 Unfold the output paper tray support flap (1).



- 2 Open the MP tray and lower it gently.

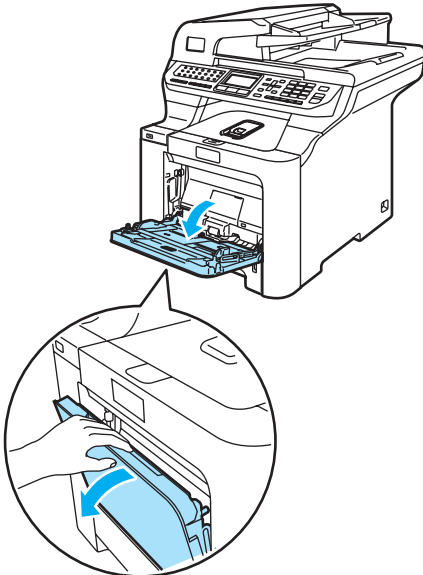

- 3 Pull out the MP tray support flap (1).



- 4 Put the envelopes (up to 3) or media in the MP tray with the top edge first and the print side face up.

Loading documents

You can send a fax, make copies, and scan from the ADF (automatic document feeder) and from the scanner glass.

Using the ADF (automatic document feeder)

The ADF can hold up to 50 pages and feeds each sheet individually. Use standard 20 lb (80 g/m²) paper and always fan the pages before putting them in the ADF.

! CAUTION

DO NOT leave thick documents on the scanner glass. If you do this, the ADF may jam.

DO NOT use paper that is curled, wrinkled, folded, ripped, stapled, paper-clipped, pasted or taped.

DO NOT use cardboard, newspaper or fabric.

- Make sure documents written with ink are completely dry.

Single-sided document

Documents to be faxed must be from 5.8 to 8.5 inches (147.3 to 215.9 mm) wide and from 5.8 to 14 inches (147.3 to 356 mm) long, and of a standard weight [20 lb (80 g/m²)].

2-sided document

When you load a 2-sided document, the document to be faxed must be from 5.8 to 8.5 inches (147.3 to 215.9 mm) wide and from 5.8 to 11.7 inches (147.3 to 297 mm) long, and of a standard weight [20 lb (80 g/m²)].

- 1 Unfold the ADF document output support flap (1) and the ADF support flap (2).

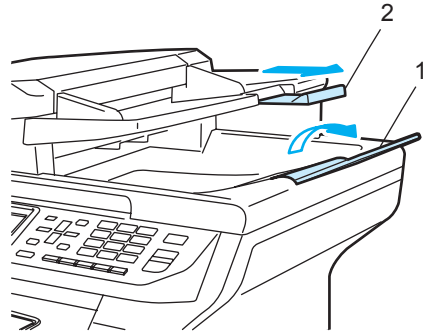

- 2 Fan the pages well.
- 3 Place your document, face up top edge first, in the ADF until you feel it touch the feed roller. The LCD will show ADF Ready.
- 4 Adjust the paper guides to fit the width of your document.

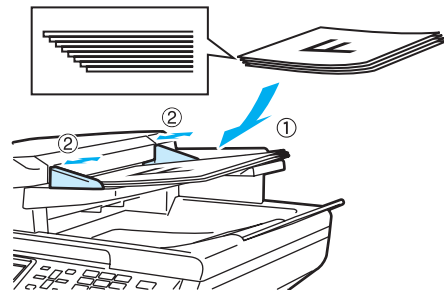

! CAUTION

To avoid damaging your machine while using the ADF, DO NOT pull on the document while it is feeding.

To scan non-standard documents see *Using the scanner glass* on page 21.

Using the scanner glass

You can use the scanner glass to fax, scan, or copy the pages of a book or one page at a time. Documents can be up to 8.5 inches wide and up to 14 inches long (215.9 mm wide to 355.6 mm long).

To use the scanner glass, the ADF must be empty.

- 1 Lift the document cover.
- 2 Using the document guidelines on the left, center the document face down on the scanner glass.

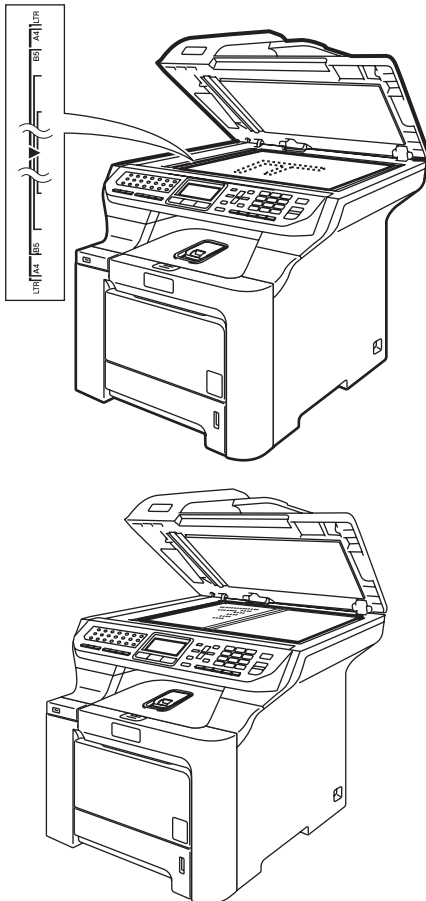

- 3 Close the document cover.

! CAUTION

If the document is a book or is thick, DO NOT slam the cover or press on it.

2

3

General setup

Mode timer

The machine has three mode keys on the control panel: **Fax**, **Scan**, and **Copy**.

You can set how much time the machine takes after the last Copy or Scan operation to return to Fax mode. If you choose **Off**, the machine will stay in the mode you used last.

Also, this setting sets the time the machine will change from individual user to public user when using Secure Function Lock. (See *Switching Users* on page 32.)



- 1 Press **Menu**, **1**, **1**

```
11.Mode Timer
▲ 2 Mins
  5 Mins
▼ Off
Select ▲▼ or OK
```

- 2 Press **▲** or **▼** to choose 0 Sec, 30 Secs, 1 Min, 2 Mins, 5 Mins or Off. Press **OK**.
- 3 Press **Stop/Exit**.

Paper settings

Paper type

Set up the machine for the type of paper you are using. This will give you the best print quality.

- 1 Do one of the following:
 - To set the paper type for the MP Tray press **Menu**, **1**, **2**, **1**.
 - To set the paper type for Tray#1 press **Menu**, **1**, **2**, **2**.
 - To set the paper type for Tray#2 press **Menu**, **1**, **2**, **3** if you installed the optional tray.

```
12.Paper Type
 1.MP Tray
▲ Plain
▼ Thick
Select ▲▼ or OK
```

- 2 Press **▲** or **▼** to choose Thin, Plain or Recycled Paper for Tray#1 and Tray#2. Choose Thin, Plain, Thick, Thicker or Recycled Paper for MP Tray. Press **OK**.
- 3 Press **Stop/Exit**.

Paper size

You can use nine sizes of paper for printing copies: A4, Letter, Legal, Executive, A5, A6, B5, B6 and Folio, and four sizes for printing faxes: A4, Letter, Legal or Folio (8"×13").

When you change the size of paper in the tray, you will also need to change the setting for paper size at the same time so your machine can fit the document or an incoming fax on the page.

- 1 Do one of the following:
 - To set the paper size for the MP Tray press **Menu, 1, 3, 1**.
 - To set the paper size for Tray#1 press **Menu, 1, 3, 2**.
 - To set the paper size for Tray#2 press **Menu, 1, 3, 3** if you installed the optional tray.

```

13.Paper Size
  1.MP Tray
  ▲ Letter
  ▼ Legal
  Select ▲▼ or OK
  
```

- 2 Press **▲** or **▼** to choose A4, Letter, Legal, Executive, A5, A6, B5, B6, Folio or Any. Press **OK**.
- 3 Press **Stop/Exit**.



Note

- Any (size) appears only when you choose the MP tray (**Menu, 1, 3, 1**).
- If you choose Any for the MP Tray Paper Size: You must choose MP Only for the Tray Use setting. You cannot use the Any Paper Size selection for the MP tray when making N in 1 copies. You must choose one of the other available Paper Size selections for the MP tray.
- A6 size is not available for the optional Tray #2.

Tray use in copy mode

You can change the priority tray that the machine will use for printing copies.

When you choose Tray#1 Only, MP Only or Tray#2 Only¹, the machine pulls the paper only from that tray. If the selected tray is out of paper, No Paper will appear on the LCD. Insert the paper in the empty tray.

To change the tray setting follow the instructions below:

- 1 Press **Menu, 1, 7, 1**.

```

17.Tray Use
  1.Copy
  ▲ MP>T1
  ▼ T1>MP
  Select ▲▼ or OK
  
```

- 2 Press **▲** or **▼** to choose Tray#1 Only, Tray#2 Only¹, MP Only, MP>T1>T2¹ or T1>T2¹>MP. Press **OK**.

¹ Tray#2 Only or T2 appears only if the optional tray is installed.

- 3 Press **Stop/Exit**.



Note

- When loading the documents in the ADF and MP>T1>T2 or T1>T2>MP is selected, the machine looks for the tray with the most suitable paper and pulls paper from that tray. If no tray has suitable paper, the machine pulls paper from the higher priority tray.
- When using the scanner glass, your document is copied from the higher priority tray even if more suitable paper is in another paper tray.

Tray use in fax mode

You can change the default tray that the machine will use for printing received faxes.

When you choose **Tray#1 Only**, **MP Only** or **Tray#2 Only**¹, the machine pulls the paper only from that tray. If the selected tray is out of paper, **No Paper** will appear on the LCD. Insert the paper in the empty tray.

When you choose **T1>T2**¹>**MP**, the machine pulls paper from **Tray #1** until it is empty, then from **Tray #2**, and then from the **MP** tray.

When you choose **MP>T1>T2**¹, the machine pulls paper from the **MP** tray until it is empty, then from **Tray #1**, and then from **Tray #2**.



Note

- You can use four sizes of paper for printing faxes: A4, Letter, Legal or Folio. When a suitable size is not in any of the trays received faxes will be stored in the machine's memory and **Check Paper Size** will appear on the LCD. (For details, see *Error and maintenance messages* on page 133.)
- If the tray is out of paper and received faxes are in the machine's memory, **No Paper** will appear on the LCD. Insert paper in the empty tray.

- 1 Press **Menu**, **1**, **7**, **2**.

```
17.Tray Use
 2.Fax
▲  MP>T1
▼  T1>MP
Select ▲▼ or OK
```

- 2 Press **▲** or **▼** to choose **Tray#1 Only**, **Tray#2 Only**, **MP Only**, **MP>T1>T2**¹ or **T1>T2**¹>**MP**. Press **OK**.

¹ **Tray#2 Only** or **T2** appears only if the optional tray is installed.

- 3 Press **Stop/Exit**.

Tray use in print mode

You can change the default tray the machine will use for printing from your computer.

- 1 Press **Menu**, **1**, **7**, **3**.

```
17.Tray Use
 3.Print
▲  MP>T1
▼  T1>MP
Select ▲▼ or OK
```

- 2 Press **▲** or **▼** to choose **Tray#1 Only**, **Tray#2 Only**¹, **MP Only**, **MP>T1>T2**¹ or **T1>T2**¹>**MP**. Press **OK**.

¹ **Tray#2 Only** or **T2** appears only if the optional tray is installed.

- 3 Press **Stop/Exit**.



Note



- The setting in the printer driver will take priority over the setting made on the control panel.
- If the control panel is set to **Tray#1 Only**, **MP Only** or **Tray#2 Only**¹ and you choose **Auto Select** in the printer driver, the machine pulls the paper from that tray.

¹ **Tray#2 Only** appears only if the optional tray is installed.

Volume settings

Ring volume

You can choose a ring volume level from a range of settings, from **High** to **Off**.

While in Fax mode press  or  to adjust the volume level. The LCD shows the current setting, and each key press will change the volume to the next level. The machine will keep the new setting until you change it.

You can also change the ring volume through the menu:

- 1 Press **Menu, 1, 4, 1**.

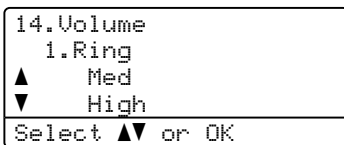

- 2 Press **▲** or **▼** to choose **Off**, **Low**, **Med** or **High**. Press **OK**.
- 3 Press **Stop/Exit**.

Beeper volume

When the beeper is on, the machine will beep when you press a key, make a mistake, or after you send or receive a fax. You can choose a range of volume levels, from **High** to **Off**.

- 1 Press **Menu, 1, 4, 2**.

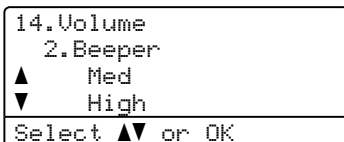



- 2 Press **▲** or **▼** to choose **Off**, **Low**, **Med** or **High**. Press **OK**.
- 3 Press **Stop/Exit**.

Speaker volume

You can choose a range of speaker volume levels, from **High** to **Off**.

You can adjust the speaker volume with the control panel keys.

- 1 Press  (**Fax**).
- 2 Press **Hook**.
- 3 Press  or . This setting will stay until you change it again.
- 4 Press **Hook**.

You can also change the speaker volume through the menu:

- 1 Press **Menu, 1, 4, 3**.

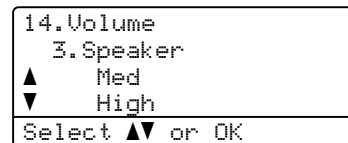

- 2 Press **▲** or **▼** to choose **Off**, **Low**, **Med** or **High**. Press **OK**.
- 3 Press **Stop/Exit**.

Automatic daylight savings time

You can set the machine to change automatically for Daylight Savings Time. It will set itself forward one hour in the Spring, and back one hour in the Fall.

- 1 Press **Menu 1, 5**.

```
15.Auto Daylight
▲      On
▼      Off
Select ▲▼ or OK
```

- 2 Press ▲ or ▼ to choose On (or Off). Press **OK**.
- 3 Press **Stop/Exit**.

Ecology features

Toner save

You can save toner using this feature. When you set toner save to On, print appears lighter. The default setting is Off.

- 1 Press **Menu, 1, 6, 1**.

```
16.Ecology
 1.Toner Save
▲      On
▼      Off
Select ▲▼ or OK
```

- 2 Press ▲ or ▼ to choose On (or Off). Press **OK**.
- 3 Press **Stop/Exit**.



Note

We DO NOT recommend Toner Save for printing Photo or Gray Scale images.

Sleep time

Setting the sleep time reduces power consumption by turning off the fuser while the machine is idle.

You can choose how long the machine must be idle (from 000 to 240 minutes) before it goes into sleep mode. When the machine receives a fax, computer data, or makes a copy, the timer will be reset. The default setting is 005 minutes.

While the machine is in sleep mode the LCD will display *Sleep*. When printing or copying in sleep mode, there will be a short delay while the fuser warms up.

- 1 Press **Menu 1, 6, 2**.

```
16.Ecology
 2.Sleep Time
      005Min
Enter & OK Key
```

- 2 Enter the length of time the machine is idle before entering sleep mode (000 to 240). Press **OK**.
- 3 Press **Stop/Exit**.

Turning off the scanner lamp

The scanner lamp stays on for 30 minutes before automatically switching off to preserve the life of the lamp and reduce power consumption.

To turn the scanner lamp off manually press the ◀ and ▶ keys simultaneously. The scanner lamp will remain turned off until the next time you use the scanning feature.



Note

Turning the lamp off regularly will reduce the lamp's life.

LCD contrast

You can change the contrast to make the LCD look lighter or darker.

- 1 Press **Menu**, **1**, **8**.

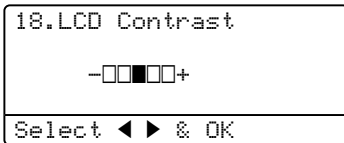

- 2 Press **▶** to make the LCD darker. Or, press **◀** to make the LCD lighter. Press **OK**.
- 3 Press **Stop/Exit**.

Dial Prefix

The dial prefix setting will automatically dial a predefined number before every fax number you dial. For example: If your telephone system requires a 9 to dial an outside number use this setting to automatically dial 9 for every fax you send.

- 1 (USA) Press **Menu**, **0**, **5**.
(Canada) Press **Menu**, **0**, **6**.
- 2 Press **▲** or **▼** to choose **On** or **Off**. Press **OK**.
 - If you chose **On**, go to 3.
 - If you chose **Off**, go to 5.
- 3 Press **1** or **2** to choose **1.Change** or **2.Exit**.
 - If you chose **1.Change**, go to 4.
 - If you chose **2.Exit**, go to 5.
- 4 Enter the prefix number (up to 5 digits) on the dial pad. Press **OK**.



Note

- You can use the numbers 0 to 9, #, * and !. (Press **Hook** to display "!".)
You cannot use ! with any other numbers or characters.
- (Canada only) If the pulse dialing mode is on, # and * are not available to use.

- 5 Press **Stop/Exit**.

4

Security features

Security

You can set up your machine with multiple levels of security using Setting Lock and Secure Function Lock. You will not be able to continue to schedule Delayed Faxes. However, any prescheduled Delayed Faxes will be sent even if you turn on Secure Function Lock, so they won't be lost.

Setting lock

Setting Lock lets you set a password to stop other people from accidentally changing your machine settings.

Make a careful note of your password. If you forget it, please call Brother Customer Service.

While Setting Lock is **On**, you cannot change the following settings without a password:

- Date/Time
- Station ID
- Quick-Dial settings
- Mode Timer
- Paper Type
- Paper Size
- Volume
- Auto Daylight
- Ecology
- Tray Use
- LCD Contrast
- Setting Lock
- Secure Function Lock

Setting up the password

- 1 Press **Menu, 1, 9, 1**.

```
19.Security
 1.Setting Lock

New Passwd:XXXX
Enter & OK Key
```

- 2 Enter a four-digit number for the password using numbers 0-9, * or #. Press **OK**.
- 3 Re-enter your password when the LCD shows *Verify:.* Press **OK**.
- 4 Press **Stop/Exit**.

Changing your setting lock password

- 1 Press **Menu, 1, 9, 1**.

```
19.Security
 1.Setting Lock
▲ On
▼ Set Password
Select ▲▼ or OK
```

- 2 Press **▲** or **▼** to choose *Set Password*. Press **OK**.
- 3 Enter your four-digit password. Press **OK**.
- 4 Enter a four-digit number for the new password. Press **OK**.
- 5 Re-enter your new password when the LCD shows *Verify:.* Press **OK**.
- 6 Press **Stop/Exit**.

Turning setting lock on/off

If you enter the wrong password when following the instructions below, the LCD will show `Wrong Password`. Re-enter the correct password.

Turning setting lock on

- 1 Press **Menu, 1, 9, 1**.

```
19.Security
 1.Setting Lock
  ▲   On
  ▼   Set Password
Select ▲▼ or OK
```

- 2 Press **▲** or **▼** to choose `On`. Press **OK**.
- 3 Enter your four-digit password. Press **OK**.
- 4 Press **Stop/Exit**.

Turning setting lock off

- 1 Press **Menu, 1, 9, 1**.

```
19.Security
 1.Setting Lock
 Password:XXXX
Enter & OK Key
```

- 2 Enter your four-digit password. Press **OK** twice.
- 3 Press **Stop/Exit**.

Secure Function Lock

Secure Function Lock lets you restrict Public access to certain machine functions (Fax Tx, Fax Rx, Copy, Scan and Print ¹).

This feature also prevents users from changing the Default settings of the machine by limiting access to the Menu settings.

Disabling at least one function is required to turn on Secure Function Lock for the Public user.

Access to restricted operations can be enabled by creating a restricted user. Restricted users must enter a user password to use the machine.

Make a careful note of your password. If you forget it, please call Brother Customer Service.

¹ Print includes PC-Fax Send as well as all print jobs.



Note

- You can set up to 25 individual users and one Public user.
- When you set up a Public user, you can restrict one or more of the machine's functions to all users who do not have a password.
- Only administrators can set limitations and make changes for each user.
- When Print is disabled, PC print jobs will be lost without notification.
- When Secure Function Lock is on, you can only use `21.Contrast`, `26.Polled TX` or `27.Coverpg Setup` in the Fax menu.

If Fax Tx is disabled, you cannot use any function in the Fax menu.

- Polling Receive is enabled only when the both Fax Tx and Fax Rx are enabled.

Setting the password for the administrator

The password you set in these steps is for the administrator. This password is used to set up users and to turn Secure Function Lock on or off. (See *Setting up restricted users* on page 31 and *Turning Secure Function Lock on* on page 31.)

- 1 Press **Menu, 1, 9, 2**.

```
19.Security
 2.Function Lock

New Passwd:XXXX
Enter & OK Key
```

- 2 Enter a four-digit number for the password using numbers 0-9, * or #. Press **OK**.
- 3 Re-enter the password when the LCD shows *Verify:.* Press **OK**.
- 4 Press **Stop/Exit**.

Setting up the Public user

You can set up the Public user. Public users do not need to enter a password.



Note

You must disable at least one function to turn on Secure Function Lock for Public user.

- 1 Press **Menu, 1, 9, 2**.

```
19.Security
 2.Function Lock
▲ Lock Off-On
▼ Set Password
Select ▲▼ or OK
```

- 2 Press **▲** or **▼** to select *Setup User*. Press **OK**.
- 3 Enter the administrator password. Press **OK**.

```
19.Security
  Setup User
▲ Public
▼ User01
Select ▲▼ or OK
```

- 4 Press **▲** or **▼** to select *Public*. Press **OK**.
- 5 Press **▲** or **▼** to select *Enable* or *Disable* for Fax Tx. Press **OK**. After you have set Fax Tx, repeat this step for Fax Rx, Copy(Color), Copy(B&W), Scan and Print. Press **OK**.



Note

You can set PC print for only the Public user. When Print is disabled for the Public user, all restricted users cannot use the Print function.

- 6 Press **Stop/Exit**.

Setting up restricted users

You can set up users with restrictions and a password.

- 1 Press **Menu, 1, 9, 2.**

```

19.Security
  2.Function Lock
▲   Lock Off→On
▼   Set Password
-----
Select ▲▼ or OK
  
```

- 2 Press ▲ or ▼ to select **Setup User**. Press **OK**.
- 3 Enter the administrator password. Press **OK**.

```

19.Security
  Setup User
▲   Public
▼   User01
-----
Select ▲▼ or OK
  
```

- 4 Press ▲ or ▼ to select **User01**. Press **OK**.
- 5 Use the dial pad to enter the user name. (See *Entering text* on page 222.) Press **OK**.
- 6 Enter a four-digit password for the user. Press **OK**.
- 7 Press ▲ or ▼ to select **Enable** or **Disable** for Fax Tx. Press **OK**.
After you have set Fax Tx, repeat this step for Fax Rx, Copy(Color), Copy(B&W) and Scan. Press **OK**.
- 8 Repeat 4 to 7 for entering each additional user and password.
- 9 Press **Stop/Exit**.



Note

You cannot use the same password as another user's password.

Turning Secure Function Lock on/off

If you enter the wrong password when following the instructions below, the LCD will show **Wrong Password**. Re-enter the correct password.

Turning Secure Function Lock on

- 1 Press **Menu, 1, 9, 2.**

```

19.Security
  2.Function Lock
▲   Lock Off→On
▼   Set Password
-----
Select ▲▼ or OK
  
```

- 2 Press ▲ or ▼ to select **Lock Off→On**. Press **OK**.
- 3 Enter your four-digit administrator password. Press **OK**.

Turning Secure Function Lock off

- 1 Press **Menu, 1, 9, 2.**

```

19.Security
  2.Function Lock
▲   Lock On→Off
▼   Change User
-----
Select ▲▼ or OK
  
```

- 2 Press ▲ or ▼ to select **Lock On→Off**. Press **OK**.
- 3 Enter your four-digit administrator password. Press **OK**.

Switching Users

This setting allows a restricted user to log on the machine when Secure Function Lock is turned on.



Note

After a restricted user has finished using the machine, it will return to the Public setting within the same time as the Mode setting within the same time as the Mode Timer setting (**Menu, 1,1**). (See *Mode timer* on page 22. Also, you can exit from an individual user by pressing the lighted Mode key.)

- 1 Hold down **Shift** as you press **Secure**.

Function Lock Change User PIN:XXXX Pls enter PIN

- 2 Enter your four-digit password.
Press **OK**.

When Copy mode is disabled:

- 1 Press **Copy** key.

Access Denied PIN: Pls enter PIN
--

- 2 Enter your four-digit password.
Press **OK**.

When Scan mode is disabled:

- 1 Press **Scan** key.

Access Denied PIN: Pls enter PIN
--

- 2 Enter your four-digit password.
Press **OK**.



Fax

Sending a fax	34
Receiving a fax	44
Telephone services and external devices	50
Dialing and storing numbers	58
Remote fax options (black & white only)	65
Polling	72
Printing reports	74

5

Sending a fax

How to fax

Entering fax mode

To enter fax mode press  (**Fax**), and the key will glow blue.

Sending a single-sided fax from the ADF

Using the ADF to send your faxes is the easiest way. To cancel a fax in progress press **Stop/Exit**.

- 1 Make sure you are in Fax mode .
- 2 Place your document *face up* in the ADF.
- 3 Dial the fax number. (See *How to dial* on page 58.)
- 4 Press **Black Start** or **Color Start**.
 - If you press **Black Start**, the machine scans the pages into memory and then sends the document.
 - If you press **Color Start**, the machine starts dialing and sends the document in real time.



Note

If the **Out of Memory** message appears while scanning a B&W document into memory, press **Stop/Exit** to cancel or **Black Start** to send the scanned pages.

The machine will scan and send your document.

Sending a 2-sided fax from the ADF

You can send a 2-sided document from the ADF. To cancel a fax in progress press **Stop/Exit**.

- 1 Make sure you are in Fax mode .
- 2 Place your document in the ADF.
- 3 Press **Duplex**.
- 4 Dial the fax number. (See *How to dial* on page 58.)
- 5 Press **Black Start**.

The machine will now scan and send your document.



Note

Legal size 2-sided documents can not be faxed from the ADF.

Changing a 2-sided fax layout

You need to choose the duplex scanning format before you send a fax. The format you choose will depend on the layout of your 2-sided document.

- 1 Press **Menu, 1, 0, 2**.

```

10.Document Scan
 2.Duplex Scan
▲ Long edge
▼ Short edge
Select ▲▼ or OK
  
```

- 2 Do one of the following:

- If your document is flipped on the Long edge, press ▲ or ▼ to choose Long edge.

Press **OK**.

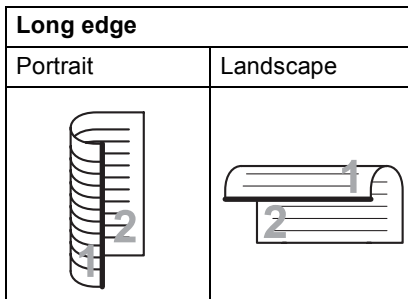

- If your document is flipped on the Short edge, press ▲ or ▼ to choose Short edge.

Press **OK**.

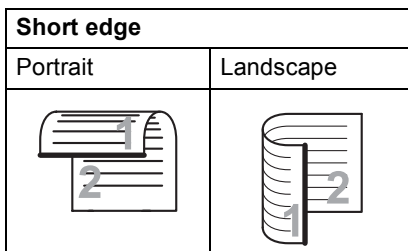

- 3 Press **Stop/Exit**.

Sending a fax from the scanner glass

You can use the scanner glass to fax the pages of a book, or a single page at a time. The documents can be up to Letter or A4, Legal or Folio size. Press **Stop/Exit** to cancel a fax in progress.

You can only send single page color faxes from the scanner glass.

- 1 Make sure you are in Fax mode

- 2 Place your document *face down* on the scanner glass.

- 3 Dial the fax number. (See *How to dial* on page 58.)

- 4 Press **Black Start** or **Color Start**.

- If you press **Black Start**, the machine starts scanning the first page. Go to 5.
- If you press **Color Start**, the machine starts sending. Go to 7.

- 5 After the machine scans the page, the LCD will prompt you to choose one of the options below:

```

Flatbed Fax:
Next Page?
▲ 1.Yes
▼ 2.No (Send)
Select ▲▼ or OK
  
```

- Press **1** to send another page. Go to 6.
- Press **2** or **Black Start** to send the document. Go to 7.

- 6 Place the next page on the scanner glass, press **OK**. Repeat 5 and 6 for each additional page.

```

Flatbed Fax:

Set Next Page
Then Press OK
  
```

- 7 Your machine will automatically send the fax.

 **Note**

When faxing multiple pages from the scanner glass, real time transmission should be set to `Off`.

Faxing legal size documents from the scanner glass

When faxing legal size documents, you need to set the scan glass size to `Legal/Folio` otherwise a portion of your faxes will be missing.

- 1 Make sure you are in Fax mode .

- 2 Press **Menu, 1, 0, 1**.

```
10.Document Scan
 1.Glass ScanSize
▲   A4/Letter
▼   Legal/Folio
Select ▲▼ or OK
```

- 3 Press **▲** or **▼** to choose `Legal/Folio`. Press **OK**.

- 4 Press **Stop/Exit**.

Canceling a fax in progress

Press **Stop/Exit** to cancel a fax in progress. If the machine is already dialing or sending the fax you will also need to press **1** to confirm.

Broadcasting (black & white only)

Broadcasting lets you send the same fax message to more than one fax number. You can include Groups, One-Touch, Speed-Dial numbers and up to 50 manually dialed numbers in the same broadcast.

You can broadcast up to 390 different numbers. This will depend on how many groups, access codes or credit card numbers you have stored, and on how many delayed or stored faxes in memory.

 **Note**

Use the **Search/Speed Dial** to help you choose numbers easily.

- 1 Make sure you are in Fax mode .

- 2 Load your document.

- 3 Enter a number. Press **OK**. You can use either a One-Touch, Speed-Dial, a Group number, or a number manually entered using the dial pad. (See *How to dial* on page 58.)

- 4 Repeat 3 until you have entered all the fax numbers you want to broadcast to.

- 5 Press **Black Start**.

After the broadcast is finished the machine will print a broadcast report to let you know the results.

**Note**

- The scan profile of the One-Touch, Speed-Dial or Group number you chose first will be applied to the broadcast.
- If the fax resolution of the fax number you choose first is *S.Fine* and you enter a stored I-FAX number, *Select Std/Fine* will appear on the LCD. Press **Stop/Exit**. Press **Resolution** and choose *Standard, Fine* or *Photo*, then re-enter the I-FAX number. If you want to enter other numbers, go back to ⑤.

Canceling a broadcast in progress

While broadcasting you can cancel the fax currently being sent or the whole broadcast job.

- 1 Press **Menu**, **2**, **6**.
The LCD will display the fax being dialed (for example, #001 0123456789) and the broadcast job number (for example, Broadcast#001):

```
26.Remaining Jobs
▲ #001 0123456789
▼ Broadcast#001
Select ▲▼ or OK
```

- 2 Press **▲** or **▼** to choose the job number you want to cancel.
Press **OK**.
- 3 Press **1** to clear the job number or **2** to exit.
If you chose to only cancel the fax currently being sent in ②, the machine will ask you if you want to cancel the broadcast. Press **1** to clear the whole broadcast job or **2** to exit.
- 4 Press **Stop/Exit**.

Additional sending operations

Sending faxes using multiple settings

Before you send a fax, you can change any combination of these settings: contrast, resolution, overseas mode, delayed fax timer, polling transmission, real time transmission or cover page settings.

- 1 Make sure you are in Fax mode . After each setting is accepted, the LCD asks if you want to enter more settings:

```
22.Setup Send
   Other Settings?
▲    1.Yes
▼    2.No
Select ▲▼ or OK
```

- 2 Do one of the following:
 - To choose more settings, press **1**.
The LCD returns to the *Setup Send* menu so you can choose another setting.
 - If you have finished choosing settings, press **2** and go to the next step for sending your fax.

Electronic cover page (black & white only)

This feature will *not* work unless you have already programmed your Station ID. (See *the Quick Setup Guide*.)

You can automatically send a cover page with every fax. Your cover page includes your Station ID, a comment, and the name stored in the One-Touch or Speed-Dial memory.

By choosing `Next Fax:On` you can also display the number of pages on the cover page.

You can choose one of the following preset comments.

1. Comment Off
2. Please Call
3. Urgent
4. Confidential

Instead of using one of the preset comments, you can enter two personal messages of your own, up to 27 characters long. Use the chart on page 222 for help entering characters.

(See *Composing your own comments* on page 38.)

5. (User Defined)
6. (User Defined)



Note

You can send the cover page only for a black & white fax. If you press **Color Start** to send a fax, the cover page will not be sent.

Composing your own comments

You can set up two comments of your own.

- 1 Make sure you are in Fax mode .
- 2 Press **Menu, 2, 2, 8**.

```
22.Setup Send
  8.Coverpage Msg
▲      5.
▼      6.
Select ▲▼ or OK
```

- 3 Press ▲ or ▼ to choose 5 or 6 to store your own comment. Press **OK**.
- 4 Enter your own comment using the dial pad. Press **OK**.

Use the chart on page 222 for help entering characters.

Send a cover page for the next fax

If you want to send a cover page only for the next fax, your machine will ask you to enter the number of pages you are sending so it can be printed on the cover page.

- 1 Make sure you are in Fax mode .
- 2 Load your document.
- 3 Press **Menu, 2, 2, 7**.

```
22.Setup Send
  7.Coverpg Setup
▲      Next Fax:On
▼      Next Fax:Off
Select ▲▼ or OK
```

- 4 Press ▲ or ▼ to choose `Next Fax:On` (or `Next Fax:Off`). Press **OK**.
- 5 Press ▲ or ▼ to choose a comment. Press **OK**.

- 6 Enter two digits to show the number of pages you are sending.
Press **OK**.
For example, enter **0, 2** for 2 pages or **0, 0** to leave the number of pages blank. If you make a mistake, press **◀** or **Clear/Back** to back up and re-enter the number of pages.

Send a cover page for all faxes

You can set the machine to send a cover page whenever you send a fax.

- 1 Make sure you are in Fax mode .
- 2 Press **Menu, 2, 2, 7**.

```

22.Setup Send
 7.Coverpg Setup
▲   Next Fax:On
▼   Next Fax:Off
Select ▲▼ or OK

```
- 3 Press **▲** or **▼** to choose **On** (or **Off**).
Press **OK**.
- 4 Press **▲** or **▼** to choose a comment.
Press **OK**.

Using a printed cover page

If you want to use a printed cover page that you can write on, you can print the sample page and attach it to your fax.

- 1 Make sure you are in Fax mode .
- 2 Press **Menu, 2, 2, 7**.

```

22.Setup Send
 7.Coverpg Setup
▲   Next Fax:On
▼   Next Fax:Off
Select ▲▼ or OK

```
- 3 Press **▲** or **▼** to choose **Print Sample**.
Press **OK**.
- 4 Press **Black Start** or **Color Start**. Your machine will print a copy of your cover page.
- 5 Press **Stop/Exit**.

Contrast

For most documents the default setting of **Auto** will give the best results. It automatically chooses the suitable contrast for your document.

If your document is very light or dark, changing the contrast may improve the quality of the fax.

Use **Dark** to make the faxed document lighter.

Use **Light** to make the faxed document darker.

- 1 Make sure you are in Fax mode .
- 2 Load your document.
- 3 Press **Menu, 2, 2, 1**.

```

22.Setup Send
 1.Contrast
▲   Auto
▼   Light
Select ▲▼ or OK

```
- 4 Press **▲** or **▼** to choose **Auto**, **Light** or **Dark**.
Press **OK**.



Note

Even if you choose **Light** or **Dark**, the machine will send the fax using the **Auto** setting if you choose **Photo** as the Fax Resolution.

Changing fax resolution

The quality of a fax can be improved by changing the fax resolution. Resolution can be changed for the next fax *or* for all faxes.

To change the fax resolution for the next fax

- 1 Make sure you are in Fax mode .
- 2 Load your document.
- 3 Press **Resolution**, then **▲** or **▼** to choose the resolution. Press **OK**.

To change the default fax resolution

- 1 Make sure you are in Fax mode .
- 2 Press **Menu**, **2**, **2**, **2**.

```

22.Setup Send
 2.Fax Resolution
▲ Standard
▼ Fine
Select ▲▼ or OK

```

- 3 Press **▲** or **▼** to choose the resolution you want. Press **OK**.



Note

You can choose four different resolution settings for black & white faxes and two for color.

Black & white

Standard:
Suitable for most typed documents.

Fine:
Good for small print and transmits a little slower than Standard resolution.

S.Fine:
Good for small print or artwork and transmits slower than Fine resolution.

Photo:
Use when the document has varying shades of gray or is a photograph. This has the slowest transmission time.

Color

Standard:
Suitable for most typed documents.

Fine:
Use when the document is a photograph. The transmission time is slower than Standard resolution.

If you choose **S.Fine** or **Photo** and then use the **Color Start** key to send a fax, the machine will send the fax using the **Fine** setting.

Dual access (black & white only)

You can dial a number, and start scanning the fax into memory—even when the machine is sending from memory, receiving faxes or printing PC data. The LCD shows the new job number.

The number of pages you can scan into the memory will vary depending on the data that is printed on them.



Note

- Your machine normally uses dual access.
- If you get an **Out of Memory** message while scanning the first page of a fax, press **Stop/Exit** to cancel scanning. If you get an **Out of Memory** message while scanning a subsequent page, you can press **Black Start** to send the pages scanned so far, or press **Stop/Exit** to cancel the operation.

Real time transmission

When you are sending a fax, the machine will scan the documents into the memory before sending. Then, as soon as the telephone line is free, the machine will start dialing and sending.

If the memory is full or you are sending a color fax, the machine will send the document in real time (even if Real Time TX is set to Off).

Sometimes, you may want to send an important document immediately, without waiting for memory transmission. You can set Real Time TX to On for all documents or Next Fax:On for the next fax only.

Sending in real time for all faxes

- 1 Make sure you are in Fax mode .
- 2 Press **Menu, 2, 2, 5**.

```
22.Setup Send
 5.Real Time TX
▲      On
▼      Off
Select ▲▼ or OK
```

- 3 Press ▲ or ▼ to choose On. Press **OK**.

Sending in real time for the next fax only

- 1 Make sure you are in Fax mode .
- 2 Press **Menu, 2, 2, 5**.

```
22.Setup Send
 5.Real Time TX
▲      On
▼      Off
Select ▲▼ or OK
```

- 3 Press ▲ or ▼ to choose Next Fax:On. Press **OK**.



Note

In Real Time Transmission, the automatic redial feature does not work when using the scanner glass.

Overseas mode

If you are having difficulty sending a fax overseas due to a bad connection, then turning on the overseas mode may help.

This is a temporary setting, and will only be active for your next fax.

- 1 Make sure you are in Fax mode .
- 2 Load your document.
- 3 Press **Menu, 2, 2, 9**.

```
22.Setup Send
 9.Overseas Mode
▲      On
▼      Off
Select ▲▼ or OK
```

- 4 Press ▲ or ▼ to choose On (or Off). Press **OK**.

Delayed fax (black & white only)

You can store up to 50 faxes in the memory to be sent within a twenty four hour period.

- 1 Make sure you are in Fax mode .
- 2 Load your document.
- 3 Press **Menu, 2, 2, 3**.

```
22.Setup Send
 3.Delayed Fax

Set Time=00:00
Enter & OK Key
```

- 4 Enter the time you want the fax to be sent (in 24-hour format). (For example, enter 19:45 for 7:45 PM) Press **OK**.

The number of pages you can scan into the memory depends on the amount of data printed on each page.

Delayed batch transmission (black & white only)

Before sending the delayed faxes, your machine will help you economize by sorting all the faxes in the memory by destination and scheduled time.

All delayed faxes that are scheduled to be sent at the same time to the same fax number will be sent as one fax to save transmission time.

1 Make sure you are in Fax mode .

2 Press **Menu, 2, 2, 4**.

```
22.Setup Send
 4.Batch TX
▲   On
▼   Off
Select ▲▼ or OK
```

3 Press ▲ or ▼ to choose *On* (or *Off*). Press **OK**.

4 Press **Stop/Exit**.

Checking and canceling waiting jobs

Check which jobs are still waiting in the memory to be sent. If there are no jobs, the LCD will show *No Jobs Waiting*. You can cancel a fax job that is stored and waiting in the memory.

1 Press **Menu, 2, 6**.

```
26.Remaining Jobs
▲ #001 12:34 BROTHER
  #002 15:00 BIC
▼ #003 17:30 ABCDEFG
Select ▲▼ or OK
```

The number of jobs still to be sent will be displayed.

2 Do one of the following:

- Press ▲ or ▼ to scroll through the waiting jobs, press **OK** to choose a job, and then press **1** to cancel it.
- Press **2** to exit without canceling.

3 When you have finished, press **Stop/Exit**.

Sending a fax manually

Manual transmission

Manual transmission lets you hear the dialing, ringing and fax-receiving tones while sending a fax.

- 1 Make sure you are in Fax mode .
- 2 Load your document.
- 3 Press **Hook** and listen for a dial tone. Or pick up the handset of the external telephone and listen for a dial tone.
- 4 Dial the fax number you want to call.
- 5 When you hear the fax tone, press **Black Start** or **Color Start**.
 - If you are using the scanner glass, press **1** to send a fax.
- 6 If you picked up the handset of an external telephone, replace it.

Sending a fax at the end of a conversation

At the end of a conversation you can send a fax to the other party before you both hang up.

- 1 Ask the other party to wait for fax tones (beeps) and then to press the Start or Send key before hanging up.
- 2 Make sure you are in Fax mode .
- 3 Load your document.
- 4 Press **Black Start** or **Color Start**.
 - If you are using the scanner glass, press **1** to send a fax.
- 5 Replace the handset of an external telephone.

Out of memory message

If you get an *Out of Memory* message while scanning the first page of a fax, press **Stop/Exit** to cancel the fax.

If you get an *Out of Memory* message while scanning a subsequent page, you will have the option to press **Black Start** to send the pages scanned so far, or to press **Stop/Exit** to cancel the operation



Note

If you get an *Out of Memory* message while faxing and you do not want to delete your stored faxes to clear the memory, you can send the fax in real time. (See *Real time transmission* on page 41.)

6

Receiving a fax

Choose the correct Receive Mode

The correct Receive mode is determined by the external devices and telephone subscriber services (Voicemail, Distinctive Ring, etc.) you have (or will be using) on the same line as the Brother machine.

Will you be using a Distinctive Ring number for receiving faxes?

Brother uses the term "Distinctive Ring" but other telephone companies have other names for this service such as Custom Ringing, RingMaster, Personalized Ring, Teen Ring, Ident-A-Call, and Smart Ring. See *Distinctive ring* on page 51 for instruction on setting up your machine using this feature.

Will you be using Voicemail on the same telephone line as your Brother machine?

If you have Voicemail on the same telephone line as your Brother machine, there is a strong possibility that Voice mail and the Brother machine will conflict with each other when receiving incoming calls. See *Voice Mail* on page 50 for instructions on setting up your machine using this service.

Will you be using a Telephone Answering Device on the same telephone line as your Brother machine?

Your external telephone answering device (TAD) will automatically answer every call. Voice messages are stored on the external TAD and fax messages are printed. Choose `External TAD` as your receive mode. See *External TAD* on page 45.

Will you be using your Brother machine on a dedicated fax line?

Your machine automatically answers every call as a fax. Choose `Fax Only` as your receive mode. See *Fax Only* on page 45.

Will you be using your Brother machine on the same line as your telephone?

Do you want to receive voice calls and faxes automatically

The `Fax/Tel` receive mode is used when sharing the Brother machine and your telephone on the same line. Choose `Fax/Tel` as your receive mode. See *Fax/Tel* on page 45.

Important Note: You can not receive voice messages on either Voicemail or an answering machine when choosing the `Fax/Tel` mode.

Do you expect to receive very few faxes?

Choose `Manual` as your receive mode. You control the telephone line and must answer every call yourself. See *Manual* on page 45.

To set the receive mode follow the instructions below.

- 1 Press **Menu**, **0**, **1**.
- 2 Press **▲** or **▼** to choose the receive mode. Press **OK**.
- 3 Press **Stop/Exit**.

The LCD will display the current receive mode.

```
01.Receive Mode
▲ Fax Only
  Fax/Tel
▼ External TAD
Select ▲▼ or OK
```

Using receive modes

Some receive modes answer automatically (**Fax Only** and **Fax/Tel**). You may want to change the ring delay before using these modes. (See *Ring delay* on page 46.)

Fax Only

Fax Only mode will automatically answer every call as a fax.

Fax/Tel

Fax/Tel mode helps you automatically manage incoming calls, by recognizing whether they are fax or voice calls and handling them in one of the following ways:

- Faxes will be automatically received.
- Voice calls will start the **F/T** ring to tell you to pick up the line. The **F/T** ring is a fast double ring made by your machine.

(Also see *F/T ring time* on page 46 and *Ring delay* on page 46.)

Manual

Manual mode turns off all automatic answering functions unless you are using the **Distinctive Ring Receive** feature.

To receive a fax in **Manual** mode lift the handset of the external telephone or press **Hook**. When you hear fax tones (short repeating beeps), press **Black Start** or **Color Start** and then press **2** to receive a fax. You can also use the **Easy Receive** feature to receive faxes by lifting a handset on the same line as the machine.

(Also see *Easy receive* on page 47.)

External TAD

External TAD mode lets an external answering device manage your incoming calls. Incoming calls will be handled in the following ways:

- Faxes will be automatically received.
- Voice callers can record a message on the external TAD.

(For more information see *Connecting an external TAD (telephone answering device)* on page 53.)

Receive mode settings

Ring delay

The ring delay sets the number of times the machine rings before it answers in **Fax Only** and **Fax/Tel** modes.

If you have extension telephones on the same line as the machine or subscribe to the telephone company's Distinctive Ring service, keep the Ring Delay setting of 4. (See *Operation from extension telephones* on page 56 and *Easy receive* on page 47.)

1 Make sure you are in Fax mode .

2 Press **Menu, 2, 1, 1**.

```
21.Setup Receive
 1.Ring Delay
▲      03
▼      04
Select ▲▼ or OK
```

3 Press ▲ or ▼ to choose 00, 01, 02, 03 or 04 for how many times the line rings before the machine answers. Press **OK**.

4 Press **Stop/Exit**.



Note

Choose 00 in 3 to have the machine answer immediately.

F/T ring time

When somebody calls your machine, you and your caller will hear the normal telephone ring sound. The number of rings is set by the ring delay setting.

If the call is a fax, then your machine will receive it; however, if it is a voice call the machine will sound the F/T ring (a fast double-ring) for the time you have set in the F/T ring time setting. If you hear the F/T ring it means that you have a voice caller on the line.

Because the F/T ring is made by the machine, extension and external telephones will *not* ring; however, you can still answer the call on any telephone. (For more information see *Using remote codes* on page 57.)

1 Make sure you are in Fax mode .

2 Press **Menu, 2, 1, 2**.

```
21.Setup Receive
 2.F/T Ring Time
▲      20 Secs
▼      30 Secs
Select ▲▼ or OK
```

3 Press ▲ or ▼ to choose how long the machine will ring to alert you that you have a voice call (20, 30, 40 or 70 seconds). Press **OK**.

4 Press **Stop/Exit**.

Easy receive

Turning **easy receive On** allows the machine to receive fax calls automatically if you lift any handset on the same line as the machine.

When you see **Receiving** on the LCD or when you hear 'chirps' through the handset of an extension telephone connected to another telephone wall jack, just replace the handset and your machine will receive the fax.

If this feature is set to **On**, but your machine does not connect a fax call when you lift the handset of an extension or external telephone, press the Fax Receive Code *51. (See *Operation from extension telephones* on page 56.)



Note

If you use a modem, or send faxes from a computer, on the same line and your machine intercepts them, set easy receive to **Off**.

- 1 Make sure you are in Fax mode .

- 2 Press **Menu, 2, 1, 3**.

```
21.Setup Receive
 3.Easy Receive
▲   On
▼   Off
Select ▲▼ or OK
```

- 3 Press **▲** or **▼** to choose **On** or **Off**. Press **OK**.
- 4 Press **Stop/Exit**.

Setting the print density

You can adjust the print density to make your printed pages darker or lighter.

- 1 Make sure you are in Fax mode .

- 2 Press **Menu, 2, 1, 6**.

```
21.Setup Receive
 6.Print Density
  -□□□□+
Select ◀▶ & OK
```

- 3 Press **▶** to make the print darker. Or, press **◀** to make the print lighter. Press **OK**.
- 4 Press **Stop/Exit**.

Additional receiving operations

Printing a reduced incoming fax

If you choose **On**, the machine automatically reduces each page of an incoming fax to fit on one page of A4, Letter, Legal or Folio size paper.

The machine calculates the reduction ratio by using the page size of the fax and your Paper Size setting (**Menu, 1, 3**).

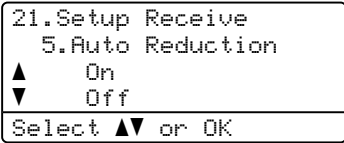
- 1 Make sure you are in Fax mode .
- 2 Press **Menu, 2, 1, 5**.

- 3 Press **▲** or **▼** to choose **On** (or **Off**). Press **OK**.
- 4 Press **Stop/Exit**.

Duplex (2-sided) printing for Fax mode

If you set Duplex to **On** for fax receive the machine will print received faxes on both sides of paper.

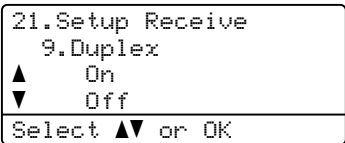
You can use Letter, Legal or Folio (8x13) size of paper for this function.

- 1 Make sure you are in Fax mode .
- 2 Press **Menu, 2, 1, 9**.

- 3 Press **▲** or **▼** to choose **On** (or **Off**). Press **OK**.
- 4 Press **Stop/Exit**.



Note

When you turn Duplex on the auto reduction feature is also turned on.

Setting the fax receive stamp (black & white only)

You can set the machine to print the received date and time in the top center of each received fax page.

1 Make sure you are in Fax mode .

2 Press **Menu, 2, 1, 8**.

```
21.Setup Receive
 8.Fax Rx Stamp
▲   On
▼   Off
Select ▲▼ or OK
```

3 Press **▲** or **▼** to choose On (or Off). Press **OK**.

4 Press **Stop/Exit**.



Note

- The received time and date will not appear when using Internet Fax.
- Make sure you have set the current date and time in the machine.

Receiving a fax at the end of a conversation

At the end of a conversation you can ask the other party to send you a fax before you both hang up.

1 Ask the other person to place the document in their machine and to press the Start or Send key.

2 When you hear the CNG tones (slowly repeating beeps), press **Black Start** or **Color Start**.

3 Press **2** to choose 2.Receive.

4 Replace the external handset.

6

Printing a fax from the memory

If you are using the Fax Storage feature (**Menu, 2, 5, 1**), you can still print a fax from the memory when you are at your machine.

1 Press **Menu, 2, 5, 3**.

```
25.Remote Fax Opt
 3.Print Fax

Press Start
```

2 Press **Black Start** or **Color Start**.

3 Press **Stop/Exit**.

Telephone line services

Voice Mail

If you have Voice Mail on the same telephone line as your Brother machine, Voice Mail and the Brother machine will conflict with each other when receiving incoming calls.

For example, if your Voice Mail is set to answer after 4 rings and your Brother machine is set to answer after 2 rings, then your Brother machine will answer first. This will prevent callers from being able to leave a message in your Voice Mail.

Similarly, if your Brother machine is set to answer after 4 rings and your Voice Mail is set to answer after 2 rings, then your Voice Mail will answer first. This will prevent your Brother machine from being able to receive an incoming fax, since Voice Mail cannot transfer the incoming fax back to the Brother machine.

To avoid conflicts between your Brother machine and your voice mail service, do one of the following:

Get the Distinctive Ring service from your telephone company. Distinctive Ring is a feature of your Brother machine that allows a person with one line to receive fax and voice calls through two different telephone numbers on that one line. Brother uses the term 'Distinctive Ring,' but telephone companies market the service under a variety of names, such as Custom Ringing, Personalized Ring, Smart Ring, RingMaster, Ident-A-Ring, Ident-A-Call, Data Ident-A-Call,

Teen Ring, and SimpleBiz Fax & Alternate Number Ringing. This service establishes a second telephone number on the same line as your existing telephone number, and each number has its own ring pattern. Typically, the original number rings with the standard ring pattern and is used for receiving voice calls, and the second number rings with a different ring pattern and is used for receiving faxes. (See *Distinctive ring* on page 51.)

OR

Set your Brother machine's Receive Mode to "Manual." Manual Mode requires that you answer every incoming call if you want to be able to receive a fax. If the incoming call is a telephone call, then complete the call as you normally would. If you hear fax sending tones you must transfer the call to the Brother machine by pressing * **5 1** on the dial pad of the telephone. Unanswered fax and voice calls will go to your Voice Mail. (To set the machine in **MANUAL** Mode, see *Choose the correct Receive Mode* on page 44.)

Distinctive ring

Brother uses the term 'Distinctive Ring' but different telephone companies have other names for this service such as Custom Ringing, Personalized Ring, RingMaster, Smart Ring, Teen Ring, Ident-A-Call, Data Ident-A-Call, Ident-A-Ring, SimpleBiz Fax & Alternate Number Ringing.

What does your telephone company's 'Distinctive Ring' do?

Your telephone company's Distinctive Ring service allows you to have more than one number on the same telephone line. **If you need more than one telephone number, it is cheaper than paying for an extra line.** Each telephone number has its own distinctive ring pattern, so you will know which telephone number is ringing. This is one way you can have a separate telephone number for your machine.



Note

Please call your telephone company for availability and rates.

What does Brother's 'distinctive ring' do?

The Brother machine has a Distinctive Ring feature that allows you to use your machine to take full advantage of the telephone company's Distinctive Ring service. The new telephone number on your line can just receive faxes.



Note

You must pay for your telephone company's Distinctive Ring service before you program the machine to work with it.

Do you have voice mail?

If you have Voice Mail on the telephone line that you will install your new machine on, *there is a strong possibility that Voice Mail and the machine will conflict with each other while receiving incoming calls.* **However, the Distinctive Ring feature allows you to use more than one number on your line, so both Voice Mail and the machine can work together without any problems.** If each one has a separate telephone number, neither will interfere with the other's operations.

If you decide to get the Distinctive Ring service from the telephone company, you will need to follow the directions below to 'register' the new Distinctive Ring pattern they give you. This is so your machine can recognize its incoming calls.







Note

You can change or cancel the Distinctive Ring pattern at any time. You can switch it off temporarily, and turn it back on later. When you get a new fax number, make sure you reset this feature.

Before you choose the ring pattern to register

You can only register one Distinctive Ring pattern with the machine. Some ring patterns cannot be registered. The ring patterns below are supported by your Brother machine. Register the one your telephone company gives you.

Ring Pattern	Rings	
1	long-long	
2	short-long-short	
3	short-short-long	
4	very long (normal pattern)	



Note

If the ring pattern you received is not on this chart, **please call your telephone company and ask for one that is shown.**

- The machine will only answer calls to its registered number.
- The first two rings are silent on the machine. This is because the fax must <<listen>> to the ring pattern (to compare it to the pattern that was 'registered'). (Other telephones on the same line will ring.)
- If you program the machine properly, it will recognize the registered ring pattern of the 'fax number' within 2 ring patterns and then answer with a fax tone. When the 'voice number' is called, the machine will not answer.

Registering the distinctive ring pattern Very important!

After you have set the Distinctive Ring feature to On, your Distinctive Ring number will receive faxes automatically. The receive mode is automatically set to `Manual` and you cannot change it to another receive mode while Distinctive Ring is set to On. This ensures the Brother machine will only answer the Distinctive Ring number and not interfere when your main telephone number is called.

- 1 Press **Menu, 2, 0, 2.**

```

20.Miscellaneous
 2.Distinctive
▲   Off
▼   Set
Select ▲▼ or OK

```

- 2 Press **▲** or **▼** to choose `Set`.
- 3 Press **OK**.
- 4 Press **▲** or **▼** to choose the prestored ring pattern you want to use. Press **OK**.
- 5 (You will hear each pattern as you scroll through the four patterns. Make sure you choose the pattern that the telephone company gave you.)
- 6 Press **Stop/Exit**. Distinctive Ring is now set to On.

Turning off distinctive ring

- 1 Press **Menu, 2, 0, 2**.

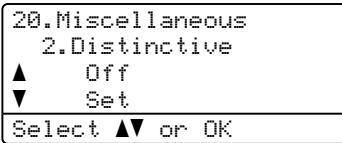

- 2 Press ▲ or ▼ to choose **Off**. Press **OK**.

- 3 Press **Stop/Exit**.



Note

If you don't want to receive faxes on your Distinctive Ring number, you can turn off Distinctive Ring. The machine will stay in *Manual* receive mode so you will need to set the Receive Mode again. (See *Choose the correct Receive Mode* on page 44.)

Connecting an external TAD (telephone answering device)

You can connect an external Telephone Answering Device (TAD) to the same line as your machine. When the TAD answers a call, your machine will “listen” for the CNG (fax calling) tones sent by a sending fax machine. If it hears them it will take over the call and receive the fax. If it does not hear them, it will let your TAD take a voice message and the display will show *Telephone*.

The external TAD must answer within four rings (we recommend you set it to two rings). This is because your machine cannot hear the CNG tones until the external TAD has picked up the call. The sending machine will send CNG tones for only eight to ten seconds longer. We do not recommend using the toll saver feature on your external TAD if it needs more than four rings to activate it.

Unless you are using Distinctive Ring, the TAD must be connected to the EXT jack of the machine.

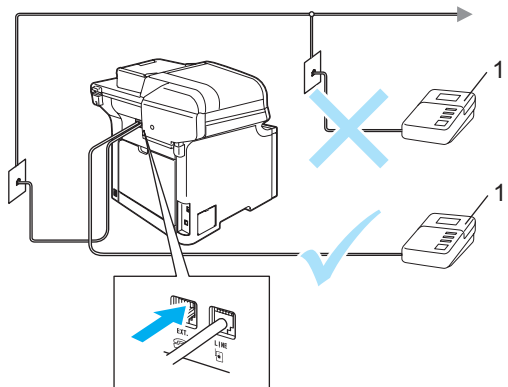

1 TAD



Note

If you have problems receiving faxes, reduce the ring delay setting on your external TAD.

Connections

The external TAD must be plugged into the back of the machine, into the jack labeled EXT. Your machine cannot work properly if you plug the TAD into a wall jack (unless you are using Distinctive Ring).

- 1 Plug the telephone line cord from the telephone wall jack into the back of the machine, in the jack labeled LINE.
- 2 Plug the telephone line cord from your external TAD into the back of the machine, in the jack labeled EXT. (Make sure this cord is connected to the TAD at the TAD's telephone line jack, and not its handset jack.)
- 3 Set your external TAD to four rings or less. (The machine's Ring Delay setting does not apply.)
- 4 Record the outgoing message on your external TAD.
- 5 Set the TAD to answer calls.
- 6 Set the Receive Mode to *External TAD*. (See *Choose the correct Receive Mode* on page 44.)

Recording an outgoing message (OGM)

- 1 Record 5 seconds of silence at the beginning of your message. This allows your machine time to listen for fax tones.
- 2 Limit your speaking to 20 seconds.
- 3 End your 20-second message by giving your Fax Receive Code for people sending manual faxes. For example: "After the beep, leave a message or send a fax by pressing *51 and Start."



Note

We recommend beginning your OGM with an initial 5 second silence because the machine cannot hear fax tones over a loud voice. You may try leaving out this pause, but if your machine has trouble receiving, then you should re-record the OGM to include it.

Special line considerations

Roll over telephone lines

A roll over telephone system is a group of two or more separate telephone lines that pass incoming calls to each other if they are busy. The calls are usually passed down or "rolled over" to the next available telephone line in a preset order.

Your machine can work in a roll over system as long as it is the last number in the sequence, so the call cannot roll away. Do not put the machine on any of the other numbers; when the other lines are busy and a second fax call is received, the fax call would be transferred to a line that does not have a fax machine. **Your machine will work best on a dedicated line.**

Two-line telephone system

A two-line telephone system is nothing more than two separate telephone numbers on the same wall outlet. The two telephone numbers can be on separate jacks (RJ11) or combined into one jack (RJ14). Your machine must be plugged into an RJ11 jack. RJ11 and RJ14 jacks may be equal in size and appearance and both may contain four wires (black, red, green, yellow). To test the type of jack, plug in a two-line telephone and see if it can access both lines. If it can, you must separate the line for your machine. (See *Easy receive* on page 47.)

Converting telephone wall outlets

There are three ways to convert to an RJ11 jack. The first two ways may require assistance from the telephone company. You can change the wall outlets from one RJ14 jack to two RJ11 jacks. Or, you can have an RJ11 wall outlet installed and slave or jump one of the telephone numbers to it.

The third way is the easiest: Buy a triplex adapter. You can plug a triplex adapter into an RJ14 outlet. It separates the wires into two separate RJ11 jacks (Line 1, Line 2) and a third RJ14 jack (Lines 1 and 2). If your machine is on Line 1, plug the machine into L1 of the triplex adapter. If your machine is on Line 2, plug it into L2 of the triplex adapter.

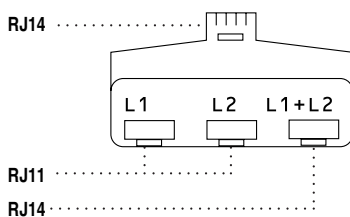

Installing machine, external two-line TAD and two-line telephone

When you are installing an external two-line telephone answering device (TAD) and a two-line telephone, your machine must be isolated on one line at both the wall jack and at the TAD. The most common connection is to put the machine on Line 2, which is explained in the following steps. The back of the two-line TAD must have two telephone jacks: one labeled L1 or L1/L2, and the other labeled L2. You will need at least three telephone line cords, the one that came with your machine and two for your external two-line TAD. You will need a fourth line cord if you add a two-line telephone.

Place the two-line TAD and the two-line telephone next to your machine.

Plug one end of the telephone line cord for your machine into the L2 jack of the triplex adapter. Plug the other end into the LINE jack on the back of the machine.

Plug one end of the first telephone line cord for your TAD into the L1 jack of the triplex adapter. Plug the other end into the L1 or L1/L2 jack of the two-line TAD.

Plug one end of the second telephone line cord for your TAD into the L2 jack of the two-line TAD. Plug the other end into the EXT. jack on the left side of the machine.

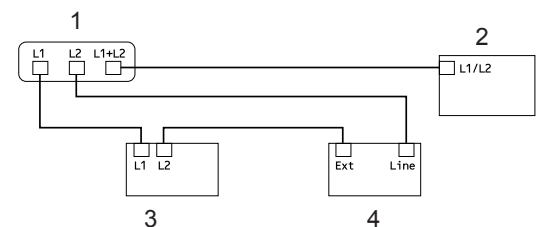

- 1 Triplex Adapter
- 2 Two Line Telephone
- 3 External Two Line TAD
- 4 Machine

You can keep two-line telephones on other wall outlets as always. There are two ways to add a two-line telephone to the machine's wall outlet. You can plug the telephone line cord from the two-line telephone into the L1+L2 jack of the triplex adapter. Or, you can plug the two-line telephone into the TEL jack of the two-line TAD.

Multi-line connections (PBX)

We suggest you ask the company who installed your PBX to connect your machine. If you have a multi line system we suggest you ask the installer to connect the unit to the last line on the system. This prevents the machine being activated each time the system receives telephone calls. If all incoming calls will be answered by a switchboard operator we recommend that you set the Receive Mode to *Manual*.

We cannot guarantee that your machine will operate properly under all circumstances when connected to a PBX. Any difficulties with sending or receiving faxes should be reported first to the company who handles your PBX.

External and extension telephones

Operation from extension telephones

If you answer a fax call on an extension telephone, or an external telephone connected to the EXT. jack of the machine, you can make your machine take the call by using the Fax Receive Code. When you press the Fax Receive Code ***51** the machine starts to receive the fax. (See *Easy receive* on page 47.)

If the machine answers a voice call and pseudo/double-rings for you to take over, use the Telephone Answer Code **#51** to take the call at an extension telephone. (See *F/T ring time* on page 46.)

If you answer a call and no one is on the line:

You should assume that you're receiving a manual fax.

Press ***51** and wait for the chirp or until the machine's LCD shows *Receiving*, and then hang up.

For Fax/Tel mode only

When the machine is in Fax/Tel mode, it will use the F/T Ring Time (pseudo/double-ringing) to alert you to pick up a voice call.

Lift the external telephone's handset, and then press **Hook** to answer.

If you're at an extension telephone, you will need to lift the handset during the F/T Ring Time and then press **#51** between the pseudo/double rings. If no one is on the line, or if someone wants to send you a fax, send the call back to the machine by pressing ***51**.

Connecting an external or extension telephone

You can connect a separate telephone directly to your machine as shown in the diagram below.

Connect the telephone line cord to the jack labeled EXT.

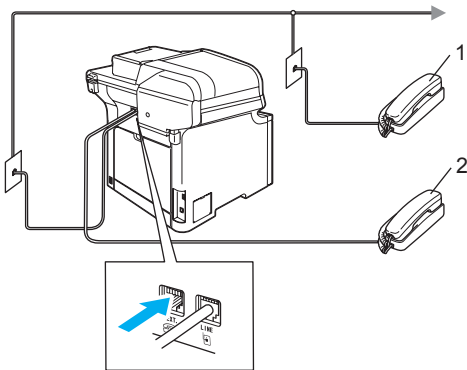

1 Extension telephone

2 External telephone

When you are using an external telephone, the LCD shows *Telephone*.

Using a non-Brother cordless external handset

If your non-Brother cordless telephone is connected to the EXT. jack of the machine (see page 57) and you typically carry the cordless handset elsewhere, it is easier to answer calls during the Ring Delay.

If you let the machine answer first, you will have to go to the machine so you can press **Hook** to transfer the call to the cordless handset.

Using remote codes

Fax Receive Code

If you answer a fax call on an extension or external telephone, you can tell your machine to receive it by pressing the fax receive code ***51**. Wait for the chirping sounds then replace the handset. (See *Easy receive* on page 47.)

Telephone Answer Code

If you receive a voice call and the machine is in F/T mode, it will start to sound the F/T (double-ring) after the initial ring delay. If you pick up the call on an extension telephone you can turn the F/T ring off by pressing **#51** (make sure you press this *between* the rings).

Changing the remote codes

The preset fax receive code is ***51**. The preset telephone answer code is **#51**. If you are always disconnected when accessing your external TAD, try changing the three-digit remote codes, for example **###** and **999**.

1 Make sure you are in Fax mode .

2 Press **Menu 2, 1, 4**.

```
21.Setup Receive
 4.Remote Codes
▲ On
▼ Off
Select ▲▼ or OK
```

3 Press **▲** or **▼** to choose On (or Off). Press **OK**.

4 If you chose On in 3, enter the new Fax Receive Code. Press **OK**.

5 Enter the new Telephone Answer Code. Press **OK**.

6 Press **Stop/Exit**.

8

Dialing and storing numbers

How to dial

You can dial in any of the following ways.

Manual dialing

Use the dial pad to enter all the digits of the telephone or fax number.



One-touch dialing

Press the One-Touch key that stores the number you want to call. (See *Storing one-touch dial numbers* on page 60.)

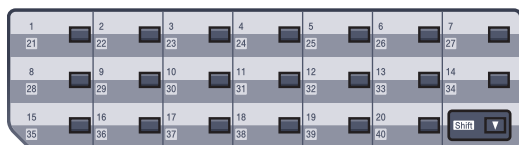

To dial One-Touch numbers 21 to 40, hold down **Shift** as you press the One-Touch key.

Speed-dialing

Hold down **Shift** as you press **Search/Speed Dial**, and then enter the three-digit Speed-Dial number. (See *Storing speed-dial numbers* on page 61.)

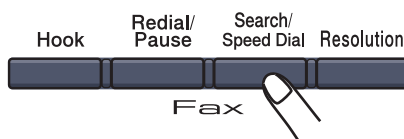
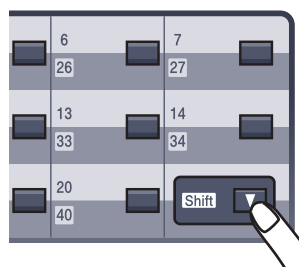

Three-digit number



Note

If the LCD shows **Not Registered** when you enter a One-Touch or a Speed-Dial number, it means that a number is not stored there.

Search

You can search alphabetically for names you have stored in the One-Touch and Speed-Dial memories. (See *Storing one-touch dial numbers* on page 60 and *Storing speed-dial numbers* on page 61.)

- 1 Press **Search/Speed Dial**.
- 2 Press the dial pad key for the first letter of the name.
(Use the chart on *Entering text* on page 222 to help you enter letters.) Press **OK**.
- 3 Press **▲** or **▼** to scroll until you find the name you are looking for. Press **OK**.



Note

You can press **Resolution** to change the displayed resolution.

- 4 Press **Black Start** or **Color Start**.

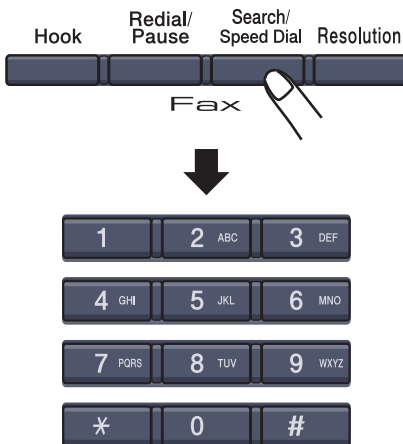

Note

- If you do not enter a letter and Press **OK** in 2, all registered names will appear. Press **▲** or **▼** to scroll until you find the name you are looking for.
- If the LCD shows **No Contact Found** when you enter the first letter of the name, it means that a name for the letter is not stored.

LDAP Search

If the machine is connected to your LDAP server, you can search for information such as fax numbers and E-mail addresses from your server. (For details about how to set up LDAP see *the Network User's Guide on the CD-ROM*.)

Fax redial

If you are sending a fax manually and the line is busy, press **Redial/Pause**, wait for the other fax machine to answer, and then press **Black Start** or **Color Start** to try again. If you want to make a second call to the last number dialed, you can save time by pressing **Redial/Pause** and **Black Start** or **Color Start**.

Redial/Pause only works if you dialed from the control panel.

If you are sending a fax automatically and the line is busy, the machine will automatically redial one time after five minutes.

Storing numbers

You can set up your machine to do the following types of easy dialing: One-Touch, Speed-Dial and Groups for Broadcasting faxes. You can also specify the default resolution for each One-Touch and Speed-Dial number. When you dial a quick-dial number, the LCD shows the name, if you stored it, or the number. A scan profile can also be stored along with the fax number or E-mail address.

If you lose electrical power, the quick-dial numbers stored in the memory will not be lost.

A scan profile is the resolution and other scan settings that you choose when you store a number. For example, you will be asked to select Standard, Fine, S.Fine or Photo if you have selected the Fax/Tel option. Or, you will be asked to select B/W 200 dpi, B/W 200x100 dpi, Color 150 dpi, Color 300 dpi or Color 600 dpi if you selected the E-Mail option.

Storing a pause

Press **Redial/Pause** to insert a 3.5-second pause between numbers. You can press **Redial/Pause** as many times as needed to increase the length of the pause.

Storing one-touch dial numbers

Your machine has 20 One-Touch keys where you can store 40 fax or telephone numbers or E-mail addresses for automatic dialing. To access numbers 21 to 40, hold down **Shift** as you press the One-Touch key.

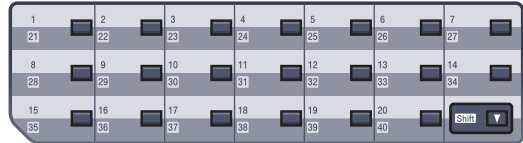

- 1 Press **Menu**, **2**, **3**, **1**.

```
23.Set Quick-Dial
  1.One-Touch Dial

One-Touch:
Select One-Touch
```

- 2 Press the One-Touch key where you want to store a number.
- 3 Press **▲** or **▼** to select Fax/Tel, E-Mail or IFAX. Press **OK**.
- 4 Choose one of the options below:
 - Enter the number (up to 20 characters) if you selected Fax/Tel. Press **OK**.
 - Enter the E-mail address (up to 60 characters) if you selected E-Mail or IFAX. Use the chart on *Entering text* on page 222 to help you enter letters. Press **OK**.



Note

If you selected E-Mail and save the E-mail address, you can only use the E-mail address when you are in Scan mode. If you selected IFAX and save the E-mail address, you can only use the E-mail address when you are in Fax mode.

- 5 Choose one of the options below:
- Enter the name using the dial pad (up to 15 characters). Press **OK**.
 - Press **OK** to store the number or E-mail address without a name.
- 6 If you want to save a fax/scan resolution along with the number, choose one of the options below:
- If you selected Fax/Tel in 3, press ▲ or ▼ to select Std, Fine, S. Fine or Photo. Press **OK** and then go to 6.
 - If you selected E-Mail in 3, press ▲ or ▼ to select B/W200dpi, B/W200x100, Color150dpi, Color300dpi or Color600dpi. Press **OK** and then go to 7.
 - If you selected IFAX in 3, press ▲ or ▼ to select Std, Fine or Photo. Press **OK** and then go to 8.
 - Press **OK** if you don't want to change the default resolution. Go to 8.
- 7 Choose one of the options below: If you selected Black & White in 6, select the file format (TIFF or PDF) that will be used to send to your PC. If you selected Color in 6, select the file format (PDF or JPEG) that will be used to send your PC. Press **OK**
- 8 Choose one of the options below:
- To store another One-Touch number go to 2.
 - To finish storing One-Touch numbers press **Stop/Exit**.



Note

When you do a broadcast and you have saved a scan profile along with the number or E-mail address, the scan profile of the One-Touch, Speed-Dial or Group number you chose first will be applied to the broadcast.

Storing speed-dial numbers

You can store your frequently used numbers as Speed-Dial numbers, so that when you dial you will only have to press a few keys (hold down **Shift** as you press **Search/Speed Dial**, the three-digit number, and **Black Start** or **Color Start**). The machine can store 300 Speed-Dial numbers (001 - 300).

- 1 Press **Menu**, **2**, **3**, **2**.

```
23.Set Quick-Dial
 2.Speed-Dial

Speed-Dial? #
Enter & OK Key
```

- 2 Use the dial pad to enter a three-digit Speed-Dial location number (001-300). Press **OK**.
- 3 Press ▲ or ▼ to select Fax/Tel, E-Mail or IFAX. Press **OK**.
- 4 Choose one of the options below:
- Enter the number (up to 20 characters) when you select Fax/Tel. Press **OK**
 - Enter the E-mail address (up to 60 characters) if you selected E-Mail or IFAX. Use the chart on *Entering text* on page 222 to help you enter letters. Press **OK**.



Note

If you selected E-Mail and save the E-mail address, you can only use the E-mail address when you are in Scan mode. If you selected IFAX and save the E-mail address, you can only use the E-mail address when you are in Fax mode.

- 5 Choose one of the options below:
 - Enter the name using the dial pad (up to 15 characters). Press **OK**.
 - Press **OK** to store the number or E-mail address without a name.
- 6 If you want to save a fax/scan resolution along with the number, choose one of the options below:
 - If you selected Fax/Tel in 3, press ▲ or ▼ to select Std, Fine, S. Fine or Photo. Press **OK** and then go to 8.
 - If you selected E-Mail in 3, press ▲ or ▼ to select B/W200dpi, B/W200x100, Color150dpi, Color300dpi or Color600dpi. Press **OK** and then go to 7.
 - If you selected IFAX in 3, press ▲ or ▼ to select Std, Fine or Photo. Press **OK** and then go to 8.
 - Press **OK** if you don't want to change the default resolution. Go to 8.
- 7 If you selected Black & White in 6, select the file format (TIFF or PDF) that will be used to send to your PC. If you selected Color in 6, select the file format (PDF or JPEG) that will be used to send your PC. Press **OK**
- 8 Choose one of the options below:
 - To store another Speed-Dial number go to 2.
 - To finish storing Speed-Dial numbers press **Stop/Exit**.



Note

When you do a broadcast and you have saved a scan profile along with the number or E-mail address, the scan profile of the One-Touch, Speed-Dial or Group number you chose first will be applied to the broadcast.

Changing one-touch and speed-dial numbers

If you try to store a One-Touch or Speed-Dial number over an existing number, the LCD will show the name or number already stored there.

- 1 Do one of the following:
 - To change the stored number, press **1**.
 - To exit without making a change, press **2**.

```

23.Set Quick-Dial
   #005:MIKE
▲      1.Change
▼      2.Exit
Select ▲▼ or OK

```

- 2 Press ▲ or ▼ to select Fax/Tel, E-Mail or IFAX. Press **OK**.
- 3 Enter a new number or character. Press **OK**.
- 4 Press ◀ or ▶ to position the cursor under the character you want to change, and then press **Clear/Back** to delete it. Repeat for each character you want to delete.
- 5 Follow the directions beginning in 6 in Storing one-touch dial numbers and Storing Speed-Dial numbers. (See *Storing one-touch dial numbers* on page 60 and *Storing speed-dial numbers* on page 61.)

Setting up groups for broadcasting

If you often want to send the same fax message to many fax numbers you can set up a group.

Groups are stored on a One-Touch key or a Speed-Dial number. Each group uses up a One-Touch key or a Speed-Dial location. You can then send the fax message to all the numbers stored in a group just by pressing a One-Touch key or entering a Speed-Dial number, and then pressing **Black Start**.

Before you can add numbers to a group, you need to store them as One-Touch or Speed-Dial numbers. You can have up to 20 small groups, or you can assign up to 339 numbers to one large group.

- 1 Press **Menu**, **2**, **3**, **3**.

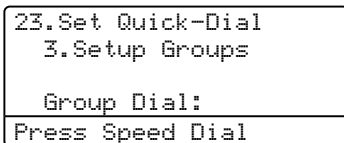

- 2 Choose an empty location where you want to store the group in one of the following ways:
 - Press a One-Touch key.
 - Hold down **Shift** as you press **Search/Speed Dial** and then enter the three-digit Speed-Dial location. Press **OK**.
- 3 Use the dial pad to enter a group number (01 to 20). Press **OK**.
- 4 Press **▲** or **▼** to select **Fax/IFAX** or **E-Mail**. Press **OK**.

- 5 To add One-Touch or Speed-Dial numbers follow the instructions below:
 - For One-Touch numbers, press the One-Touch keys one after the other.
 - For Speed-Dial numbers, hold down **Shift** as you press **Search/Speed Dial**, and then enter the three-digit Speed-Dial location.

The LCD will display your chosen One-Touch numbers with a * and Speed-Dial numbers with a # (for example *006, #009).

- 6 Press **OK** when you have finished adding numbers.
- 7 Do one of the following:
 - Enter the name using the dial pad (up to 15 characters). Use the chart on *Entering text* on page 222 to help you enter letters. Press **OK**.
 - Press **OK** to store the group without a name.
- 8 You can save a fax/scan resolution along with the number. Do one of the following:
 - If you selected **Fax/IFAX** in 4, press **▲** or **▼** to select **Std**, **Fine**, **S.Fine** or **Photo**. Press **OK** and then go to 10.
 - If you selected **E-Mail** in 4, press **▲** or **▼** to select **B/W200x100**, **B/W200dpi**, **Color150dpi**, **Color300dpi** or **Color600dpi**. Press **OK** and then go to 9.
 - Press **OK** if you don't want to change the default resolution. Go to 10.



Note

If you have selected **Fax/IFAX** in 4 and added One-Touch or Speed-Dial numbers that are stored as 'IFAX', you cannot select **S.Fine**.

- 9 If you selected **B/W200dpi** or **B/W200x100** in 8, select the file format (TIFF or PDF) that will be used to send to your PC. If you selected **Color150dpi**, **Color300dpi** or **Color600dpi** in 8, select the file format (PDF or JPEG) that will be used to send your PC. Press **OK**.
- 10 Do one of the following:
- To store another group for broadcasting, press **OK**. Go to 2.
 - To finish storing groups for broadcasting, press **Stop/Exit**.



Note

Fax Broadcasting is for black & white only.

Dialing access codes and credit card numbers

You can combine more than one Quick-Dial number when you dial. This feature may be useful if you need to dial an access code for a cheaper rate from another long distance carrier.

For example, you might have stored '555' on Speed-Dial #003 and '7000' on Speed-Dial #002. You can use them both to dial '555-7000' if you press the following keys:

Hold down **Shift** as you press **Search/Speed Dial, 003**. Hold down **Shift** as you press **Search/Speed Dial, 002** and **Black Start** or **Color Start**.

Numbers can be added manually by entering them on the dial pad:

Hold down **Shift** as you press **Search/Speed Dial, 003, 7001** (on the dial pad), and **Black Start** or **Color Start**.

This would dial '555-7001'. You can also add a pause by pressing the **Redial/Pause** key.

Pause

Press **Redial/Pause** to insert a 3.5-second pause between numbers. You can press **Redial/Pause** as many times as needed to increase the length of the pause.

Tone or pulse (Canada only)

If you have a Pulse dialing service, but need to send Tone signals (for example, for telephone banking), follow the instructions below. If you have Touch Tone service, you will not need this feature to send tone signals.

- 1 Press **Hook**.
- 2 Press **#** on the machine's control panel. Any digits dialed after this will send tone signals. When you hang up, the machine will return to the Pulse dialing service.

9

Remote fax options (black & white only)

Remote fax options **ARE NOT** available for color fax.

Remote fax options let you receive faxes while you are away from the machine.

You can use *only one* remote fax option at a time.

Fax forwarding

The fax forwarding feature lets you automatically forward your received faxes to another machine.

- 1 Press **Menu**, **2**, **5**, **1**.

```
25.Remote Fax Opt
  1.Fwd/Page/Store
▲   Off
▼   Fax Forward
Select ▲▼ or OK
```

- 2 Press ▲ or ▼ to choose **Fax Forward**. Press **OK**.

The LCD will ask you to enter the fax number you want your faxes to be forwarded to.

- 3 Enter the forwarding number using the dial pad (up to 20 digits), using a One-Touch key or holding down **Shift** as you press **Search/Speed Dial** and the three-digit location.

Note

- If you store a group on a One-Touch key or a Speed Dial location, the faxes will be forwarded to several fax numbers.
- You can also enter an E-mail address if your machine has been configured for the Internet Fax feature. (For details about Internet Fax, see *the Network User's Guide on the CD-ROM*. For information about Fax Forward to E-mail, see the Brother Solutions Center at <http://solutions.brother.com>)

- 4 Press **OK**.

- 5 Press ▲ or ▼ to choose **On** or **Off**.

```
25.Remote Fax Opt
  Backup Print
▲   Off
▼   On
Select ▲▼ or OK
```

Press **OK**.

- 6 Press **Stop/Exit**.



Note

If you choose Backup Print On, the machine will also print the fax at your machine so you will have a copy. This is a safety feature in case there is a power failure before the fax is forwarded or a problem at the receiving machine. The machine can store faxes up to 60 hours if there is a power failure.

Paging

When Paging is chosen, your machine dials the pager number you've programmed, and then dials your Personal Identification Number (PIN). This activates your pager so you will know that you have a fax message in the memory.

- 1 Press **Menu, 2, 5, 1**.

```
25.Remote Fax Opt
 1.Fwd/Page/Store
▲   Off
▼   Fax Forward
-----
Select ▲▼ or OK
```

- 2 Press **▲** or **▼** to choose **Paging**. Press **OK**.
- 3 Enter your pager telephone number followed by **# #** (up to 20 digits). Press **OK**.
Do not include the area code if it is the same as that of your machine.
For example, press **1 8 0 0 5 5 1 2 3 4 # #**.
- 4 Do one of the following:
 - If your pager needs a PIN, enter the PIN, press **#**, press **Redial/Pause**, enter your fax number followed by **# #**.
Press **OK**.
(For example, press:
1 2 3 4 5 # Redial/Pause 1 8 0 0 5 5 5 6 7 8 9 # #)
 - If you do not need a PIN, press **OK**.
- 5 Press **Stop/Exit**.



Note

- You cannot change a Paging number or PIN remotely.
- If you have set Paging, a backup copy will automatically be printed at the machine.

Fax storage

The fax storage feature lets you store your received faxes in the machine's memory. You can retrieve stored fax messages from a fax machine at another location using the remote retrieval commands. (See *Retrieving fax messages* on page 70.) Your machine will automatically print a copy of the stored fax.

- 1 Press **Menu, 2, 5, 1**.

```
25.Remote Fax Opt
 1.Fwd/Page/Store
▲   Off
▼   Fax Forward
-----
Select ▲▼ or OK
```

- 2 Press **▲** or **▼** to choose **Fax Storage**. Press **OK**.
- 3 Press **Stop/Exit**.



Note

If Fax Storage is turned on your machine cannot receive a color fax unless the sending machine converts it to black & white.

PC fax receive

If you turn on the PC Fax Receive feature your machine will store received faxes in memory and send them to your PC automatically. You can then use your PC to view and store these faxes.

Even if you have turned off your PC (at night or on the weekend, for example), your machine will receive and store your faxes in its memory. The LCD will show the number of stored faxes received, for example:

PC Fax Msg:001

When you start your PC and the PC Fax Receiving software runs, your machine transfers your faxes to your PC automatically.

To transfer the received faxes to your PC you must have the PC Fax Receive software running on your PC. (See *PC-FAX receiving in Chapter 6 in the Software User's Guide on the CD-ROM.*)

If you choose Backup Print On, the machine will also print the fax.

- 1 Press **Menu, 2, 5, 1**.

```
25.Remote Fax Opt
 1.Fwd/Page/Store
▲   Off
▼   Fax Forward
-----
Select ▲▼ or OK
```

- 2 Press **▲** or **▼** to choose PC Fax Receive.
Press **OK**.

- 3 Press **▲** or **▼** to choose <USB> or your computer name if the machine is connected to a network.

```
25.Remote Fax Opt
 1.Fwd/Page/Store
▲   <USB>
▼   ABC012
-----
Select ▲▼ or OK
```

Press **OK**.

- 4 Press **▲** or **▼** to choose On or Off.

```
25.Remote Fax Opt
 Backup Print
▲   Off
▼   On
-----
Select ▲▼ or OK
```

Press **OK**.

- 5 Press **Stop/Exit**.



Note

If you choose Backup Print On, the machine will also print the faxes at your machine so you will have a copy. This is a safety feature in case there is a power failure before the faxes are forwarded or a problem at the receiving machine. The machine can store faxes up to 60 hours if there is a power failure.

Changing remote fax options

If received faxes are left in your machine's memory when you change the remote fax option to **Off**, the LCD will ask you the following message:

```
25.Remote Fax Opt
Erase All Fax?
▲ 1.Yes
▼ 2.No
Select ▲▼ or OK
```

or

```
25.Remote Fax Opt
Print All Fax?
▲ 1.Yes
▼ 2.No
Select ▲▼ or OK
```

- If you press **1**, faxes in the memory will be erased or printed before the setting changes. If a backup copy has already been printed it will not be printed again.
- If you press **2**, faxes in the memory will not be erased or printed and the setting will be unchanged.

If received faxes are left in the machine's memory when you change to **PC Fax Receive** from another remote fax option (Fax Forward, Paging or Fax Storage), the LCD will ask you the following message:

```
25.Remote Fax Opt
Send Fax to PC?
▲ 1.Yes
▼ 2.No
Select ▲▼ or OK
```

- If you press **1**, faxes in the memory will be sent to your PC before the setting changes. Faxes in the memory will be sent to your PC when the PC Fax Receive icon is active on your PC. (See *the Software User's Guide on the CD-ROM.*)

- If you press **2**, faxes in the memory will not be erased or transferred to your PC and the setting will be unchanged.

The LCD will ask you the following message:

```
25.Remote Fax Opt
Backup Print
▲ Off
▼ On
Select ▲▼ or OK
```

Press **▲** or **▼** to choose **On** or **Off**.

Press **OK**. Press **Stop/Exit**.



Note

If you choose Backup Print On, the machine will also print the fax at your machine so you will have a copy. This is a safety feature in case there is a power failure before the fax is forwarded or a problem at the receiving machine. The machine can store faxes up to 60 hours if there is a power failure.

Turning off remote fax options

- 1 Press **Menu, 2, 5, 1**.

```
25.Remote Fax Opt
1.Fwd/Page/Store
▲ Off
▼ Fax Forward
Select ▲▼ or OK
```

- 2 Press **▲** or **▼** to choose **Off**. Press **OK**.



Note

The LCD will give you options if there are received faxes still in your machine's memory. (See *Changing remote fax options* on page 68.)

- 3 Press **Stop/Exit**.

Remote retrieval

The remote retrieval feature lets you retrieve your stored fax messages when you are not at the machine. You can call your machine from any touch tone telephone or fax machine, then use the Remote Access Code to retrieve your messages.

Setting a remote access code

The remote access code lets you access the remote retrieval features when you are away from your machine. Before you use the remote access and retrieval features, you have to set up your own code. The default code is an inactive code: --*.

- 1 Press **Menu**, **2**, **5**, **2**.

```
25.Remote Fax Opt
 2.Remote Access

Access Code:---*
Enter & OK Key
```

- 2 Enter a three-digit code using numbers **0 – 9**, ***** or **#**. Press **OK**.
- 3 Press **Stop/Exit**.



Note

DO NOT use the same code used for your Fax Receive Code (***51**) or Telephone Answer Code (**#51**). (See *Changing the remote codes* on page 57.)

You can change your code at any time. If you want to make your code inactive, press **Clear/Back** and then **OK** in 2 to restore the inactive setting --*.

Using your remote access code

- 1 Dial your fax number from a telephone or another fax machine using touch tone.
- 2 When your machine answers, immediately enter your Remote Access Code (3 digits followed by *).
- 3 The machine signals if it has received messages:
 - *No beeps*
No messages received.
 - *1 long beep*
Fax message received.
- 4 The machine gives two short beeps to tell you to enter a command. (See *Remote fax commands* on page 71.) The machine will hang up if you wait longer than 30 seconds before entering a command. If you enter an invalid command the machine will beep three times.
- 5 Press **9 0** to reset the machine when you have finished.
- 6 Hang up.



Note

If your machine is set to **Manual** mode, you can still access the remote retrieval features. Dial the fax number as normal and let the machine ring. After 2 minutes you will hear a long beep to tell you to enter the remote access code. You will then have 30 seconds to enter the code.

Retrieving fax messages

- 1 Dial your fax number from a telephone or another fax machine using touch tone.
- 2 When your machine answers, immediately enter your remote access code (3 digits followed by *). If you hear one long beep, you have messages.
- 3 When you hear two short beeps, use the dial pad to press **9 6 2**.
- 4 Wait for a long beep, and then use the dial pad to enter the number of the remote fax machine where you want your fax messages sent to (up to 20 digits), followed by **# #**.
- 5 Hang up after you hear your machine beep. Your machine will call the other machine, which will then print your fax messages.



Note

You can insert a pause in a fax number by using the # key.

Changing the fax forwarding number

You can change the default setting of your fax forwarding number from another telephone or fax machine using touch tone.

- 1 Dial your fax number from a telephone or another fax machine using touch tone.
- 2 When your machine answers, enter your remote access code (3 digits followed by *). If you hear one long beep, you have messages.
- 3 When you hear two short beeps, use the dial pad to press **9 5 4**.
- 4 Wait for a long beep, and then use the dial pad to enter the new number of the remote fax machine where you want your fax messages forwarded (up to 20 digits), followed by **# #**.
- 5 Press **9 0** to reset the machine when you have finished.
- 6 Hang up after you hear your machine beep.



Note

You can insert a pause in a fax number by using the # key.

Remote fax commands

Follow the commands below to access features when you are away from the machine. When you call the machine and enter your Remote Access Code (3 digits followed by *), the system will give two short beeps and you must enter a remote command.

Remote commands		Operation details
95	Change the fax forwarding, paging or fax storage settings	
	1 OFF	You can choose <code>OFF</code> after you have retrieved or erased all your messages.
	2 Fax forwarding	One long beep means the change is accepted. If you hear three short beeps, you cannot make the change because something has not been set up (for example, a fax forwarding or paging number has not been registered). You can register your fax forwarding number by entering 4. (See <i>Changing the fax forwarding number</i> on page 70.) Once you have registered the number, fax forwarding will work.
	3 Paging	
	4 Fax forwarding number	
6 Fax storage		
96	Retrieve a fax	
	2 Retrieve all faxes	Enter the number of a remote fax machine to receive stored fax messages. (See <i>Retrieving fax messages</i> on page 70.)
	3 Erase faxes from the memory	If you hear one long beep, fax messages have been erased from the memory.
97	Check the receiving status	
	1 Fax	You can check whether your machine has received any faxes. If yes, you will hear one long beep. If no, you will hear three short beeps.
98	Change the receive mode	
	1 External TAD	If you hear one long beep, your change has been accepted.
	2 Fax/Tel	
	3 Fax Only	
90	Exit	Press 9 0 to exit remote retrieval. Wait for the long beep, then replace the handset.

10

Polling

Polling lets you set up your machine so other people can receive faxes from you, but they pay for the call. It also lets you call somebody else's fax machine and receive a fax from it, so you pay for the call. The polling feature needs to be set up on both machines for this to work. Not all fax machines support polling.

Polling receive

Polling receive lets you call another fax machine to receive a fax.

- 1 Make sure you are in Fax mode .
- 2 Press **Menu, 2, 1, 7**.

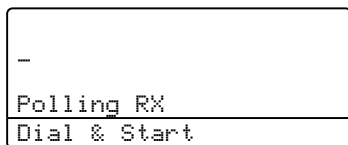

- 3 Enter the fax number you are polling. Press **Black Start** or **Color Start**. The LCD shows *Dialing*.

Sequential polling

Sequential polling lets you request documents from several fax machines in one operation. Afterwards, a Sequential Polling Report will be printed.

- 1 Make sure you are in Fax mode .
- 2 Press **Menu, 2, 1, 7**.

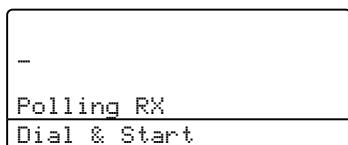

- 3 Specify the fax machines you want to poll by using One-Touch, Speed-Dial, Search, a Group and or the dial pad. You must press **OK** between each location.

- 4 Press **Black Start** or **Color Start**. The machine polls each number or Group number in turn for a document.

Press **Stop/Exit** while the machine is dialing to cancel the polling process.

To cancel all sequential polling receive jobs, press **Menu, 2, 6**. (See *Checking and canceling waiting jobs* on page 42.)

Polled transmit (black & white only)

Polled transmit lets you set up your machine to wait with a document so another fax machine can call and retrieve it.

Setup for polled transmit

- 1 Make sure you are in Fax mode .

- 2 Load your document.

- 3 Press **Menu, 2, 2, 6**.

```
22.Setup Send
 6.Polled TX
▲ On
▼ Off
Select ▲▼ or OK
```

- 4 Press **▲** or **▼** to choose On (or Off). Press **OK**.

- 5 Press **2** to choose 2.No if you don't want to enter more settings when the LCD asks you the following message:

```
22.Setup Send
 Other Settings?
▲ 1.Yes
▼ 2.No
Select ▲▼ or OK
```

- 6 Press **Black Start**.

- 7 If you are using the scanner glass, the LCD will prompt you to choose one of the options below:

```
Flatbed Fax:
 Next Page?
▲ 1.Yes
▼ 2.No (Send)
Select ▲▼ or OK
```

- Press **1** to send another page. Go to **8**.
- Press **2** or **Black Start** to send the document.

- 8 Place the next page on the scanner glass, press **OK**. Repeat **7** and **8** for each additional page.

```
Flatbed Fax:
 Set Next Page
 Then Press OK
```



Note

The document will be stored and can be retrieved from any other fax machine until you delete the fax from memory.

To delete the fax from memory, press **Menu, 2, 6**. (See *Checking and canceling waiting jobs* on page 42.)

11

Printing reports

Fax reports

Some fax reports (transmission verification and fax journal) can be printed automatically and manually.

Transmission verification report

You can use the transmission report as proof that you sent a fax. This report lists the time and date of transmission and whether the transmission was successful (shown as "OK"). If you choose **On** or **On+Image**, the report will print for every fax you send.

If you send a lot of faxes to the same place, you may need more than the job numbers to know which faxes you must send again. Choosing **On+Image** or **Off+Image** will print a section of the fax's first page on the report to help you remember.

When the verification report is turned **Off** or to **Off+Image**, the report will *only* print if there is a transmission error.

- 1 Press **Menu, 2, 4, 1**.

```
24.Report Setting
 1.Transmission
▲      Off
▼      Off+Image
Select ▲▼ or OK
```

- 2 Press **▲** or **▼** to choose **On**, **On+Image**, **Off** or **Off+Image**. Press **OK**.
- 3 Press **Stop/Exit**.

Fax journal

You can set the machine to print a fax journal (activity report) at specific intervals (every 50 faxes, 6, 12 or 24 hours, 2 or 7 days). The default setting is **Every 50 Faxes**, this means that your machine will print the journal when the machine has stored 50 jobs.

If you set the interval to **Off**, you can still print the report by following the steps on the next page.

- 1 Press **Menu, 2, 4, 2**.

```
24.Report Setting
 2.Journal Period
▲      Every 50 Faxes
▼      Every 6 Hours
Select ▲▼ or OK
```

- 2 Press **▲** or **▼** to choose an interval. Press **OK**.

If you choose 7 days, you will be asked to choose a day when you want the 7 day countdown to begin.

- 3 Enter the time to begin printing, in 24 hour format. Press **OK**.

For example: enter 19:45 for 7:45 PM.

- 4 Press **Stop/Exit**.

If you choose 6, 12, 24 hours, 2 or 7 days, the machine will print the report at the selected time and then erase all jobs from its memory. If the machine's memory becomes full with 200 jobs before the time you chose has passed, the machine will print the journal early and then erase all jobs from memory.

If you want an extra report before it is due to print, you can print it manually without erasing the jobs from memory.

Reports

The following reports are available:

- 1 **Transmission**
Displays the Transmission Verification Report for your last outgoing 200 faxes and prints the last report.
- 2 **Help List**
Prints a list of commonly used functions to help you program your machine.
- 3 **Tel Index List**
Prints a list of names and numbers stored in the One-Touch and Speed-Dial memory in numerical or alphabetical order.
- 4 **Fax Journal**
Prints a list of information about your last 200 incoming and outgoing faxes. (TX: transmit.) (RX: receive.)
- 5 **User Settings**
Print a list of your current settings.
- 6 **Network Config**
Lists your network settings.

How to print a report

- 1 Press **Menu, 6**.

```

6.Print Reports
 1.Transmission
 2.Help List
 3.Tel Index List
-----
Select ▲▼ or OK
  
```

- 2 Do one of the following:
 - Press ▲ or ▼ to choose the report you want.
Press **OK**.
 - Enter the number of the report you want to print. For example, press **2** to print the help list.
- 3 Press **Black Start** or **Color Start**.
- 4 Press **Stop/Exit**.



Copy

Making copies

78

12

Making copies

How to copy

Entering copy mode

Press  (Copy) to enter Copy mode.

```
1 — Contrast:-□□■□□+
2 — Quality :Auto
3 — Enlg/Red:100%
4 — Tray      :MP>T1
   ————— 01 — 5
   Press ▲▼ or Start
```

```
Quality :Auto
Enlg/Red:100%
Tray      :MP>T1
6 — Bright  :-□□■□□+
   ————— 01
   Select ◀▶ & OK
```

- 1 Contrast
- 2 Quality
- 3 Copy ratio
- 4 Tray selection
- 5 Number of copies
- 6 Brightness

Making a single copy

- 1 Make sure you are in Copy mode .
- 2 Load your document.
- 3 Press **Black Start** or **Color Start**.

Making multiple copies

- 1 Make sure you are in Copy mode .
- 2 Load your document.
- 3 Use the dial pad to enter the number of copies (up to 99).
- 4 Press **Black Start** or **Color Start**.



Note

(To sort your copies, see *Sorting copies using the ADF* on page 83.)

If the LCD shows “Please Wait” and the machine stops copying while you are making multiple copies, please wait for 30 to 40 seconds until the machine finishes the color registration and cleaning process of the belt unit.

Stop copying

To stop copying, press **Stop/Exit**.

Copy options (temporary settings)

When you want to quickly change the copy settings temporarily for the next copy, use the temporary **Copy** keys. You can use different combinations.

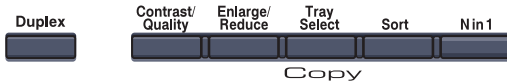

The machine returns to its default settings one minute after copying, unless you have set the Mode Timer to 30 seconds or less. (See *Mode timer* on page 22.)

Improving copy quality

You can choose from a range of quality settings. The default setting is *Auto*.

■ **Auto**

Auto is the recommended mode for ordinary printouts. Suitable for documents that contain both text and photographs.

■ **Text**

Suitable for documents containing only text.

■ **Photo**

Suitable for copying photographs.

To temporarily change the quality setting, follow the steps below:

- 1 Make sure you are in Copy mode .
- 2 Load your document.
- 3 Use the dial pad to enter the number of copies (up to 99).
- 4 Press **Contrast/Quality**. Press **▲** or **▼** to choose *Quality*. Press **OK**.
- 5 Press **◀** or **▶** to choose *Auto*, *Text* or *Photo*. Press **OK**.

- 6 Press **Black Start** or **Color Start**.

To change the *default* setting, follow the steps below:

- 1 Press **Menu, 3, 1**.

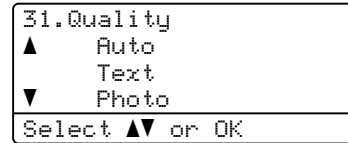

- 2 Press **▲** or **▼** to choose the copy quality. Press **OK**.
- 3 Press **Stop/Exit**.

Enlarging or reducing the image copied

You can choose the following enlargement or reduction ratios:

Press 	100%*
	104% EXE→LTR
	141% A5→A4
	200%
	Custom (25-400%)
	50%
	70% A4→A5
	78% LGL→LTR
	83% LGL→A4
	85% LTR→EXE
	91% Full Page
	94% A4→LTR
97% LTR→A4	

Custom (25-400%) allows you to enter a ratio from 25% to 400%.

To enlarge or reduce the next copy follow the instructions below:

- 1 Make sure you are in Copy mode .
- 2 Load your document.
- 3 Use the dial pad to enter the number of copies (up to 99).
- 4 Press **Enlarge/Reduce**. Press **▶**.
- 5 Do one of the following:
 - Press **▲** or **▼** to choose the enlargement or reduction ratio you want.
Press **OK**.
 - Press **▲** or **▼** to choose Custom (25–400%).
Press **OK**.
Use the dial pad to enter an enlargement or reduction ratio from 25% to 400%. (For example, press **5 3** to enter 53%.)
Press **OK**.
- 6 Press **Black Start** or **Color Start**.



Note

Page Layout Options 2 in 1(P), 2 in 1(L), 4 in 1(P) or 4 in 1(L) are *not* available with Enlarge/Reduce.

Making N in 1 copies (page layout)

You can reduce the amount of paper used when copying by using the N in 1 copy feature. This allows you to copy two or four pages onto one page, which lets you save paper.

Important

- Please make sure the paper size is set to Letter, A4, Legal or Folio.
- (P) means Portrait and (L) means Landscape.
- You cannot use the Enlarge/Reduce setting with the N in 1 feature.

- 1 Make sure you are in Copy mode .
- 2 Load your document.
- 3 Use the dial pad to enter the number of copies (up to 99).
- 4 Press **N in 1**.
- 5 Press **▲** or **▼** to choose 2 in 1 (P), 2 in 1 (L), 4 in 1 (P), 4 in 1 (L) or Off (1 in 1). Press **OK**.
- 6 Press **Black Start** or **Color Start** to scan the page.
If you placed the document in the ADF, the machine scans the pages and starts printing.
If you are using the scanner glass, go to 7.
- 7 After the machine scans the page, press **1** to scan the next page.

```
Flatbed Copy:
Next Page?
▲ 1.Yes
▼ 2.No
Select ▲▼ or OK
```

- 8 Place the next page on the scanner glass. Press **OK**. Repeat 7 and 8 for each page of the layout.

- 9 After all the pages have been scanned, press **2** in 7 to finish.

If you are copying from the ADF:

Insert your document face up in the direction shown below:

■ **2 in 1 (P)**



■ **2 in 1 (L)**

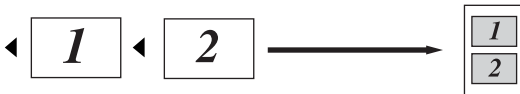

■ **4 in 1 (P)**



■ **4 in 1 (L)**

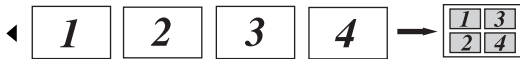

If you are copying from the scanner glass:

Insert your document face down in the direction shown below:

■ **2 in 1 (P)**

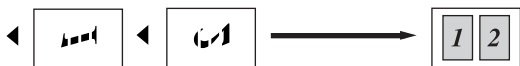

■ **2 in 1 (L)**

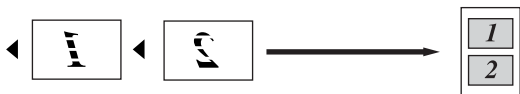

■ **4 in 1 (P)**



■ **4 in 1 (L)**



Duplex (2-sided) copying

You can reduce the amount of paper used when copying by using the duplex copy feature. This allows you to copy on both sides of a sheet of paper.

If you want to use the duplex copy feature, we recommend you load your document in the ADF.

If you get an Out of Memory message while you are making duplex copies, try installing extra memory. (See *Out of memory message* on page 85.)

Duplex Copy (long edge)

■ **1 sided - 2 sided**

Portrait

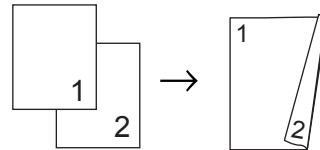

Landscape

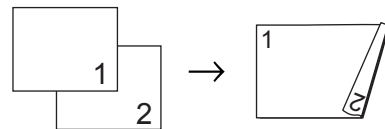

■ **2 sided - 2 sided**

Portrait

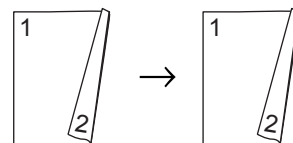

Landscape

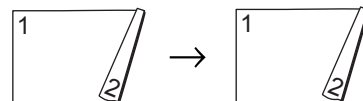

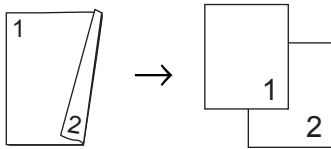

■ **2 sided - 1 sided**

Portrait

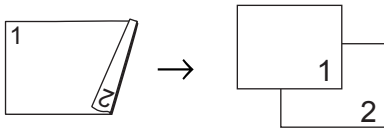

Landscape



- 1 Make sure you are in Copy mode .
- 2 Load your document.
- 3 Use the dial pad to enter the number of copies (up to 99).
- 4 Press **Duplex** and ▲ or ▼ to select
1sided - 2sided,
2sided - 2sided or
2sided - 1sided.

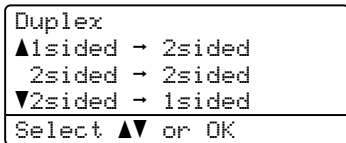

Press **OK**.

- 5 Press **Black Start** or **Color Start** to scan the document.



Note

Duplex copy using a 2-sided legal size document is not available.

Advanced Duplex Copy (short edge)

■ **Advanced 2 sided - 1 sided**

Portrait

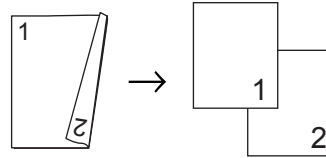

Landscape

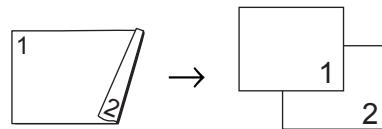

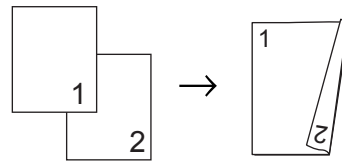

■ **Advanced 1 sided - 2 sided**

Portrait

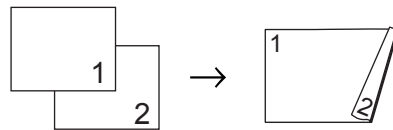

Landscape



- 1 Make sure you are in Copy mode .
- 2 Load your document.
- 3 Use the dial pad to enter the number of copies (up to 99).
- 4 Press **Duplex** and ▲ or ▼ to select **Advanced**.

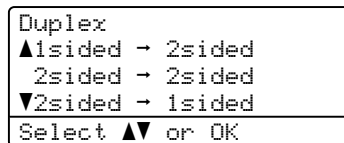

Press **OK**.

- 5 Press ▲ or ▼ to select
2sided → 1sided or
1sided → 2sided.
Press **OK**.

```
Duplex Advanced
▲2sided → 1sided
▼1sided → 2sided
Select ▲▼ or OK
```

- 6 Press **Black Start** or **Color Start** to scan the document.



Note

Duplex copy using a 2-sided legal size document is not available.

Sorting copies using the ADF

You can sort multiple copies. Pages will be stacked in the order 1 2 3, 1 2 3, 1 2 3, and so on.

- 1 Make sure you are in Copy mode .
- 2 Load your document in the ADF.
- 3 Use the dial pad to enter the number of copies (up to 99).
- 4 Press **Sort**.
- 5 Press **Black Start** or **Color Start**.

Adjusting brightness, contrast and color

Brightness

Adjust the copy brightness to make copies darker or lighter.

To *temporarily* change the copy brightness setting, follow the steps below:

- 1 Make sure you are in Copy mode .
- 2 Load your document.
- 3 Use the dial pad to enter the number of copies (up to 99).
- 4 Press ▲ or ▼ to choose **Bright**.

```
Quality :Auto
Enlg/Red:100%
Tray    :MP>T1
Bright  :-□□■□□+▶
Select ◀▶ & OK
```

- 5 Press ▶ to make a lighter copy or press ◀ to make a darker copy.
Press **OK**.
- 6 Press **Black Start** or **Color Start**.

To change the *default* setting follow the steps below:

- 1 Press **Menu**, 3, 2.

```
32.Brightness
      -□□■□□+
Select ◀▶ & OK
```

- 2 Press ▶ to make a lighter copy or press ◀ to make a darker copy.
Press **OK**.
- 3 Press **Stop/Exit**.

Contrast

Adjust the contrast to help an image look sharper and more vivid.

To *temporarily* change the contrast setting, follow the steps below:

- 1 Make sure you are in Copy mode .
- 2 Load your document.
- 3 Use the dial pad to enter the number of copies (up to 99).
- 4 Press **Contrast/Quality**.
Press **▲** or **▼** to choose **Contrast**.
Press **OK**.

```

Contrast: -□□■□□+▶
Quality :Auto
Enlg/Red:100%
Tray    :MP>T1
Select ◀ ▶ & OK
  
```

- 5 Press **◀** or **▶** to increase or decrease the contrast.
Press **OK**.
- 6 Press **Black Start** or **Color Start**.

To change the *default* setting follow the steps below:

- 1 Press **Menu, 3, 3**.

```

33.Contrast

      -□□■□□+

Select ◀ ▶ & OK
  
```

- 2 Press **◀** or **▶** to increase or decrease the contrast.
Press **OK**.
- 3 Press **Stop/Exit**.

Color saturation

You can change the default setting for color saturation.

To change the *default* setting follow the steps below:

- 1 Press **Menu, 3, 4**.

```

34.Color Adjust
  1.Red
  2.Green
  3.Blue
Select ▲▼ or OK
  
```

- 2 Press **▲** or **▼** to choose 1.Red, 2.Green or 3.Blue.
Press **OK**.
- 3 Press **◀** or **▶** to increase or decrease the color saturation.
Press **OK**.
- 4 Return to 2 to choose the next color. Or press **Stop/Exit**.

Tray selection

You can change the tray use only for the next copy.

- 1 Make sure you are in Copy mode .
- 2 Load your document.
- 3 Use the dial pad to enter the number of copies (up to 99).
- 4 Press **Tray Select**.
- 5 Press ◀ or ▶ to choose the MP>T1, T1>MP, #1 (XXX) ¹ or MP (XXX) ¹. Press **OK**.
- 6 Press **Black Start** or **Color Start**.

Press Tray Select	MP>T1 or M>T1>T2
	T1>MP or T1>T2>M
	#1 (XXX) ¹
	#2 (XXX) ¹
	MP (XXX) ¹

¹ XXX is the paper size you set in **Menu, 1, 3**.



Note

- T2 or #2 appears only if the optional paper tray is installed.
- To change the default setting for Tray Select, see *Tray use in copy mode* on page 23.

Out of memory message

If the memory becomes full while you are making copies, the LCD message will guide you through the next step.

If you get an *Out of Memory* message while scanning a subsequent page, you will have the option to press **Black Start** or **Color Start** to copy the pages scanned so far, or to press **Stop/Exit** to cancel the operation.

To gain extra memory, you can do the following:

- Print the faxes that are in the memory. (See *Printing a fax from the memory* on page 49.)
- You can turn off Fax Storage. (See *Turning off remote fax options* on page 68.)
- Add optional memory (See *Memory board* on page 112.)



Note

When you get an *Out of Memory* message, you may be able to make copies if you first print incoming faxes in the memory to restore the memory to 100%.



Walk-up printing

- Printing photos from a digital camera** 88
- Printing data from a USB flash memory drive** 91



Your Brother machine supports the PictBridge standard, allowing you to connect to and print photos directly from any PictBridge compatible digital camera.

If your camera is using the USB Mass Storage standard, you can also print photos from a digital camera without PictBridge. (See *Connecting a camera as a storage device* on page 90.)

Before using PictBridge

PictBridge requirements

To avoid errors, remember the following points:

- The machine and the digital camera must be connected using a suitable USB cable.
- The image file must be taken with the digital camera you want to connect to the machine.

Using PictBridge

Setting your digital camera

Make sure your camera is in PictBridge mode. The following PictBridge settings may be available from the LCD of your PictBridge compatible camera. Depending on your camera some of these settings may not be available.

- Copies
- Qualities
- Paper size
- Date print
- File name print
- Layout



Note

The names and availability of each setting depends on the specification of your camera.

You can also set the following PictBridge settings by using the control panel.

Menu selections	Options
Paper Size	Letter, A4, B5, A5, B6, A6
Orientation	Portrait, Landscape ¹
Date & Time	Off, On
File Name	Off, On
Print Quality	Normal, Fine

¹ If you choose the paper size Letter, A4 or B5, Portrait will be chosen. If you choose A5, B6 or A6, Landscape will be chosen.

- 1 Press **Menu**, **5**, **3**.

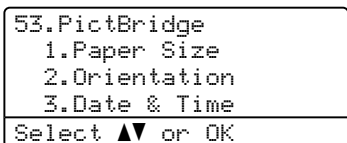

- 2 To set the PictBridge settings, press **▲** or **▼** to choose 1.Paper Size, 2.Orientation, 3.Date & Time, 4.File Name, or 5.Print Quality. Press **OK**.
- 3 Press **▲** or **▼** to choose an option for each menu setting. Press **OK**.
- 4 Press **Stop/Exit**. Repeat 2 to 3 for each PictBridge setting.

Note

- Camera settings are prioritized as long as your camera is not set to use your machine's settings (default settings). If your camera is set to use your machine's settings, the machine will print your photo using the settings below.

Machine settings	Default settings
Paper Size	Letter
Orientation	Portrait
Date & Time	Off
File Name	Off
Print Quality	Normal

- Please refer to the documentation supplied with your camera for more detailed information on changing PictBridge settings.

Printing images

- 1 Make sure that your camera is turned off. Connect your camera to the USB direct interface (1) on the front of the machine using a suitable USB cable.

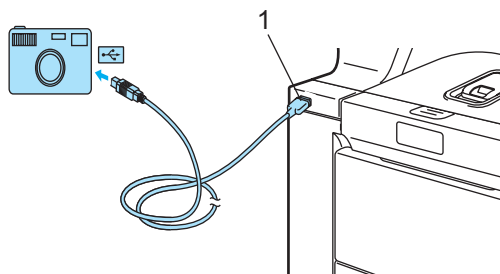

- 2 Turn on the camera. Make sure your camera is in PictBridge mode. When the machine has recognized the camera, the LCD shows the following message depending on which mode the machine is in:

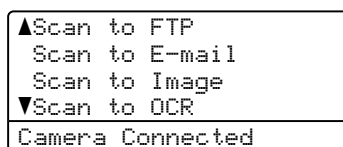
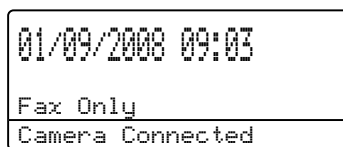

- 3 Set your camera to print an image. Set the number of copies if you are asked.

When the machine starts printing an image, the LCD will show the following message:

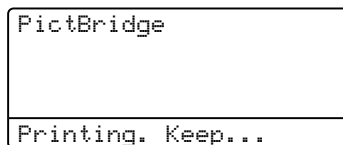

**Note**

Please refer to the documentation supplied with your camera for detailed operations how to print using PictBridge.

CAUTION

To prevent damage to your machine, DO NOT connect any device other than a digital camera or USB flash memory drive to the USB direct interface.

DO NOT remove the digital camera from the USB direct interface until the machine has finished printing.

DPOF printing

DPOF stands for Digital Print Order Format.

Major digital camera manufacturers (Canon Inc., Eastman Kodak Company, Fuji Photo Film Co. Ltd., Matsushita Electric Industrial Co. Ltd. and Sony Corporation) created this standard to make it easier to print images from a digital camera.

If your digital camera supports DPOF printing, you will be able to choose on the digital camera display the images and number of copies you want to print.

The following DPOF settings are available.

- 1 in 1 printing
- Copies

Connecting a camera as a storage device

Even if your camera is not in PictBridge mode, or does not support PictBridge, you can connect your camera as a normal storage device. This enables you to print photos from your camera.

Follow the steps in *Printing data directly from the USB flash memory drive* on page 92.

(If you would like to print photos in PictBridge mode, see *Setting your digital camera* on page 88.)

**Note**

The name of the storage mode and operation differs among digital cameras. Please refer to the documentation supplied with your camera for detailed information, such as how to switch from PictBridge mode to mass storage mode.

Understanding the error messages

Once you are familiar with the types of errors that can occur while you are using the PictBridge, you can easily identify and troubleshoot any problems.

- **Out of Memory**

This message will appear if you are working with images that are too large for the machine's memory.

- **Unusable Device**

This message will appear if you connect an incompatible or broken device to the USB direct interface. To clear the error, unplug the device from the USB direct interface.

(For more detailed solutions, see *Error and maintenance messages* on page 133.)

14

Printing data from a USB flash memory drive

With the direct print feature, you do not need a computer to print data. You can print by just plugging your USB flash memory drive into the machine's USB direct interface.



Note

Some USB flash memory drives may not work with the machine.

Supported file formats

Direct print supports the following file formats:

- PDF version 1.6 ¹
- JPEG
- Exif + JPEG
- PRN (created by MFC-9840CDW driver)
- TIFF (scanned by all MFC or DCP Brother models)
- PostScript® 3™ (created by the MFC-9840CDW BScript3 printer driver)

¹ The data including JBIG2 image file, JPEG2000 image file and layered files are not supported.

Creating a PRN or PostScript® 3™ file for direct printing



Note

The screens in this section may vary depending on your application and operating system.

- 1 From the menu bar of an application, click **File**, then **Print**.
- 2 Choose **Brother MFC-9840CDW Printer** (1) and check the **Print to file** box (2). Click **Print**.

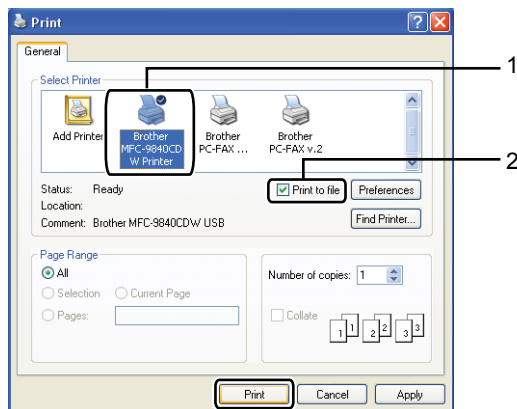

- 3 Choose the folder you want to save the file to and enter the file name if you are prompted to. If you are prompted for a file name only, you can also specify the folder you want to save the file in by entering the directory name. For example:

C:\Temp\FileName.prn

If you have a USB flash memory drive connected to your computer, you can save the file directly to the USB flash memory drive.

Printing data directly from the USB flash memory drive

- 1 Connect your USB flash memory drive to the USB direct interface (1) on the front of the machine.



- 2 When the machine has recognized the USB flash memory drive, the **Direct** LED turns blue. Press the **Direct** key.

```
Direct Print
▲1.FILE0_1.PDF
 2.FILE0_2.PDF
▼3.FILE0_3.PDF
Select ▲▼ or OK
```

- 3 Press ▲ or ▼ to choose the folder name or file name you want to print. Press **OK**.
If you have chosen the folder name, press ▲ or ▼ to choose the file name you want to print. Press **OK**.

Note

- If you want to print an index of the files, choose `Index Print`, and then press **OK**. Press **Black Start** or **Color Start** to print the data.
- File names containing more than 8 characters will appear on the LCD as the first 6 characters of the file name followed by a tilde mark (~) and a number. For example, "HOLIDAY2007.JPG" would appear as "HOLIDA~1.JPG". Only the following characters can be displayed on the LCD:
A B C D E F G H I J K L M N O P Q R S T
U V W X Y Z 0 1 2 3 4 5 6 7 8 9 \$ % ' ` - @
{ } ~ ! # () & _ ^

- 4 Do one of the following:

- Press ▲ or ▼ to choose a setting you need to change and press **OK**, and then press ▲ or ▼ to choose an option for the setting and press **OK**.
- If you do not need to change the current default settings, go to 5.

```
Print File Set
▲Paper Size
  Multiple Page
▼Orientation
Select ▲▼ or OK
```

Note

- You can choose the following settings:
Paper Size
Multiple Page
Orientation
Duplex
Media Type
Collate
Tray Use
Print Quality
PDF Option
- Depending on the file type, some of these settings may not appear.

- 5 Press **Black Start** or **Color Start** if you have finished.
- 6 Press the dial pad key to enter the number of copies you want. Press **OK**.

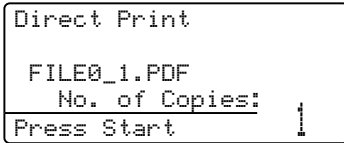

- 7 Press **Black Start** or **Color Start** to print the data.

! CAUTION

To prevent damage to your machine, DO NOT connect any device other than a digital camera or USB flash memory drive to the USB direct interface.

DO NOT remove the USB flash memory drive from the USB direct interface until the machine has finished printing.

Note

- If you want to change the default setting for the paper tray to feed paper from, press **Menu, 1, 7, 3** to change the paper tray setting.
- You can change the default settings for direct print by using the control panel when the machine is not in the direct print mode. Press **Menu, 5** to enter the USB Direct I/F menu. (See *Menu table* on page 204.)

Understanding the error messages

Once you are familiar with the types of errors that can occur while you print data from the USB flash memory drive with direct print, you can easily identify and troubleshoot any problems.

■ **Out of Memory**

This message will appear if you are working with images that are too large for the machine's memory.

■ **Unusable Device**

This message will appear if you connect an incompatible or broken device to the USB direct interface. To clear the error, unplug the device from the USB direct interface.

(See *Error and maintenance messages* on page 133 for the detailed solution.)



Software

Software and network features

96

The User's Guide on the CD-ROM includes the Software User's Guide and Network User's Guide for features available when connected to a computer (for example, printing and scanning). These guides have easy to use links that, when clicked, will take you directly to a particular section.

You can find information on these features:

- Printing
- Scanning
- ControlCenter3 (for Windows®)
- ControlCenter2 (for Macintosh®)
- Remote Setup
- Faxing from your computer
- LDAP
- Network Faxing
- Network Printing
- Network Scanning
- Wireless Network Users



Note

See *Accessing the User's Guides* on page 2.

How to read HTML User's Guide

This is a quick reference for using the HTML User's Guide.

For Windows®



Note

If you have not installed the software, see *Viewing documentation (Windows®)* on page 3.

- 1 From the **Start** menu, point to **Brother**, **MFC-9840CDW** from the programs group, then click **User's Guides in HTML format**.

- 2 Click on the manual you want (**SOFTWARE USER'S GUIDE**, **NETWORK USER'S GUIDE** or **USER'S GUIDE**) from the top menu.

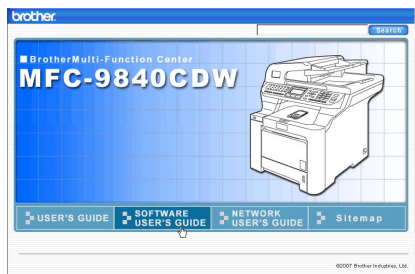

- 3 Click the heading you would like to view from the list at the left of the window.

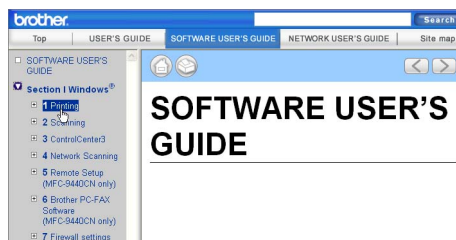

For Macintosh®

- 1 Make sure your Macintosh® is turned on. Insert the Brother CD-ROM into your CD-ROM drive.
- 2 Double-click the **Documentation** icon.
- 3 Double-click your language folder, and then double-click the top page file.
- 4 Click on the manual you want (**SOFTWARE USER'S GUIDE**, **NETWORK USER'S GUIDE** or **USER'S GUIDE**) in the top menu, and then click the heading you would like to read from the list at the left of the window.

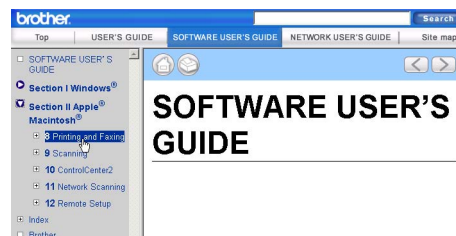



Appendixes

Safety and legal	98
Options	110
Troubleshooting and routine maintenance	114
Menu and features	204
Specifications	224
Glossary	238

A

Safety and legal

Choosing a location

Place your machine on a flat, stable surface that is free of vibration and shocks. Put the machine near a telephone wall jack and a standard, grounded AC power outlet. Choose a location where the temperature remains between 50° F and 90.5° F (10° C and 32.5° C) and the humidity is between 20% to 80% (without condensation).

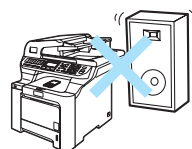
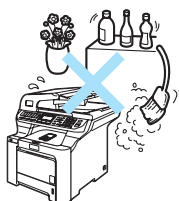
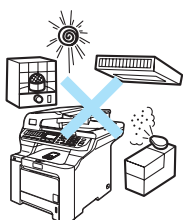

! CAUTION

Avoid placing your machine in a high-traffic area.

DO NOT place the machine near heaters, air conditioners, refrigerators, water, chemicals or devices that contain magnets or generate magnetic fields.

DO NOT expose the machine to direct sunlight, excessive heat, open flames, salty or corrosive gasses, moisture, or dust.

DO NOT connect your machine to an AC power outlet controlled by wall switches or automatic timers.

Disruption of power can wipe out information in the machine's memory.

Avoid interference sources, such as speakers or the base units of non-Brother cordless telephones.

DO NOT put objects on top of the machine.

To use the machine safely

Please keep these instructions for later reference and read them before attempting any maintenance.

WARNING



There are high voltage electrodes inside the machine. Before you clean the inside of the machine, make sure you have unplugged the telephone line cord first and then the power cord from the AC power outlet.

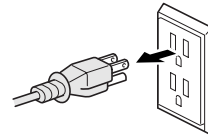

DO NOT handle the plug with wet hands. Doing this might cause an electrical shock.

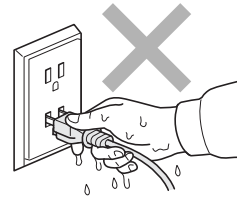

Always make sure the plug is fully inserted.



After you have just used the machine, some internal parts of the machine will be extremely hot. When you open the front or back cover of the machine, DO NOT touch the shaded parts shown in the illustration.

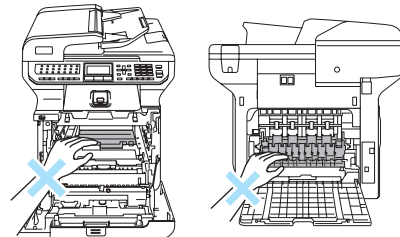

The fuser unit is marked with a caution label. Please DO NOT remove or damage the label.

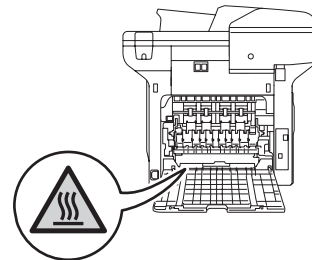



To prevent injuries, be careful not to put your hands on the edge of the machine under the document cover.

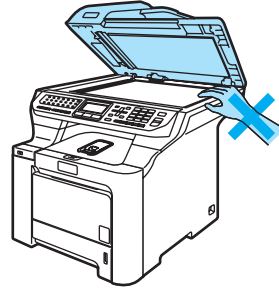

To prevent injuries, be careful not to put your fingers in the area shown in the illustration.

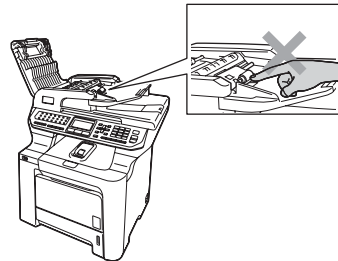

DO NOT use a vacuum cleaner to clean up scattered toner. Doing this might cause the toner dust to ignite inside the vacuum cleaner, potentially starting a fire. Please carefully clean the toner dust with a dry, lint-free cloth and dispose of it according to local regulations.



When you move the machine, grasp the side hand holds that are located at the bottom of the machine. DO NOT carry the machine by holding scanner unit. To prevent injuries when moving or lifting this machine, make sure to use at least two people.

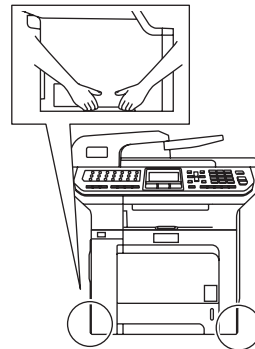

Use caution when installing or modifying telephone lines. Never touch telephone wires or terminals that are not insulated unless the telephone line has been unplugged at the wall jack. Never install telephone wiring during a lightning storm. Never install a telephone wall jack in a wet location.



This product must be installed near an AC power outlet that is easily accessible. In case of an emergency, you must disconnect the power cord from the AC power outlet to shut off the power completely.



To reduce the risk of shock or fire, use only a No. 26 AWG or larger telecommunication line cord.



DO NOT use flammable substances or any type of spray to clean the inside or outside of the machine. Doing this may cause a fire or electrical shock. Refer to *Routine maintenance* on page 152 for how to clean the machine.

**CAUTION**

Lightning and power surges can damage this product! We recommend that you use a quality surge protection device on the AC power line and on the telephone line, or unplug the cords during a lightning storm.

**WARNING****IMPORTANT SAFETY INSTRUCTIONS**

When using your telephone equipment, basic safety precautions should always be followed to reduce the risk of fire, electric shock and injury to people, including the following:

- 1 DO NOT use this product near water, for example, near a bath tub, wash bowl, kitchen sink, washing machine, or in a wet basement or near a swimming pool.
- 2 Avoid using this product during an electrical storm. There may be a remote risk of electric shock from lightning.
- 3 DO NOT use this product to report a gas leak in the vicinity of the leak.
- 4 Use only the power cord provided with the machine.
- 5 DO NOT dispose of batteries in a fire. They may explode. Check with local codes for possible special disposal instructions.

SAVE THESE INSTRUCTIONS

Important information

Standard telephone and FCC notices

These notices are in effect on models sold and used in the United States only.

When programming emergency numbers or making test calls to emergency numbers:

- Remain on the line and briefly explain to the dispatcher the reason for the call before hanging up.
- Perform these activities in the off-peak hours, such as early morning or late evening.

This equipment complies with Part 68 of the FCC rules and the requirements adopted by the ACTA. On the backside of this equipment is a label that contains, among other information, a product identifier in the format US: AAAEQ##TXXXX. If requested, this number must be provided to the telephone company.

You may safely connect this equipment to the telephone line by means of a standard modular jack, USOC RJ11C.

A plug and jack used to connect this equipment to the premises wiring and telephone network must comply with the applicable FCC Part 68 rules and requirements adopted by the ACTA. A compliant telephone cord and modular plug is provided with this product. It is designed to be connected to a compatible modular jack that is also compliant. (See installation instructions for details.)

The REN is used to determine the number of devices that may be connected to a telephone line. Excessive RENs on a telephone line may result in the devices not ringing in response to an incoming call. In most but not all areas, the sum of RENs should not exceed five (5.0). To be certain of the number of devices that may be connected to a line, as determined by the total RENs, contact the local telephone company. For products approved after July 23, 2001, the REN for this product is part of the product identifier that has the format US:AAAEQ##TXXXX. The digits represented by ## are the REN without a decimal point (e.g., 06 is a REN of 0.6). For earlier products, the REN is separately shown on the label.

If this equipment causes harm to the telephone network, the telephone company will notify you in advance that temporary discontinuance of service may be required. But if advance notice isn't practical, the telephone company will notify the customer as soon as possible. Also, you will be advised of your right to file a complaint with the FCC if you believe it is necessary.

The telephone company may make changes in its facilities, equipment, operations or procedures that could affect the operation of the equipment. If this happens the telephone company will provide advance notice in order for you to make necessary modifications to maintain uninterrupted service.

If trouble is experienced with this equipment, for repair or warranty information, please contact Brother Customer Service. (See *Brother numbers* on page i.) If the equipment is causing harm to the telephone network, the telephone company may request that you disconnect the equipment until the problem is resolved.

Connection to party line service is subject to state tariffs. Contact the state public utility commission, public service commission or corporation commission for information.

If your home has specially wired alarm equipment connected to the telephone line, ensure the installation of this equipment does not disable your alarm equipment. If you have questions about what will disable alarm equipment, call your telephone company or a qualified installer.

If you are not able to solve a problem with your machine, call Brother Customer Service. (See *Brother numbers* on page i.)

**WARNING**

For protection against the risk of electrical shock, always disconnect all cables from the wall outlet before servicing, modifying or installing the equipment.

This equipment may not be used on coin service lines provided by the telephone company or connected to party lines.

Brother cannot accept any financial or other responsibilities that may be the result of your use of this information, including direct, special or consequential damages. There are no warranties extended or granted by this document.

This machine has been certified to comply with FCC standards, which are applied to the USA only. A grounded plug should be plugged into a grounded AC power outlet after checking the rating of the local power supply for the machine to operate properly and safely.

Federal Communications Commission (FCC) Declaration of Conformity (USA only)

Responsible Party: Brother International Corporation
100 Somerset Corporate Boulevard
Bridgewater, NJ 08807-0911 USA
TEL: (908) 704-1700

declares, that the products

Product Name: MFC-9840CDW

comply with Part 15 of the FCC Rules. Operation is subject to the following two conditions: (1) This device may not cause harmful interference, and (2) this device must accept any interference received, including interference that may cause undesired operation.

This equipment has been tested and found to comply with the limits for a Class B digital device, pursuant to Part 15 of the FCC Rules. These limits are designed to provide reasonable protection against harmful interference in a residential installation. This equipment generates, uses, and can radiate radio frequency energy and, if not installed and used in accordance with the instructions, may cause harmful interference to radio communications. However, there is no guarantee that interference will not occur in a particular installation. If this equipment does cause harmful interference to radio or television reception, which can be determined by turning the equipment off and on, the user is encouraged to try to correct the interference by one or more of the following measures:

- Reorient or relocate the receiving antenna.
- Increase the separation between the equipment and receiver.
- Connect the equipment into an outlet on a circuit different from that to which the receiver is connected.
- Call the dealer or an experienced radio/TV technician for help.

Important

Changes or modifications not expressly approved by Brother Industries, Ltd. could void the user's authority to operate the equipment.

Important—about the interface cable

A shielded interface cable should be used to ensure compliance with the limits for a Class B digital device.

Industry Canada Compliance Statement (Canada only)

This Class B digital apparatus complies with Canadian ICES-003.

Cet appareil numérique de la classe B est conforme à la norme NMB-003 du Canada.

Disconnect device

This product must be installed near an electrical jack that is easily accessible. In case of emergencies, you must disconnect the power cord from the electrical jack to shut off power completely.

LAN connection

CAUTION

DO NOT connect this product to a LAN connection that is subject to over-voltages.

Laser safety

This equipment is certified as a Class 1 laser product as defined in IEC 60825-1+A2: 2001 under the U.S. Department of Health and Human Services (DHHS) Radiation Performance Standard according to the Radiation Control for Health and Safety Act of 1968. This means that the equipment does not produce hazardous laser radiation.

Since radiation emitted inside the equipment is completely confined within protective housings and external covers, the laser beam cannot escape from the machine during any phase of user operation.

FDA regulations

U.S. Food and Drug Administration (FDA) has implemented regulations for laser products manufactured on and after August 2, 1976. Compliance is mandatory for products marketed in the United States. The following label on the back of the machine indicates compliance with the FDA regulations and must be attached to laser products marketed in the United States.

Manufactured:

BROTHER TECHNOLOGY (SHENZHEN) LTD.

NO6 Gold Garden Ind., Nanling Buji, Longgang, Shenzhen, China.

This product complies with FDA performance standards for laser products except for deviations pursuant to Laser Notice No. 50, dated July 26, 2001.



WARNING

Use of controls, adjustments or performance of procedures other than those specified in this manual may result in hazardous invisible radiation exposure.

Internal laser radiation

Max. Radiation Power: 30 mW

Wave Length: 780 – 800 nm

Laser Class: Class 3B

Important safety instructions

- 1 Read all of these instructions.
- 2 Save them for later reference.
- 3 Follow all warnings and instructions marked on the product.
- 4 Unplug this product from the wall outlet before cleaning inside of the machine. DO NOT use liquid or aerosol cleaners. Use a damp cloth for cleaning.
- 5 DO NOT place this product on an unstable cart, stand, or table. The product may fall, causing serious damage to the product.
- 6 Slots and openings in the cabinet at the back or bottom are provided for ventilation. To ensure reliable operation of the product and to protect it from overheating, these openings must not be blocked or covered. The openings should never be blocked by placing the product on a bed, sofa, rug, or other similar surface. This product should never be placed near or over a radiator or heater. This product should never be placed in a built-in installation unless proper ventilation is provided.
- 7 This product should be connected to an AC power source within the range indicated on the rating label. DO NOT connect it to a DC power source. If you are not sure, contact a qualified electrician.

- 8 This product is equipped with a 3-wire grounded plug. This plug will only fit into a grounded power outlet. This is a safety feature. If you are unable to insert the plug into the outlet, call your electrician to replace your obsolete outlet. **DO NOT** defeat the purpose of the grounded plug.
- 9 Use only the power cord supplied with this machine.
- 10 **DO NOT** allow anything to rest on the power cord. **DO NOT** place this product where people can walk on the cord.
- 11 If an extension cord is used with this product, make sure that the total ampere ratings on the products plugged into the extension cord **DO NOT** exceed the extension cord ampere rating. Also, make sure that the total of all products plugged into the AC power outlet does not exceed 15 amperes (US only).
- 12 **DO NOT** place anything in front of the machine that will block received faxes. **DO NOT** place anything in the path of received faxes.
- 13 Wait until pages have exited the machine before picking them up.
- 14 Never push objects of any kind into this product through cabinet slots, since they may touch dangerous voltage points or short out parts resulting in the risk of fire or electric shock. Never spill liquid of any kind on the product. **DO NOT** attempt to service this product yourself because opening or removing covers may expose you to dangerous voltage points and other risks and may void your warranty. Refer all servicing to a Brother Authorized Service Center. For the location of your nearest Brother Authorized Service Center, please call
In USA: 1-877-BROTHER (1-877-276-8437)
In Canada: 1-877-BROTHER
- 15 Unplug this product from the AC power outlet and refer all servicing to Brother Authorized Service Personnel under the following conditions:
 - When the power cord is damaged or frayed.
 - If liquid has been spilled into the product.
 - If the product has been exposed to rain or water.
 - If the product does not operate normally when the operating instructions are followed. Adjust only those controls that are covered by the operating instructions. Improper adjustment of other controls may result in damage and will often require extensive work by a qualified technician to restore the product to normal operation.
 - If the product has been dropped or the cabinet has been damaged.
 - If the product exhibits a distinct change in performance, indicating a need for service.
- 16 To protect your product against power surges, we recommend the use of a power protection device (Surge Protector).
- 17 To reduce the risk of fire, electric shock and injury to people, note the following:
 - **DO NOT** use this product near appliances that use water, a swimming pool or in a wet basement.
 - **DO NOT** use the machine during an electrical storm (there is the remote possibility of an electrical shock). If you have connected a telephone **DO NOT** use it to report a gas leak in the vicinity of the leak.

Legal limitations for copying

Color reproductions of certain documents are illegal and many result in either criminal or civil liability. This memorandum is intended to be a guide rather than a complete listing of every possible prohibition. In case of doubt, we suggest that you check with counsel as to any particular questionable documents.

The following documents issued by the United States/Canadian Government or any of its Agencies may not be copied:

- Money
- Bonds or other certificates of indebtedness
- Certificates of Deposit
- Internal Revenue Stamps (canceled or uncanceled)
- Selective Service or draft papers
- Passports
- United States/Canadian Postage Stamps (canceled or uncanceled)
- Food Stamps
- Immigration Papers
- Checks or drafts drawn by Governmental agencies
- Identifying badges or insignias

Copyrighted works cannot be copied. Sections of a copyrighted work can be copied for 'fair use'. Multiple copies would indicate improper use.

Works of art should be considered the equivalent of copyrighted works.

Licenses and Certificates of Title to motor vehicles may not be copied under certain state/provincial laws.

Trademarks

The Brother logo is a registered trademark of Brother Industries, Ltd.

Brother is a registered trademark of Brother Industries, Ltd.

Multi-Function Link is a registered trademark of Brother International Corporation.

Microsoft, Windows and Windows Server are registered trademarks of Microsoft Corporation in the U.S. and other countries.

Windows Vista is either a registered trademark or trademark of Microsoft Corporation in the United States and/or other countries.

Macintosh and TrueType are registered trademarks of Apple Inc.

PostScript is a registered trademark and PostScript 3 is a trademark of Adobe Systems Incorporated.

Nuance, the Nuance logo, PaperPort and ScanSoft are trademarks or registered trademarks of Nuance Communications, Inc. or its affiliates in the United States and/or other countries.

Presto! PageManager is a registered trademark of NewSoft Technology Corporation.

PictBridge is a trademark.

BROADCOM, SecureEasySetup and the SecureEasySetup logo are trademarks or registered trademarks of Broadcom Corporation in the United States and/or other countries.

Java and all Java-based trademarks and logos are trademarks or registered trademarks of Sun Microsystems, Inc. in the United States and other countries.

Each company whose software title is mentioned in this manual has a Software License Agreement specific to its proprietary programs.

All other brand and product names mentioned in this User's Guide, the Software User's Guide, and the Network User's Guide are registered trademarks of their respective companies.

B

Options

Options

This machine has the following optional accessories. You can increase the capabilities of the machine with these items.

Lower tray unit

LT-100CL

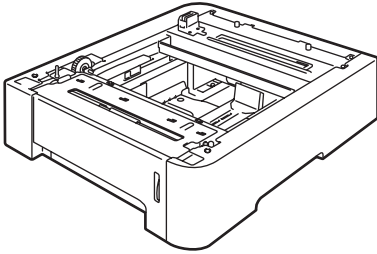

DIMM memory

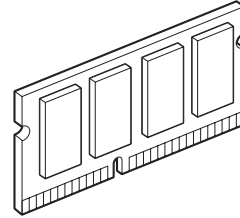

Optional paper tray

Order Number: LT-100CL

An optional lower tray can be installed, and it can hold up to 500 sheets of 20 lb (80 g/m²) paper.

When an optional tray is installed, the machine can hold up to 800 sheets of plain paper.

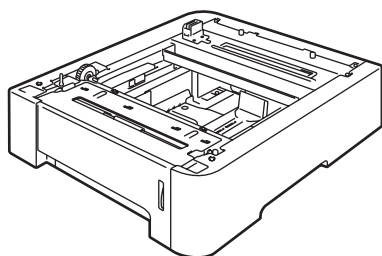

Installing the optional paper tray



WARNING

This machine is heavy. To prevent injuries use at least two people to lift the machine. Be careful not to pinch your fingers when you set the machine down.

- 1 Turn off the power switch. Unplug the telephone line cord and interface cable, and then unplug the power cord from the AC outlet.

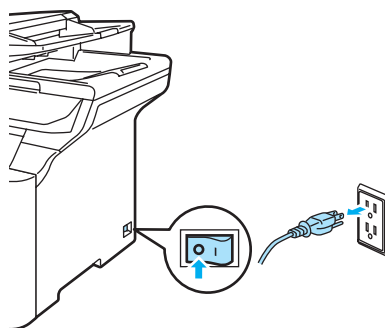

- 2 Using two people, lift the machine carefully and place it onto the optional lower tray unit, so that the alignment pins of the lower tray unit are inserted into the guide holes on the bottom of the machine as shown.

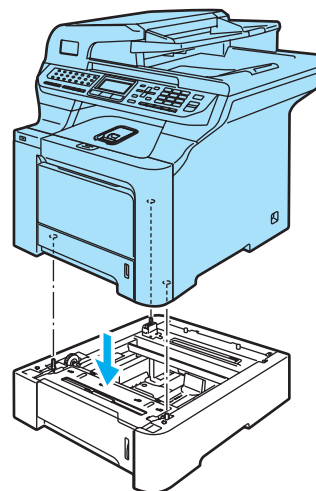

- 3 Plug the machine's power cord back into the AC power outlet first, and reconnect all cables and telephone line cord. Turn on the machine's power switch.
- 4 To set the paper size for the lower tray, press **Menu**, **1**, **3**, **3**. Press **▲** or **▼** to choose A4, Letter, Legal, Executive, A5, B5, B6 or Folio. Press **OK**, and then press **Stop/Exit**.

B

- 5 For Windows® users:
Go to **Start > Control Panel > Printers and Faxes**. Right-click on your printer icon and choose **Properties**. Choose the **Accessories** tab and click **Auto Detect**. When the optional lower tray and paper size have been detected click **Apply**.

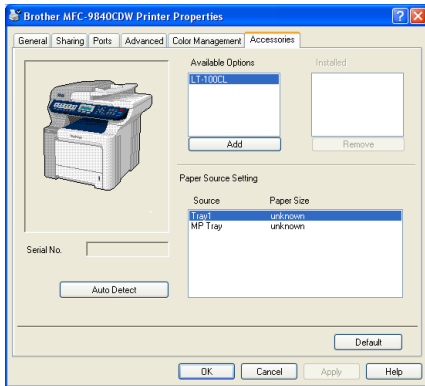

Note

The **Auto Detect** function is not available under the following machine conditions:

- The machine power switch is off.
- The machine is in an error state.
- The machine is in a network shared environment.
- The cable is not connected to the machine correctly.
- If this situation occurs, you can manually add the options you have installed. In **Available Options** select the option you have installed, click **Add**, and then click **Apply**.

For Macintosh® users:

The printer driver is already configured for use with the lower paper tray. No additional steps are required.

Memory board

This machine has 128 MB of standard memory and one slot for optional memory expansion. You can expand the memory up to 640 MB by installing dual in-line memory modules (SO-DIMMs). When you add the optional memory, it increases the performance for both copy and print operations.

In general, the machine uses industry-standard SO-DIMM with the following specifications:

Type: 144 pin and 64 bit output

CAS latency: 2

Clock frequency: 100 MHz or more

Capacity: 64 MB, 128 MB, 256 MB or 512 MB

Height: 1.25 in. (31.75 mm)

Dram Type: SDRAM 2 Bank

You can install the following SO-DIMM:
SDRAM SO-DIMM 144 pin

Capacity: 64 MB, 128 MB, 256 MB or 512 MB

The following web sites sell memory modules:

<http://www.crucial.com/>

<http://www.kingston.com/>

<http://www.goldenram.com/>

<http://www.buffalo-technology.com/>

Note

- There might be some SO-DIMMs that will not work with the machine.
- For more information, call Brother Customer Service.

Installing extra memory

- 1 Turn off the machine's power switch. Unplug the telephone line cord.
- 2 Disconnect the interface cable from the machine, and then unplug the power cord from the AC power outlet.
- 3 Remove the DIMM covers (1 and 2).

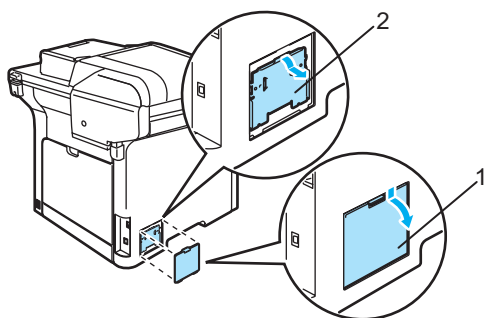

- 4 Unpack the DIMM and hold it by its edges.

! CAUTION

To prevent damage to the machine from static electricity, DO NOT touch the memory chips or the board surface.

- 5 Hold the DIMM by the edges and align the notches in the DIMM with the protrusions in the slot. Insert the DIMM diagonally (1), then tilt it toward the interface board until it clicks into place (2).

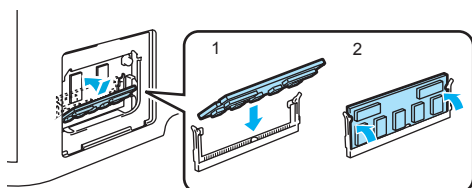

- 6 Put the DIMM covers (2 and 1) back on.

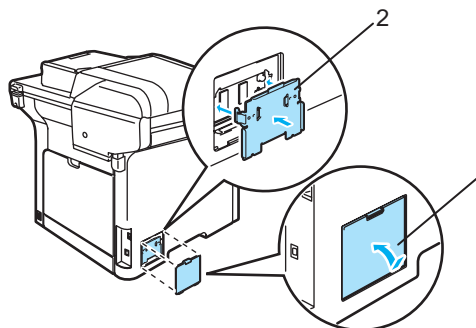

- 7 Plug the machine's power cord back into the AC power outlet first, and then connect the interface cable.
- 8 Plug in the telephone line cord. Turn on the machine's power switch.



Note

To make sure that you have installed the SO-DIMM properly, you can print the user settings page that shows the current memory size. (See *Reports* on page 75.)

C

Troubleshooting and routine maintenance

Troubleshooting

IMPORTANT

For technical help, you must call the country where you bought the machine. Calls must be made **from within** that country.

If you are having difficulty with your machine

If you think there is a problem, check the chart below and follow the troubleshooting tips. You can solve most problems by yourself.

If you need additional help, the Brother Solutions Center offers the latest FAQs and troubleshooting tips.

Visit us at <http://solutions.brother.com>.

Printing or receiving faxes

Difficulties	Suggestions
<ul style="list-style-type: none"> ■ Condensed print ■ Horizontal streaks ■ Top and bottom sentences are cut off ■ Missing lines 	Usually this is caused by a poor telephone connection. If your copy looks good, you probably had a bad connection, with static or interference on the telephone line. Ask the other party to send the fax again.
Poor print quality	See <i>Improving the print quality</i> on page 121.
Vertical black lines when receiving	One of the corona wires for printing may be dirty. Clean the four corona wires. (See <i>Cleaning the corona wires</i> on page 158.)
	The sender's scanner may be dirty. Ask the sender to make a copy to see if the problem is with the sending machine. Try receiving from another fax machine.
	If the problem continues, call Brother Customer Service at 1-877-BROTHER (1-877-276-8437) (in USA) or 1-877-BROTHER (in Canada).
Received faxes appear as split or blank pages.	If the received faxes are divided and printed on two pages or if you get an extra blank page, your paper size setting may not be correct for the paper you are using. (See <i>Paper size</i> on page 23.)
	Turn on auto reduction. (See <i>Printing a reduced incoming fax</i> on page 48.)

Telephone line or connections

Difficulties	Suggestions
Dialing does not work.	Check for a dial tone.
	Change Tone/Pulse setting. (See <i>the Quick Setup Guide</i> .) (Canada only)
	Check all line cord connections.
	Check that the machine is plugged in and switched on.
	Send a manual fax by pressing Hook or by lifting the handset of an external telephone and dialing the number. Wait to hear fax receiving tones before pressing Black Start or Color Start .
The machine does not answer when called.	Make sure the machine is in the correct receive mode for your setup. (See <i>Receiving a fax</i> on page 44.) Check for a dial tone. If possible, call your machine to hear it answer. If there is still no answer, check the telephone line cord connection. If you do not hear ringing when you call your machine, ask your telephone company to check the line.

Sending faxes

Difficulties	Suggestions
Poor sending quality.	Try changing your resolution to Fine or S.Fine . Make a copy to check your machine's scanner operation. If the copy quality is not good, clean the scanner. (See <i>Cleaning the scanner</i> on page 153.)
Transmission Verification Report says 'RESULT:NG'.	There is probably temporary noise or static on the line. Try sending the fax again. If you are sending a PC Fax message and get 'RESULT:NG' on the Transmission Verification Report, your machine may be out of memory. To free up extra memory, you can turn off fax storage (see <i>Turning off remote fax options</i> on page 68), print fax messages in memory (see <i>Printing a fax from the memory</i> on page 49) or cancel a delayed fax or polling job (see <i>Checking and canceling waiting jobs</i> on page 42). If the problem continues, ask the telephone company to check your telephone line. If you often get transmission errors due to possible interference on the telephone line, try changing the Compatibility setting to Basic (for VoIP) . (See <i>Telephone line interference</i> on page 132.)
Vertical black lines when sending.	Black vertical lines on faxes you send are typically caused by dirt or correction fluid on the glass strip. (See <i>Cleaning the scanner</i> on page 153.)

Handling incoming calls

Difficulties	Suggestions
The machine 'Hears' a voice as a CNG Tone.	If Easy Receive is set to on, your machine is more sensitive to sounds. It may mistakenly interpret certain voices or music on the line as a fax machine calling and respond with fax receiving tones. Deactivate the machine by pressing Stop/Exit . Try avoiding this problem by turning Easy Receive to off. (See <i>Easy receive</i> on page 47.)
Sending a Fax Call to the machine.	If you answered on an external or extension telephone, press your Fax Receive Code [default setting is (* 51)]. When your machine answers, hang up.

Handling incoming calls (continued)

Difficulties	Suggestions
Custom features on a single line.	<p>If you have Call Waiting, Call Waiting/Caller ID, Caller ID, RingMaster, Voice Mail, an answering machine, an alarm system or other custom feature on a single telephone line with your machine, it may create a problem sending or receiving faxes.</p> <p>For Example: If you subscribe to Call Waiting or some other custom service and its signal comes through the line while your machine is sending or receiving a fax, the signal can temporarily interrupt or disrupt the faxes. Brother's ECM feature should help overcome this problem. This condition is related to the telephone system industry and is common to all devices that send and receive information on a single, shared line with custom features. If avoiding a slight interruption is crucial to your business, a separate line with no custom features is recommended.</p>

Menu access difficulties

Difficulties	Suggestions
The machine beeps when you try to access the Setup Receive and Setup Send menus.	If the Fax key is not illuminated, press it to turn on Fax mode. The Setup Receive setting (Menu, 2, 1) and Setup Send setting (Menu, 2, 2) are available only when the machine is in Fax mode.

Copy quality difficulties

Difficulties	Suggestions
Vertical black line appears in copies.	Black vertical lines on copies are typically caused by dirt or correction fluid on the glass strip, or one of the corona wires for printing is dirty. (See <i>Cleaning the scanner</i> on page 153 and <i>Cleaning the corona wires</i> on page 158.)

Printing difficulties

Difficulties	Suggestions
No printout.	<ul style="list-style-type: none"> ■ Check that the machine is plugged in and the power switch is turned on. ■ Check that the toner cartridges and drum unit are installed properly. (See <i>Replacing the drum unit</i> on page 177.) ■ Check the interface cable connection on both the machine and your computer. (See <i>the Quick Setup Guide</i>.) ■ Check that the correct printer driver has been installed and chosen. ■ Check to see if the LCD is showing an error message. (See <i>Error and maintenance messages</i> on page 133.) ■ Check that machine is online: <ul style="list-style-type: none"> (For Windows Vista®) Click the Start button, Control Panel, Hardware and Sound, and then Printers. Right-click Brother MFC-9840CDW Printer. Make sure that Use Printer Offline is unchecked. (For Windows® XP and Windows Server® 2003) Click the Start button and select Printers and Faxes. Right-click Brother MFC-9840CDW Printer. Make sure that Use Printer Offline is unchecked. (For Windows® 2000) Click the Start button and select Settings and then Printers. Right-click Brother MFC-9840CDW Printer. Make sure that Use Printer Offline is unchecked.

Printing difficulties (continued)

Difficulties	Suggestions
The machine prints unexpectedly or it prints garbage.	<ul style="list-style-type: none"> ■ Pull out the paper tray and wait until the machine stops printing. Then turn off the machine's power switch and disconnect from the power for several minutes. (The machine can be turned off for up to 4 days without losing faxes stored in the memory.) ■ Check the settings in your application to make sure it is set up to work with your machine.
The machine prints the first couple of pages correctly, then some pages have text missing.	<ul style="list-style-type: none"> ■ Check the settings in your application to make sure that it is set up to work with your machine. ■ Your computer is not recognizing the machine's input buffer's full signal. Make sure that you connected the interface cable correctly. (See <i>the Quick Setup Guide</i>.)
The headers or footers appear when the document displays on the screen but they do not show up when it is printed.	There is an unprintable area on the top and bottom of the page. Adjust the top and bottom margins in your document to allow for this.
The machine does not print on both sides of the paper even though the printer driver setting is Duplex.	Check the paper size setting in the printer driver. You need to select Letter, Legal or Folio.
The machine is not printing or has stopped printing and the machine's Status LED turns yellow.	Press Job Cancel . As the machine cancels the job and clears it from the memory it may produce an incomplete printout.

Scanning difficulties

Difficulties	Suggestions
TWAIN errors appear while scanning.	Make sure that the Brother TWAIN driver is chosen as the primary source. In PaperPort™ 11SE, click File, Scan or Get Photo and choose the Brother TWAIN driver .
Network scanning does not work.	See <i>Network difficulties</i> on page 118.

Software difficulties

Difficulties	Suggestions
Cannot install software or print.	Run the Repair MFL-Pro Suite program on the CD-ROM. This program will repair and reinstall the software.
Cannot perform '2 in 1' or '4 in 1' printing.	Check that the paper size setting in the application and in the printer driver are the same.
The machine does not print from Adobe Illustrator.	Try to reduce the print resolution. (See <i>Advanced tab in the Software User's Guide on the CD-ROM</i> .)

Paper handling difficulties

Difficulties	Suggestions
The machine does not load paper. The LCD shows No Paper or a Paper Jam message.	<ul style="list-style-type: none"> ■ If there is no paper, load a new stack of paper into the paper tray. ■ If there is paper in the paper tray, make sure it is straight. If the paper is curled, you should straighten it. Sometimes it is helpful to remove the paper, turn the stack over and put it back into the paper tray. ■ Reduce the amount of paper in the paper tray, and then try again. ■ Check that the MP tray mode is not chosen in the printer driver. ■ If the LCD shows Paper Jam message and you still have a problem, see <i>Paper jams</i> on page 141.
The machine does not feed paper from the MP tray.	<ul style="list-style-type: none"> ■ Fan the paper well and put it back in the tray firmly. ■ Make sure that MP tray mode is chosen in the printer driver.
How do I print on envelopes?	You can load envelopes from the MP tray. Your application must be set up to print the envelope size you are using. This is usually done in the Page Setup or Document Setup menu of your application. (See your application's manual for more information.)
Which paper can I use?	You can use plain paper, recycled paper, envelopes and labels that are made for laser machines. (For details, see <i>Acceptable paper and other media</i> on page 11.)
There is a paper jam.	(See <i>Paper jams</i> on page 141.)

Print quality difficulties

Difficulties	Suggestions
Printed pages are curled.	<ul style="list-style-type: none"> ■ Low quality thin or thick paper or not printing on the recommended side of the paper could cause this problem. Try turning over the stack of paper in the paper tray. ■ Make sure that you choose the Paper Type that suits the media type you are using. (See <i>Acceptable paper and other media</i> on page 11.)
Printed pages are smeared.	The Paper Type setting may be incorrect for the type of print media you are using, or the print media may be too thick or have a rough surface. (See <i>Acceptable paper and other media</i> on page 11 and <i>Basic tab in the Software User's Guide on the CD-ROM</i> .)
Printouts are too light.	<ul style="list-style-type: none"> ■ If this problem occurs when making copies or printing received faxes, turn Toner Save mode to off in the machine menu settings. (See <i>Toner save</i> on page 26.) ■ Set Toner Save mode to off in the Advanced tab in the printer driver. (See <i>Advanced tab in the Software User's Guide on the CD-ROM</i>.)

Network difficulties

Difficulties	Suggestions
Cannot print over a wired Network.	<p>If you are using a wireless connection or are having Network problems see <i>the Network User's Guide on the CD-ROM</i> for more information.</p> <p>Make sure your machine is powered on and is on-line and in Ready mode. Print the Network Configuration list to see your current Network settings. (See <i>How to print a report</i> on page 75.) Reconnect the LAN cable to the hub to verify that the cable and network connections are good. If possible, try connecting the machine to a different port on your hub using a different cable. If the connections are good, the upper LED of the back panel of the machine will be green.</p>

Network difficulties (continued)

Difficulties	Suggestions
<p>The network scanning feature does not work.</p> <p>The network PC Fax Receive feature does not work.</p> <p>The network printing feature does not work.</p>	<p>(For Windows® only) The firewall setting on your PC may be rejecting the necessary network connection. Follow the instructions below to configure your firewall. If you are using a personal firewall software, see the User's Guide for your software or contact the software manufacturer.</p> <p>For Windows® XP SP2 users:</p> <ol style="list-style-type: none"> 1 Click the Start button, Control Panel, Network and Internet Connections and then Windows Firewall. Make sure that Windows Firewall on the General tab is set to On. 2 Click the Advanced tab and Settings... button of the Network Connection Settings. 3 Click the Add button. 4 To add port 54925 for network scanning, enter the information below: <ol style="list-style-type: none"> 1. In Description of service: Enter any description, for example "Brother Scanner". 2. In Name or IP address (for example 192.168.0.12) of the computer hosting this service on your network: Enter "Localhost". 3. In External Port number for this service: Enter "54925". 4. In Internal Port number for this service: Enter "54925". 5. Make sure UDP is selected. 6. Click OK. 5 Click the Add button. 6 To add port 54926 for network PC Fax, enter the information below: <ol style="list-style-type: none"> 1. In Description of service: Enter any description, for example "Brother PC Fax". 2. In Name or IP address (for example 192.168.0.12) of the computer hosting this service on your network: Enter "Localhost". 3. In External Port number for this service: Enter "54926". 4. In Internal Port number for this service: Enter "54926". 5. Make sure UDP is selected. 6. Click OK. 7 If you still have trouble with your network connection, click the Add button. 8 To add port 137 for network scanning, network printing and network PC Fax receiving, enter the information below: <ol style="list-style-type: none"> 1. In Description of service: - Enter any description, for example "Brother PC Fax receiving" 2. In Name or IP address (for example 192.168.0.12) of the computer hosting this service on your network: Enter "Localhost". 3. In External Port number for this service: Enter "137". 4. In Internal Port number for this service: Enter "137". 5. Make sure UDP is selected. 6. Click OK. 9 Make sure if the new setting is added and is checked, and then click OK.



Network difficulties (continued)

Difficulties	Suggestions
<p>The network scanning feature does not work.</p> <p>The network PC Fax Receive feature does not work.</p> <p>The network printing feature does not work.</p> <p>(continued)</p>	<p>For Windows Vista® users:</p> <ol style="list-style-type: none"> 1 Click the Start button, Control Panel, Network and Internet, Windows Firewall and click Change settings. 2 When the User Account Control screen appears, do the following. <ul style="list-style-type: none"> ■ Users who have administrator rights: Click Continue. ■ For users who do not have administrator rights: Enter the administrator password and click OK. 3 Make sure that Windows Firewall on the General tab is set to On. 4 Click the Exceptions tab. 5 Click the Add port... button. 6 To add port 54925 for network scanning, enter the information below: <ol style="list-style-type: none"> 1. In Name: Enter any description, for example "Brother Scanner". 2. In Port number: Enter "54925". 3. Make sure UDP is selected. Then click OK. 7 Click the Add port... button. 8 To add port 54926 for Network PC Fax, enter the information below: <ol style="list-style-type: none"> 1. In Name: Enter any description, for example "Brother PC Fax". 2. In Port number: Enter "54926". 3. Make sure UDP is selected. Then click OK. 9 Make sure that the new setting is added and is checked, and then click Apply. 10 If you still have trouble with your network connection such as network scanning or printing, check File and Printer Sharing box in the Exceptions tab and then click Apply.
<p>Your computer cannot find your machine.</p>	<p>For Windows® users: The firewall setting on your PC may be rejecting the necessary network connection. For details, see the instruction above.</p> <p>For Macintosh® users: Re-select your machine in the DeviceSelector application located in Macintosh HD/Library/Printers/Brother/Utilities or from the Model pop-up menu of ControlCenter2.</p>



Improving the print quality



If you have a print quality problem, print a test page first (**Menu, 4, 2, 3**). If the printout looks good, the problem is probably not the machine. Check the interface cable or try the machine on another computer.



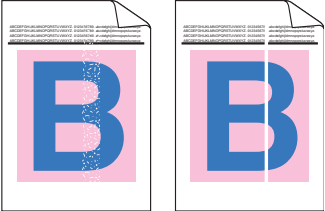

Note

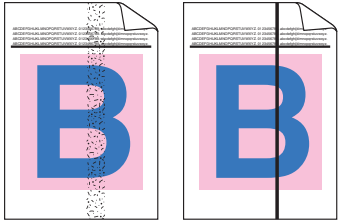
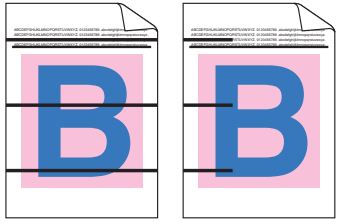
You can resolve a print quality problem by replacing a toner cartridge with a new one when the LCD shows the `Toner Life End` message.

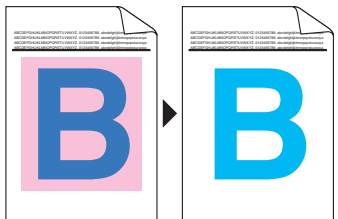
Examples of poor print quality	Recommendation
<p>White lines or bands or ribbing across the page</p> 	<ul style="list-style-type: none"> ■ Make sure that the machine is on a solid level surface. ■ Make sure that the toner cartridges are installed properly. (See <i>Replacing a toner cartridge</i> on page 172.) ■ Shake the toner cartridges gently. ■ Make sure that the drum unit is installed properly. (See <i>Replacing the drum unit</i> on page 177.) ■ Make sure that you use paper that meets our specifications. A rough surfaced paper or thick print media can cause the problem. (See <i>Acceptable paper and other media</i> on page 11.) ■ Clean the laser scanner windows with a soft cloth. (See <i>Cleaning the laser scanner windows</i> on page 154.) ■ The drum unit may be damaged. Put in a new drum unit. (See <i>Replacing the drum unit</i> on page 177.)
<p>Colors are light or unclear on the whole page.</p> 	<ul style="list-style-type: none"> ■ Make sure that the recommended paper was used. ■ Change the paper to freshly unpacked paper. ■ Make sure that the front cover is closed properly. ■ Shake the toner cartridges gently. ■ Clean the laser scanner windows with a soft cloth. (See <i>Cleaning the laser scanner windows</i> on page 154.) ■ Turn off Toner Save. (See <i>Toner save</i> on page 26.)
<p>White streaks or bands down the page</p> 	<ul style="list-style-type: none"> ■ Shake the toner cartridges gently. ■ Clean the laser scanner windows with a soft cloth. (See <i>Cleaning the laser scanner windows</i> on page 154.) ■ One of the toner cartridges may be damaged. Identify the missing color and put in a new toner cartridge. (See <i>Replacing a toner cartridge</i> on page 172.)

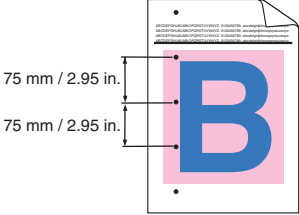
Examples of poor print quality	Recommendation
<p>Colored streaks or bands down the page</p> 	<ul style="list-style-type: none"> ■ One of the toner cartridges may be damaged. Replace the toner cartridge that matches the color of the streak or band. (See <i>Replacing a toner cartridge</i> on page 172.) ■ Clean all four corona wires (one for each color) of the drum unit by sliding the green tab. (See <i>Cleaning the corona wires</i> on page 158.) ■ Make sure each corona wire's green tab is at the home position (▼). ■ The drum unit may be damaged. Put in a new drum unit. (See <i>Replacing the drum unit</i> on page 177.) ■ The fuser unit may have a smudge mark. Call Brother Customer Service at 1-877-BROTHER (1-877-276-8437) (in USA) or 1-877-BROTHER (in Canada).
<p>Colored lines across the page</p> 	<ul style="list-style-type: none"> ■ One of the toner cartridges may be damaged. Replace the toner cartridge that matches the color of the line. (See <i>Replacing a toner cartridge</i> on page 172.) ■ The drum unit may be damaged. Put in a new drum unit. (See <i>Replacing the drum unit</i> on page 177.) ■ Clean all four corona wires (one for each color) of the drum unit by sliding the green tab. (See <i>Cleaning the corona wires</i> on page 158.) ■ Clean the laser scanner windows with a soft cloth. (See <i>Cleaning the laser scanner windows</i> on page 154.)
<p>White spots or hollow print</p> 	<ul style="list-style-type: none"> ■ Make sure that you use paper that meets our specifications. (See <i>Acceptable paper and other media</i> on page 11.) ■ Make sure that the recommended paper was used. ■ Choose Thick paper mode in the printer driver or in the machine's Paper Type menu setting, or use thinner paper than you are currently using. (See <i>Paper type</i> on page 22 and <i>Basic tab in the Software User's Guide on the CD-ROM</i>.) ■ Change the paper to fresh, unopened paper. ■ Check the machine's environment. Conditions such as high humidity can cause hollow print. (See <i>Choosing a location</i> on page 98.) ■ Clean all four corona wires (one for each color) of the drum unit by sliding the green tab. (See <i>Cleaning the corona wires</i> on page 158.) If the print quality has not improved, put in a new drum unit. (See <i>Replacing the drum unit</i> on page 177.) ■ Clean the drum unit. (See <i>Cleaning the drum unit</i> on page 161.)
<p>Completely blank or some colors are missing.</p> 	<ul style="list-style-type: none"> ■ Make sure that the toner cartridges are installed properly. (See <i>Replacing a toner cartridge</i> on page 172.) ■ One of the toner cartridges may be damaged. Identify the missing color and put in a new toner cartridge for the color with the white line. (See <i>Replacing a toner cartridge</i> on page 172.) ■ The drum unit may be damaged. Put in a new drum unit. (See <i>Replacing the drum unit</i> on page 177.)

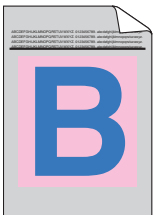
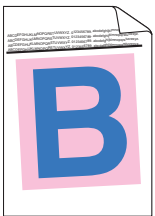
Examples of poor print quality	Recommendation
<p>Colored spots at 2.95 in. (75 mm)</p> 	<ol style="list-style-type: none"> 1 Dust, paper powder, glue, and so on may stick to the surface of the photosensitive drum (OPC) and cause black or white spots to appear on printed documents. 2 Make a few copies of a blank, white sheet of paper. (See <i>Making multiple copies</i> on page 78.) 3 If you still see the spots on printed documents after making multiple copies, clean the drum unit. (See <i>Cleaning the drum unit</i> on page 161.) 4 If the print quality still has not improved you need to install a new drum. (See <i>Replacing the drum unit</i> on page 177.)
<p>Toner scatter or toner stain</p> 	<ul style="list-style-type: none"> ■ Check the machine's environment. Conditions such as high humidity and high temperatures may cause this print quality problem. (See <i>Choosing a location</i> on page 98.) ■ Make sure that you use paper that meets our specifications. Rough-surfaced paper may cause the problem. (See <i>Acceptable paper and other media</i> on page 11.) ■ Install a new toner cartridge for the color causing the problem. (See <i>Replacing a toner cartridge</i> on page 172.) ■ Clean the corona wires and the drum unit for the color causing the problem. (See <i>Cleaning the corona wires</i> on page 158 and <i>Cleaning the drum unit</i> on page 161.) If the print quality has not improved, put in a new drum unit. (See <i>Replacing the drum unit</i> on page 177.)
<p>Gray or colored background</p> 	<ul style="list-style-type: none"> ■ Make sure that you use paper that meets our specifications. (See <i>Acceptable paper and other media</i> on page 11.) ■ Check the machine's environment. Conditions such as high temperatures and high humidity can increase the amount of background shading. (See <i>Choosing a location</i> on page 98.) ■ Install a new toner cartridge for the color causing the problem. (See <i>Replacing a toner cartridge</i> on page 172.) ■ Clean the corona wires of the drum unit for the color causing the problem. (See <i>Cleaning the corona wires</i> on page 158.) If the print quality has not improved, put in a new drum unit. (See <i>Replacing the drum unit</i> on page 177.)
<p>Page skewed</p> 	<ul style="list-style-type: none"> ■ Make sure the paper or other print media is loaded properly in the paper tray and that the guides are not too tight or too loose against the paper stack. ■ Set the paper guides correctly. ■ The paper tray may be too full. ■ Make sure that you use paper that meets our specifications. (See <i>Acceptable paper and other media</i> on page 11.)

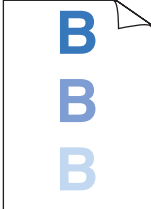
Examples of poor print quality	Recommendation
Ghost 	<ul style="list-style-type: none"> ■ Make sure that you use paper that meets our specifications. Rough-surfaced paper or thick paper may cause the problem. (See <i>Acceptable paper and other media</i> on page 11.) ■ Make sure that you choose the proper media type in the printer driver or in the machine's Paper Type menu setting. (See <i>Acceptable paper and other media</i> on page 11 and <i>Basic tab in the Software User's Guide on the CD-ROM</i>.) ■ The drum unit may be damaged. Put in a new drum unit. (See <i>Replacing the drum unit</i> on page 177.)
The color of your printouts are not what you expected.	<ul style="list-style-type: none"> ■ Make sure that the toner cartridges are installed properly. (See <i>Replacing a toner cartridge</i> on page 172.) ■ Make sure that the toner cartridges are not empty. (See <i>Toner life end message</i> on page 172.) ■ Make sure that the drum unit is installed properly. (See <i>Replacing the drum unit</i> on page 177.) ■ Make sure that the belt unit is installed properly. (See <i>Replacing the belt unit</i> on page 183.) ■ Perform the calibration. Press Menu, 4, 6. (See <i>Software User's Guide on the CD-ROM</i>.) ■ Adjust the color by using the custom setting in the printer driver. Colors the machine can print and colors you see on a monitor are different. The machine may not be able to reproduce the colors on your monitor. ■ Make sure that you use paper that meets our specifications. (See <i>Acceptable paper and other media</i> on page 11.) ■ The drum unit may be damaged. Put in a new drum unit. (See <i>Replacing the drum unit</i> on page 177.) ■ Put in a new belt unit. (See <i>Replacing the belt unit</i> on page 183.)
All one color	<ul style="list-style-type: none"> ■ Clean the corona wires of the drum unit for the color causing the problem. (See <i>Cleaning the corona wires</i> on page 158.) If the print quality has not improved, put in a new drum unit. (See <i>Replacing the drum unit</i> on page 177.) ■ The drum unit may be damaged. Put in a new drum unit. (See <i>Replacing the drum unit</i> on page 177.)

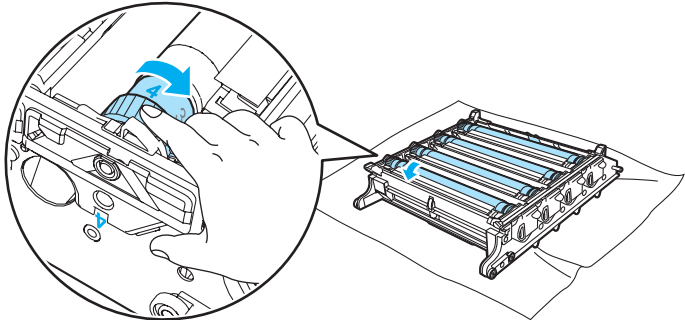
Examples of poor print quality	Recommendation
<p>Color misregistration</p> 	<ul style="list-style-type: none"> ■ Make sure that the drum unit is installed properly. (See <i>Replacing the drum unit</i> on page 177.) ■ Make sure that the belt unit is installed properly. (See <i>Replacing the belt unit</i> on page 183.) ■ Make sure that the waste toner box is installed properly. (See <i>Replacing the waste toner box</i> on page 188.) ■ Perform the auto color registration by using the control panel. Press Menu, 4, 7, 1. <p>Or</p> <ul style="list-style-type: none"> ■ Perform the manual color registration by using the control panel. <ol style="list-style-type: none"> 1 Print the correction chart by using the control panel. Press Menu, 4, 8, 1. 2 Enter the correction value on the chart. Press Menu, 4, 8, 2. <p>If the color misregistration is not corrected after registering the color manually, take all the toner cartridges out of the drum unit and turn the drum unit over, then make sure that four drum unit gears are in the home position. The home position of each drum can be identified by matching the number on the drum unit gear to the same number on the side of the drum unit as shown in the illustration.</p>  <ul style="list-style-type: none"> ■ The drum unit may be damaged. Put in a new drum unit. (See <i>Replacing the drum unit</i> on page 177.) ■ Put in a new belt unit. (See <i>Replacing the belt unit</i> on page 183.) ■ Put in a new waste toner box. (See <i>Replacing the waste toner box</i> on page 188.) ■ If solid area of color or images have cyan, magenta or yellow fringes, you can use the auto registration feature to correct the problem.

C

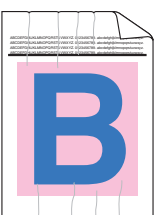
Examples of poor print quality	Recommendation
<p>Uneven density appears periodically across the page</p> 	<ul style="list-style-type: none"> ■ Identify the color that is uneven and put in a new toner cartridge for that color. (See <i>Replacing a toner cartridge</i> on page 172.) ■ The drum unit may be damaged. Put in a new drum unit. (See <i>Replacing the drum unit</i> on page 177.) ■ Make sure that the fuser unit is installed properly.
<p>Missing image at edge</p>	<ul style="list-style-type: none"> ■ Make sure that the toner cartridges are installed properly. (See <i>Replacing a toner cartridge</i> on page 172.) ■ Make sure that the drum unit is installed properly. (See <i>Replacing the drum unit</i> on page 177.) ■ One of the toner cartridges may be damaged. Identify the missing color and put in a new toner cartridge for the color with the white line. (See <i>Replacing a toner cartridge</i> on page 172.) ■ The drum unit may be damaged. Put in a new drum unit. (See <i>Replacing the drum unit</i> on page 177.)
<p>Missing image at thin line</p>	<ul style="list-style-type: none"> ■ If you are using a Windows® printer driver, open Properties window, and then click Printing Preferences. Choose the Advanced tab, Device Options, Print Setting, and then check the Improve pattern printing or Improve Thin Line boxes.
<p>Wrinkle</p> 	<ul style="list-style-type: none"> ■ Change to the recommended type of paper. (See <i>Recommended paper</i> on page 11.) ■ Check the paper type and quality. (See <i>Acceptable paper and other media</i> on page 11.) ■ Make sure that the back cover is closed properly. ■ Make sure that paper is loaded properly. ■ Make sure that you choose the proper media type in the printer driver or in the machine's Paper Type menu setting. (See <i>Acceptable paper and other media</i> on page 11 and <i>Basic tab in the Software User's Guide on the CD-ROM</i>.) ■ Turn over the stack of paper in the tray or rotate the paper 180° in the input tray. ■ Make sure that the drum unit is installed properly. (See <i>Replacing the drum unit</i> on page 177.) ■ Make sure that the fuser unit is installed properly. ■ Replace the fuser unit. Call Brother Customer Service.
<p>Insufficient gloss</p>	<ul style="list-style-type: none"> ■ Change to the recommended type of paper. (See <i>Recommended paper</i> on page 11.)

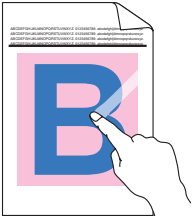
Examples of poor print quality	Recommendation
<p>Offset image</p> 	<ul style="list-style-type: none"> ■ Check the machine's environment. Conditions such as high temperatures and high humidity can cause this problem. (See <i>Choosing a location</i> on page 98.) ■ Make sure that you use paper that meets our specifications. (See <i>Acceptable paper and other media</i> on page 11.) ■ Make sure that you choose the proper media type in the printer driver or in the machine's Paper Type menu setting. (See <i>Acceptable paper and other media</i> on page 11 and <i>Basic tab in the Software User's Guide on the CD-ROM.</i>) ■ Change to the recommended type of paper. (See <i>Recommended paper</i> on page 11.) ■ The drum unit may be damaged. Put in a new drum unit. (See <i>Replacing the drum unit</i> on page 177.)
<p>Poor fixing</p> 	<ul style="list-style-type: none"> ■ Make sure that you use paper that meets our specifications. (See <i>Acceptable paper and other media</i> on page 11.) ■ Make sure that you choose the proper media type in the printer driver or in the machine's Paper Type menu setting. (See <i>Acceptable paper and other media</i> on page 11 and <i>Basic tab in the Software User's Guide on the CD-ROM.</i>) ■ Make sure that the release lever of the fuser unit is in the closed position. ■ Call Brother Customer Service to replace the fuser unit.
<p>Poor fixing when printed on thick paper</p>	<ul style="list-style-type: none"> ■ Choose Thick paper mode in the printer driver or in the machine's Paper Type menu setting. (See <i>Paper type</i> on page 22 and <i>Basic tab in the Software User's Guide on the CD-ROM.</i>) ■ Make sure that you use paper that meets our specifications. (See <i>Acceptable paper and other media</i> on page 11.)

Examples of poor print quality

Recommendation

Curled or wave

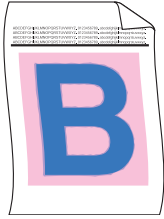

- Make sure that you choose the proper media type in the printer driver or in the machine's Paper Type menu setting. (See *Acceptable paper and other media* on page 11 and *Basic tab in the Software User's Guide on the CD-ROM*.)
- Check the paper type and quality. High temperatures and high humidity will cause paper to curl.
- If you do not use the machine often, the paper may have been in the paper tray too long. Turn over the stack of paper in the paper tray. Also, fan the paper stack and then rotate the paper 180° in the paper tray.
- Follow these steps:
 - 1 Open the back cover.
 - 2 Push the gray lever to the right as shown below.

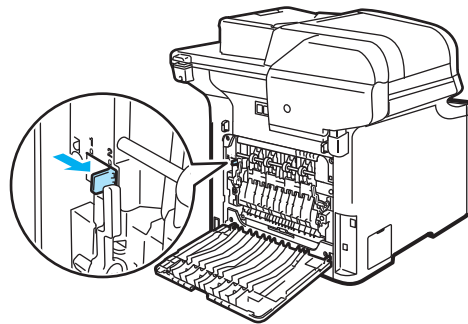

- 3 Close the back cover and re-send the print job.



Note

When you have finished printing, open the back cover and reset the lever back to the original position.

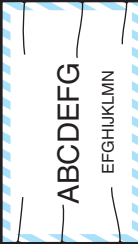
Examples of poor print quality	Recommendation
<p data-bbox="144 299 336 318">Envelope creases</p> 	<ol style="list-style-type: none"> <li data-bbox="500 338 782 376">1 Open the back cover. <li data-bbox="500 396 1248 492">2 Pull down the two gray levers, one on the left-hand side and one on the right-hand side to the envelope position, as shown in the illustration below. <li data-bbox="500 975 1049 1014">3 Close the back cover and re-send the print job. <div data-bbox="528 511 1214 956" style="text-align: center;"> </div> <p data-bbox="500 1043 1255 1149"> Note _____ When you have finished printing, open the back cover and reset the two gray levers back to the original position. </p>

Examples of poor print quality

White lines or ribbing down the page on duplex print



Note

Position B is only for duplex printing with recycled paper when the temperature and humidity are low.

Recommendation

- Choose **Thin Paper** mode in the printer driver and re-send the print job.

If the problem is not solved after printing a few pages, follow these steps:

- 1 Open the back cover.
- 2 Pull down the two grey levers, one on the left-hand side and one on the right-hand side, to position B as shown in the illustration below.

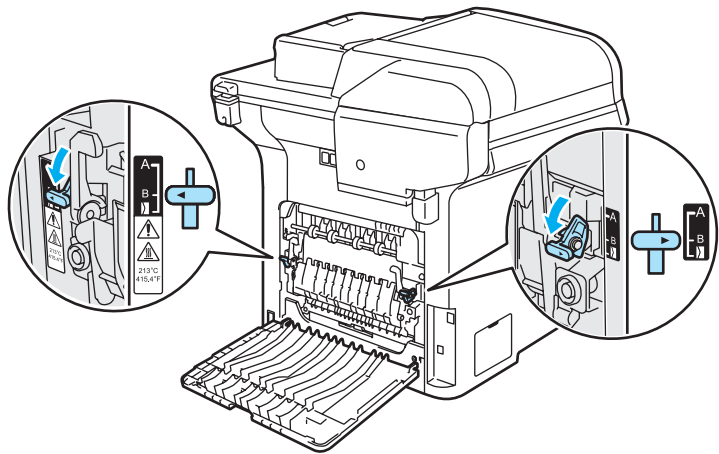

- 3 Close the back cover.
- 4 Choose **Plain Paper** mode in the printer driver and re-send the print job.
- 5 If the problem is not solved after printing a few pages, choose **Thin Paper** mode in the printer driver and re-send the print job.

Note

When you have finished printing, open the back cover and reset the two grey levers back to the original position.

- Use thicker paper than you are now using.

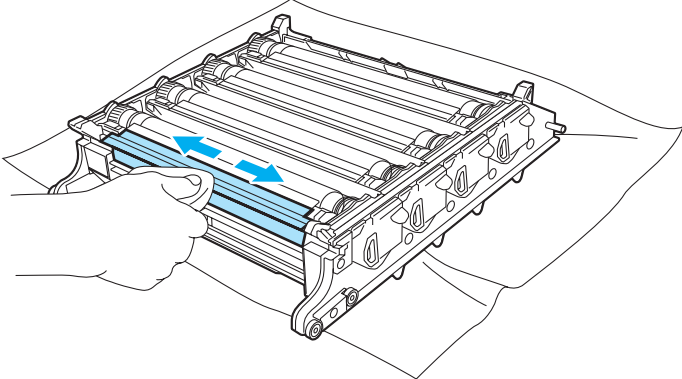
Examples of poor print quality	Recommendation
<p data-bbox="144 299 473 357">Toner scatter or toner stain on the edge of duplex pages</p> 	<div data-bbox="500 299 1255 357" style="background-color: #cccccc; padding: 5px;"> <p>! CAUTION</p> </div> <p data-bbox="514 376 1255 463">We recommend that you place the drum unit and toner cartridges on a clean, flat surface with a piece of disposable paper underneath them in case you accidentally spill or scatter toner.</p> <hr/> <p data-bbox="514 511 1097 540">DO NOT touch the surface of the photosensitive drum.</p> <div data-bbox="500 569 1255 598" style="background-color: #cccccc; height: 15px; margin-top: 10px;"></div> <p data-bbox="528 618 1255 705">Take all the toner cartridges out of the drum unit and turn the drum unit over. Wipe the toner on the edge of drum unit with a dry lint free soft cloth as shown in the illustration.</p> 

Setting dial tone detection

Setting the dial tone to *Detection* will shorten the dial tone detect pause.

- 1 (USA) Press **Menu, 0, 4**.
(Canada) Press **Menu, 0, 5**.

```
04.Dial Tone
▲      Detection
▼      No Detection
Select ▲▼ or OK
```

- 2 Press **▲** or **▼** to choose *Detection* or *No Detection*.
Press **OK**.
- 3 Press **Stop/Exit**.

Telephone line interference

If you are having difficulty sending or receiving a fax due to possible interference on the telephone line, we recommend that you adjust the Equalization for compatibility to reduce the modem speed for fax operations.

- 1 Press **Menu, 2, 0, 1**.

```
20.Miscellaneous
 1.Compatibility
▲      High
▼      Normal
Select ▲▼ or OK
```

- 2 Press **▲** or **▼** to choose *Basic* (for VoIP) or *Normal* (or *High*).

- *Basic* (for VoIP) cuts the modem speed to 9600 bps. and turns the error correction mode (ECM) off.

For a standard telephone line: If you regularly experience interference on your standard telephone line try this setting.

If you are using VoIP: VoIP service providers offer fax support using various standards. If you regularly experience fax transmission errors try this setting.

- *Normal* sets the modem speed at 14400 bps.
- *High* sets the modem speed at 33600 bps.

Press **OK**.

- 3 Press **Stop/Exit**.



Note

When you change the compatibility to *Basic* (for VoIP), the ECM feature is only available for color fax sending.

Error and maintenance messages

As with any sophisticated office product, error and maintenance messages may be displayed. The most common error and maintenance messages are shown below.

Error Message	Cause	Action
Access Error	The device is removed from the USB direct interface while the data is processing.	Press Stop/Exit . Reinsert the device and try to print with direct print or PictBridge.
Calibrate	Calibration failed.	<p>Press Black Start or Color Start and try it again.</p> <p>Do one of the following:</p> <ul style="list-style-type: none"> ■ Turn off the machine's power switch. Wait a few seconds, then turn it on again. ■ Put in a new drum unit. (See <i>Replacing the drum unit</i> on page 177.) ■ Put in a new belt unit. (See <i>Replacing the belt unit</i> on page 183.) ■ Put in a waste toner box. (See <i>Replacing the waste toner box</i> on page 188.) ■ If the problem continues, call Brother Customer Service.
<p>Cartridge Error</p> <p>Put the Black (K) Toner Cartridge back in.¹</p> <p>¹ The toner cartridge color with the problem is shown in the message.</p>	The toner cartridge is not installed properly.	Pull out the drum unit, take out the toner cartridge that is indicated on the LCD, and put it back into the drum unit again.
Change Parts Belt Unit	It is time to replace the belt unit.	Replace the belt unit. (See <i>Replacing the belt unit</i> on page 183.)
Change Parts Drum	The drum unit is near the end of its life.	Use the drum unit until you have a print quality problem; then replace the drum unit with a new one. (See <i>Replacing the drum unit</i> on page 177.)
	The drum unit counter was not reset when a new drum was installed.	Press Menu , 8 , 4 , and then ▲ or ▼ to choose Drum. Press OK and press 1 to reset the drum unit counter.
Change Parts Fuser Unit	It is time to replace the fuser unit.	Call Brother Customer Service to replace the fuser unit.

Error Message	Cause	Action
Change Parts Laser Unit	It is time to replace the laser unit.	Call Brother Customer Service to replace the laser unit.
Change Parts PF Kit MP	It is time to replace the paper feeding kit for the MP tray.	Call Brother Customer Service to replace the PF Kit MP.
Change Parts PF Kit 1	It is time to replace the paper feeding kit for Tray 1.	Call Brother Customer Service to replace the PF Kit 1.
Change Parts PF Kit 2	It is time to replace the paper feeding kit for Tray 2.	Call Brother Customer Service to replace the PF Kit 2.
Change Parts Waste Toner Box	The waste toner box is almost full.	Be ready to replace the waste toner box. (See <i>Replacing the waste toner box</i> on page 188.)
Check Paper Size	The paper in the tray is not the correct size.	Load the correct size of paper in the tray and set the "Paper Size" (Menu, 1, 3) and "Tray Use" (Menu, 1, 7). (See <i>Paper size</i> on page 23, <i>Tray use in copy mode</i> on page 23, <i>Tray use in fax mode</i> on page 24 and <i>Tray use in print mode</i> on page 24.)
Comm.Error	Poor telephone line quality caused a communication error.	Send the fax again or connect the machine to another telephone line. If the problem continues, call the telephone company and ask them to check your telephone line.
Connection Fail	You tried to poll a fax machine that is not in Polled Waiting mode.	Check the other fax machine's polling setup.
Cooling Down Wait for a while	The temperature of the drum unit or toner cartridge is too hot. The machine will pause its current print job and go into cooling down mode. During the cooling down mode, you will hear the cooling fan running while the LCD shows Cooling Down, and Wait for a while.	<p>Make sure that you can hear the fan in the machine spinning and that the exhaust outlet isn't blocked by something.</p> <p>If the fan is spinning, remove any obstacles that surround the exhaust outlet, and then leave the machine turned on but do not use it for several minutes.</p> <p>If the fan is not spinning follow the suggestions below.</p> <p>Turn off the machine's power switch and then turn it on again. If the error message continues leave the machine for several minutes and then try it again. (The machine can be turned off for up to 4 days without losing faxes stored in the memory.)</p>
Cover is Open	The front cover is not closed completely.	Close the front cover of the machine.
Cover is Open	The back cover is not closed completely.	Close the back cover of the machine.
Disconnected	The other person or other person's fax machine stopped the call.	Try to send or receive again.

Error Message	Cause	Action
Document Jam	The document was not inserted or fed properly, or the document scanned from the ADF was too long.	See <i>Document jams</i> on page 140 or <i>Using the ADF (automatic document feeder)</i> on page 20.
DR Mode in Use	The machine is set to Distinctive Ring mode. You cannot change the Receive Mode from Manual to another mode.	Set Distinctive Ring to OFF. (See <i>Turning off distinctive ring</i> on page 53.)
Drum Error	The corona wires on the drum unit needs to be cleaned.	Clean the four corona wires on the drum unit. (See <i>Cleaning the corona wires</i> on page 158.)
EL Error	The machine has a mechanical problem.	Open the front cover and close it again.
Fuser Error	The temperature of fuser unit does not rise at a specified temperature within specified time. The fuser unit is too hot.	Turn the power switch off, wait a few seconds, and then turn it on again. Leave the machine for 15 minutes with the power on. The machine can be turned off for up to 4 days without losing faxes stored in the memory. (See <i>Checking if the machine has faxes in its memory</i> on page 139.)
Init Unable XX	The machine has a mechanical problem.	Turn off the machine's power switch and then turn it on again. If the error message continues leave the machine for several minutes and then try to print, copy or scan again. The machine can be turned off for up to 4 days without losing faxes stored in the memory. (See <i>Checking if the machine has faxes in its memory</i> on page 139.)
Jam Duplex	The paper is jammed in the duplex tray.	(See <i>Paper jams</i> on page 141.)
Jam Rear	The paper is jammed in the back of the machine.	(See <i>Paper jams</i> on page 141.)
Jam Inside	The paper is jammed inside the machine.	(See <i>Paper jams</i> on page 141.)
Jam MP Tray	The paper is jammed in the MP tray of the machine.	(See <i>Paper jams</i> on page 141.)
Jam Tray 1 Jam Tray 2	The paper is jammed in the paper tray of the machine.	(See <i>Paper jams</i> on page 141.)
Low Temperature	The temperature of the machine is too cold.	Increase room temperature to allow the machine to operate.
No Belt Unit	The belt unit is not installed.	Install the belt unit. (See <i>Replacing the belt unit</i> on page 183.)
No Drum Unit	The drum unit is not installed.	Install the drum unit. (See <i>Replacing the drum unit</i> on page 177.)
No Paper	The machine is out of paper or paper is not properly loaded in the paper tray.	Do one of the following: <ul style="list-style-type: none"> ■ Refill the paper in the paper tray or MP tray. ■ Remove the paper and load it again.



Error Message	Cause	Action
No Response/Busy	The number you dialed does not answer or is busy.	Verify the number and try again.
No Tray	The paper tray is not completely closed.	Close the paper tray properly.
No Waste Toner	The waste toner box is not installed.	Install the waste toner box. (See <i>Replacing the waste toner box</i> on page 188.)
Not Registered	You tried to access a One-Touch or Speed Dial number that is not programmed.	Set up the One-Touch or Speed Dial number. (See <i>Storing one-touch dial numbers</i> on page 60 and <i>Storing speed-dial numbers</i> on page 61.)
Out of Memory	The machine's memory is full.	<p>Fax sending or copy operation in progress</p> <p>Do one of the following:</p> <ul style="list-style-type: none"> ■ Press Black Start or Color Start to send or copy the scanned pages. ■ Press Stop/Exit and wait until the other operations in progress finish, and then try again. ■ Clear the data from the memory. (See <i>Out of memory message</i> on page 43 or page 85.) <p>Print operation in process</p> <p>Do one of the following:</p> <ul style="list-style-type: none"> ■ Reduce print resolution. (See <i>Advanced tab in the Software User's Guide on the CD-ROM.</i>) ■ Clear the faxes from the memory. (See <i>Out of memory message</i> on page 85.)
Print Unable XX	The machine has a mechanical problem.	Turn off the machine's power switch and then turn it on again. If the error message continues leave the machine for several minutes and then try to print, copy or scan again. The machine can be turned off for up to 4 days without losing faxes stored in the memory. (See <i>Checking if the machine has faxes in its memory</i> on page 139.)
Protected Device	The protect switch of the USB flash memory drive is on.	Turn off the protect switch of the USB flash memory drive.

Error Message	Cause	Action
Registration	Registration failed.	<p>Press Black Start or Color Start and try again.</p> <p>Do one of the following:</p> <ul style="list-style-type: none"> ■ Try Manual Registration, Menu, 4, 8. (See <i>Manual Registration in the Software User's Guide on the CD-ROM</i>.) ■ Put in a new belt unit. (See <i>Replacing the belt unit</i> on page 183.) ■ Put in a new drum unit. (See <i>Replacing the drum unit</i> on page 177.) ■ Replace the empty toner cartridge with a new one. (See <i>Replacing a toner cartridge</i> on page 172.) ■ Turn off the machine's power switch. Wait a few seconds, then turn it on again. ■ If the problem continues, call Brother Customer Service.
Rename the File	There is already a file on the USB flash memory drive with the same name as the file you are trying to save.	Change the file name of the file on the USB flash memory drive or the file you are trying to save.
Scan Unable XX	The machine has a mechanical problem.	Turn off the machine's power switch and then turn it on again. If the error message continues leave the machine for several minutes before you try it again. The machine can be turned off for up to 4 days without losing faxes stored in the memory. (See <i>Checking if the machine has faxes in its memory</i> on page 139.)
	Document is too long for duplex scanning.	Press Stop/Exit . Use a suitable size of paper for duplex scanning. (See <i>Scan</i> on page 229.)
Scanner Locked	The scanner lock is locked.	<p>Open the document cover, and then release the scanner lock lever.</p> <p>Press Stop/Exit.</p>
<p>Toner Life End</p> <p>Replace Black(K) Toner Cartridge. ¹</p> <p>¹ The toner cartridge color which is used up is shown in the message.</p>	The drum unit and toner cartridges assembly is not installed properly, or one or more of the toner cartridges are used up and printing is not possible.	<p>Do one of the following:</p> <ul style="list-style-type: none"> ■ Re-install the toner cartridges and drum unit assembly. ■ Replace the empty toner cartridge with a new one. (See <i>Replacing a toner cartridge</i> on page 172.) ■ If one of the color toner cartridges is empty, choose Mono in the printer driver to be able to continue printing in monochrome.



Error Message	Cause	Action
Toner Low Prepare New Black(K) Toner Cartridge. ¹ ¹ The toner cartridge color which is near the end of life is shown in the message.	If the LCD shows Toner Low, you can still print; however, the machine is telling you that the toner cartridge is near the end of its life and the toner will soon run out.	Order a new toner cartridge now for the toner cartridge color that is low.
Too Many Files	There are too many files stored on the USB flash memory drive.	Reduce the number of files stored on the USB flash memory drive.
Unusable Device	An incompatible or broken device has been connected to the USB direct interface.	Remove the device from the USB direct interface. Turn off the machine's power switch, wait a few seconds and turn it on again.
Waste Toner Full	It is time to replace the waste toner box.	Replace the waste toner box. (See <i>Replacing the waste toner box</i> on page 188.)
Wrong Paper Size	The paper in the tray is not the correct size or the tray is empty.	Load the correct size of paper in the tray.

Checking if the machine has faxes in its memory

If the LCD shows an error message then you can check to see if there are faxes in the machine's memory.

- 1 Press **Menu, 9, 0, 1**.
- 2 Do one of the following:
 - If the LCD shows `No Data`, there are no faxes left in the machine's memory. Press **Stop/Exit**.
 - If the LCD shows `Dial & Start`, there are faxes in the machine's memory.
 - You can send the faxes to another fax machine. (See *Transferring faxes to another fax machine* on page 139.)
 - You can send the faxes from the machine's memory to your PC. (See *Transferring faxes to your PC* on page 139.)



Note

You can send the Fax Journal report to another fax machine by pressing **Menu, 9, 0, 2** in 1.

Transferring faxes to another fax machine

If you have not set up your Station ID, you cannot enter fax transfer mode.

- 1 Follow 1 and 2 in *Checking if the machine has faxes in its memory* on page 139.
- 2 Enter the fax number to which faxes will be sent.
- 3 Press **Black Start** or **Color Start**.

Transferring faxes to your PC

You can move the faxes from your machine's memory to your PC.

- 1 If you have followed 1 and 2 in *Checking if the machine has faxes in its memory* on page 139, press **Stop/Exit**.
- 2 Make sure that you have installed **MFL-Pro Suite** on your PC, and then turn on **PC-Fax Receiving** on the PC. (For details about PC Fax Receive, see *PC-FAX receiving in the Software User's Guide on the CD-ROM*.)
- 3 Make sure that you have set `PC Fax Receive` on the machine. (See *PC fax receive* on page 67.) During setup the LCD will ask if you want to send the faxes to your PC.
- 4 Do one of the following:
 - To send all faxes to your PC, press **1**.
 - To exit and leave the faxes in the memory, press **2**.
- 5 The LCD will ask you the following message:

```

25.Remote Fax Opt
  Backup Print
▲      Off
▼      On
-----
Select ▲▼ or OK
    
```

Press ▲ or ▼ to choose `On` or `Off`. Press **OK**.

- 6 Press **Stop/Exit**.

Note

- If you choose Backup Print On, the machine will also print the fax at your machine so you will have a copy. This is a safety feature in case there is a power failure before the fax is forwarded or a problem at the receiving machine. The machine can store faxes up to 4 days if there is a power failure.
- If there is an error message on the machine's LCD after the faxes have been sent, disconnect the machine from the power source for several minutes, and then reconnect it.

Document jams

If the document is jammed, follow the steps below.

Document is jammed in the top of the ADF unit

The document may get jammed if it is not inserted or fed properly, or if it is too long. Follow the steps below to clear a document jam.

- 1 Take out any paper from the ADF that is not jammed.
- 2 Open the ADF cover.
- 3 Pull the jammed document out to the left.

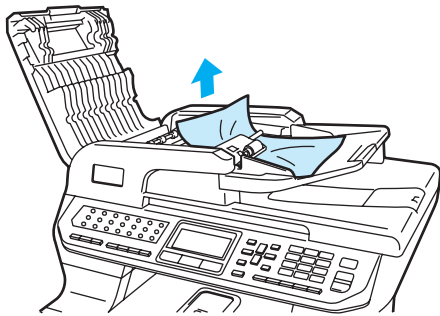

- 4 Close the ADF cover.
- 5 Press **Stop/Exit**.

Document is jammed under the document cover

- 1 Take out any paper from the ADF that is not jammed.
- 2 Lift the document cover.
- 3 Pull the jammed document out to the right.

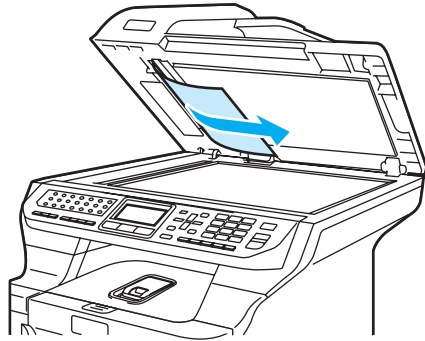

- 4 Close the document cover.
- 5 Press **Stop/Exit**.

Document is jammed at the output tray

- 1 Take out any paper from the ADF that is not jammed.
- 2 Pull the jammed document out to the right.



- 3 Press **Stop/Exit**.

Document is jammed in the duplex slot

- 1 Take out any paper from the ADF that is not jammed.
- 2 Pull the jammed document out to the right.



- 3 Press **Stop/Exit**.

Paper jams

To clear paper jams, please follow the steps in this section.



HOT SURFACE

After you have just used the machine, some internal parts of the machine will be extremely hot. When you open the front or back cover of the machine, **DO NOT** touch the shaded parts shown in the illustration.

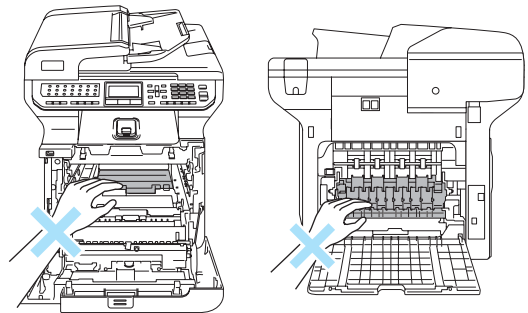

Note

The LCD names for the paper trays are as follows:

- Standard paper tray: Tray 1
- Optional lower tray: Tray 2
- Multi-purpose tray: MP Tray

Paper is jammed in the MP tray

If the LCD shows `Jam MP Tray`, follow these steps:

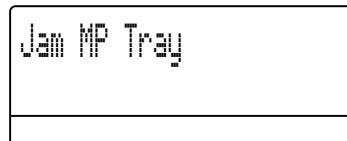

- 1 Remove the paper from the MP tray.
- 2 Remove any jammed paper from in and around the MP tray.

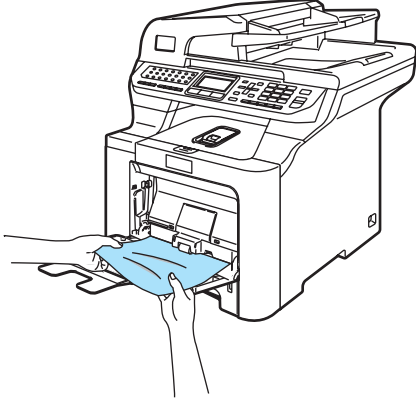

- 3 Close the MP tray. Then open the front cover and close it to reset the machine. Open the MP tray again.
- 4 Fan the paper stack, and then put it back in the MP tray.

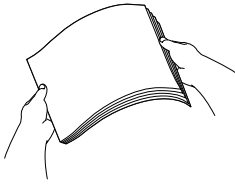

- 5 When loading paper in the MP tray, make sure that the paper stays under the maximum paper height guides on both sides of the tray.

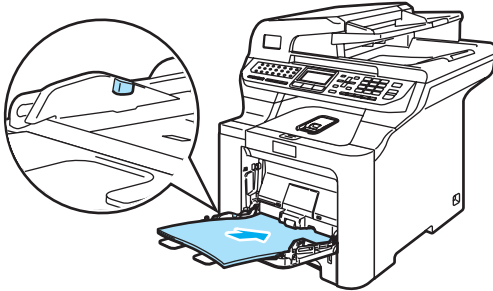

Paper is jammed in Paper Tray 1 or Tray 2

If the LCD shows Jam Tray 1 or Jam Tray 2, follow these steps:

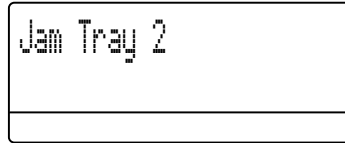
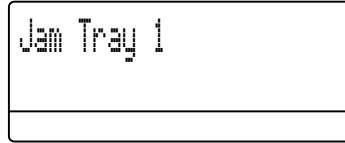

- 1 Pull the paper tray completely out of the machine.

For Jam Tray 1:

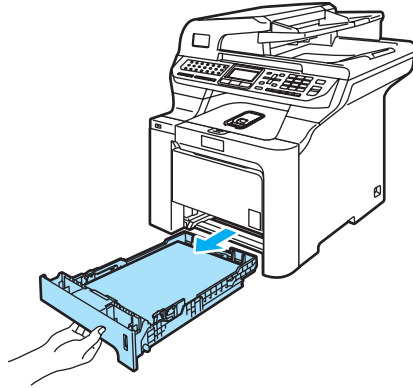

For Jam Tray 2:

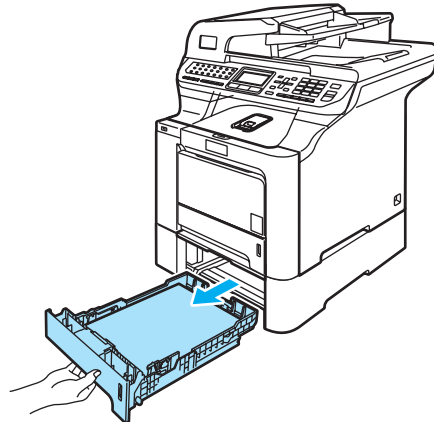

- 2 Use both hands to slowly pull out the jammed paper.

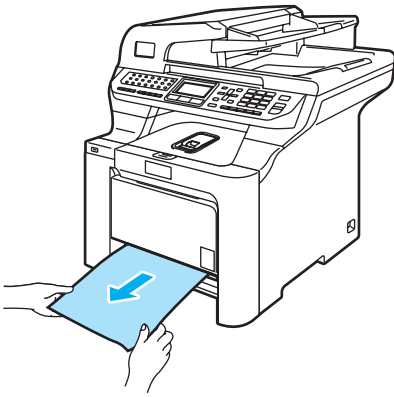

- 3 Make sure the paper is below the maximum paper mark. While pressing the green paper-guide release lever, slide the paper guides to fit the paper size. Make sure that the guides are firmly in the slots.

- 4 Put the paper tray firmly back in the machine.

! CAUTION

DO NOT take out the standard paper tray while paper is feeding from a lower paper tray as this will cause a paper jam.

Paper is jammed inside the machine

If the LCD shows Jam Inside, follow these steps:

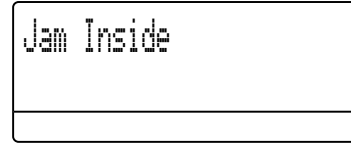

- 1 Pull the paper tray completely out of the machine.

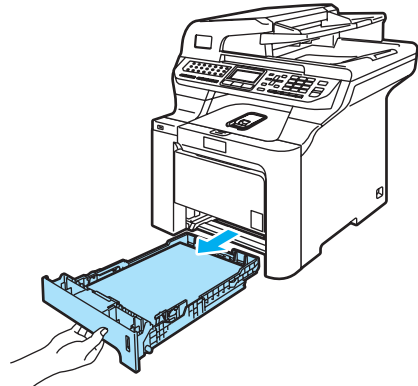

- 2 Use both hands to slowly pull out the jammed paper.

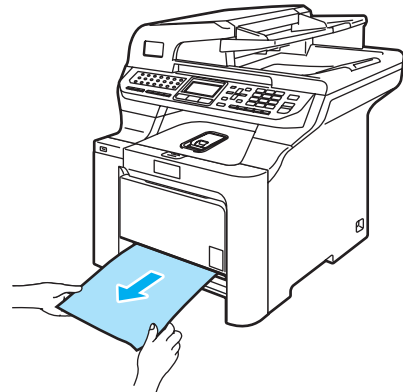

- 3 Press the front cover release button and then open the front cover.

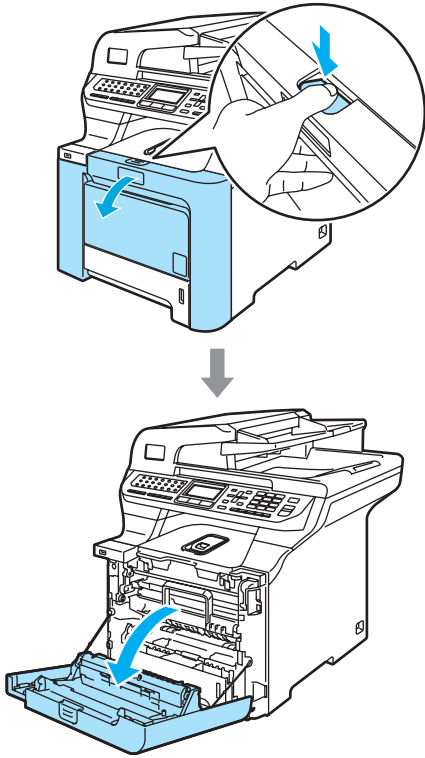

- 4 Hold the green handle of the drum unit. Lift the drum unit up and then pull it out until it stops.

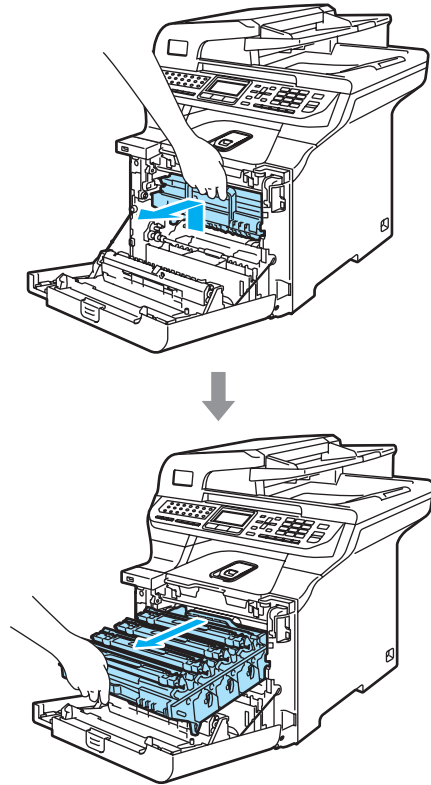

- 5 Release the gray lock lever (1) that is on the left side of the machine. Lift the front of the drum unit up and pull the drum unit completely out of the machine using the green handles on the drum unit.

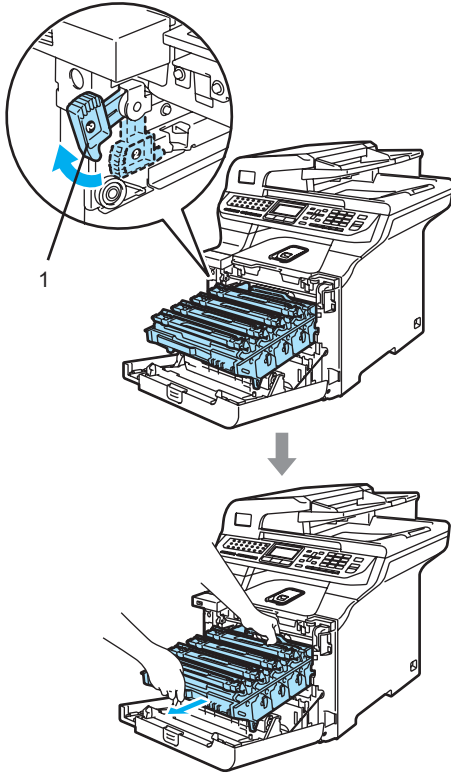

! CAUTION

Hold the handles of drum unit when you carry it. **DO NOT** hold the sides of the drum unit.

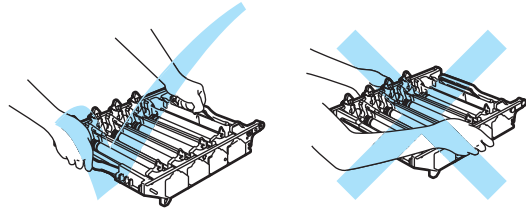

We recommend that you place the drum unit on a clean, flat surface with a piece of disposable paper underneath it in case you accidentally spill or scatter toner.

To prevent damage to the machine from static electricity, **DO NOT** touch the electrodes shown in the illustration.

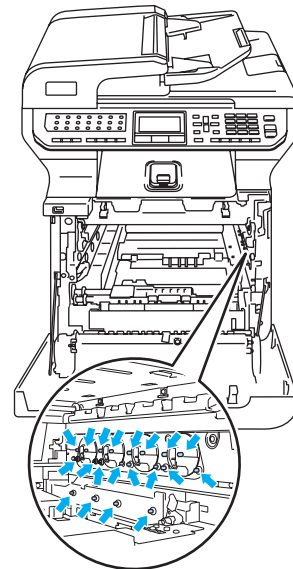

- 6 The jammed paper may be pulled out with the toner cartridge and drum unit assembly, or this may release the paper so you can pull it out of the paper tray opening.

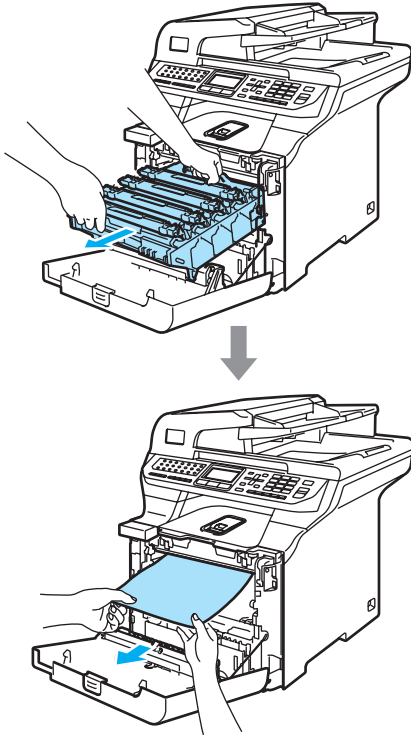

- 7 Put the drum unit back in the machine as follows.

- 1 Make sure that the gray lock lever (1) is in the up position and put the drum unit in the machine. Push down the gray lock lever (1).

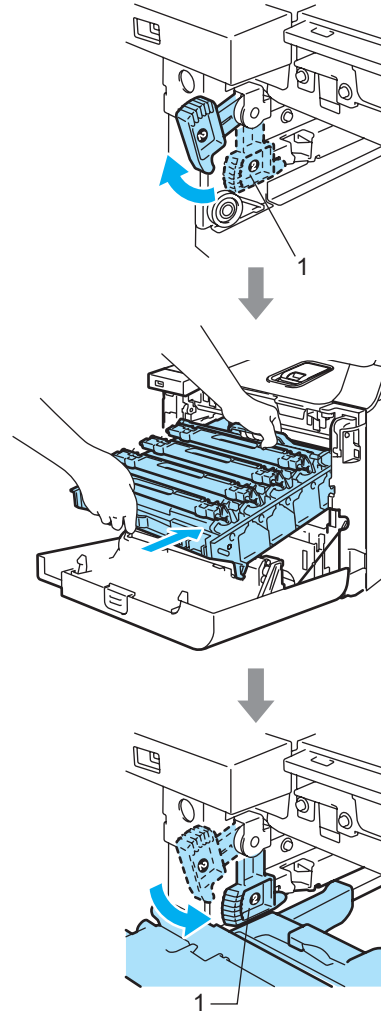



Note

When you put the drum unit in the machine, match the green guides (1) of the drum unit handle to the green arrows (2) on both sides of the machine.

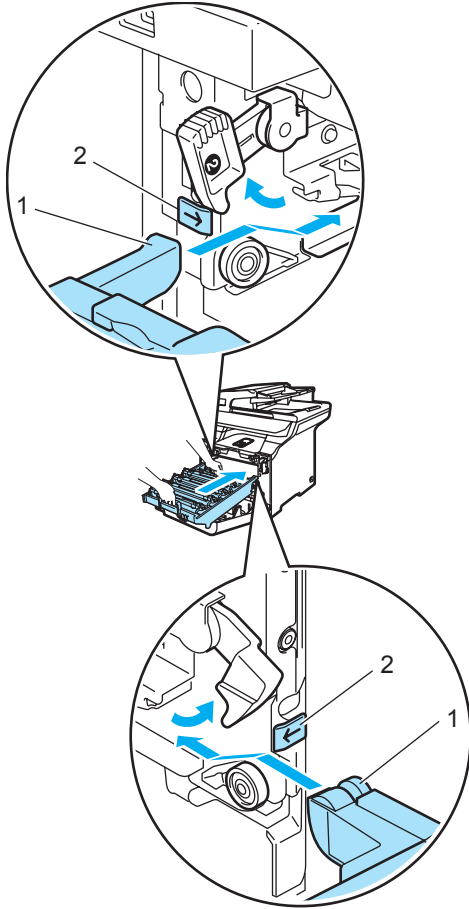

- 2 Push the drum unit in until it stops.

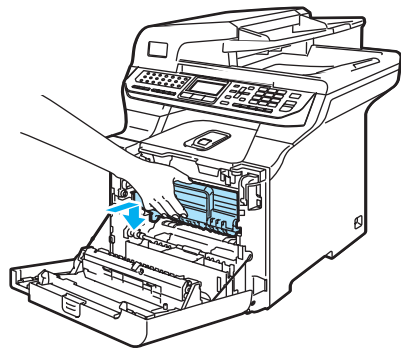
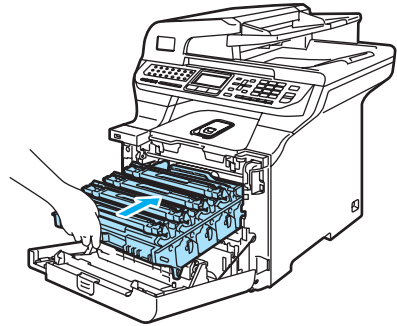

- 8 Close the front cover of the machine.

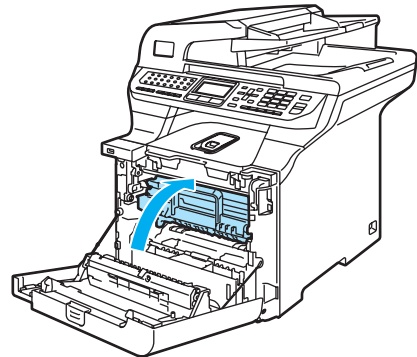

- 9 Put the paper tray firmly back in the machine.

C

Paper is jammed at the back of the machine

If the LCD shows `Jam Rear`, follow these steps:

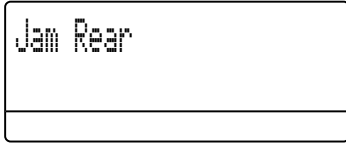

- 1 Press the cover release lever to open the front cover.

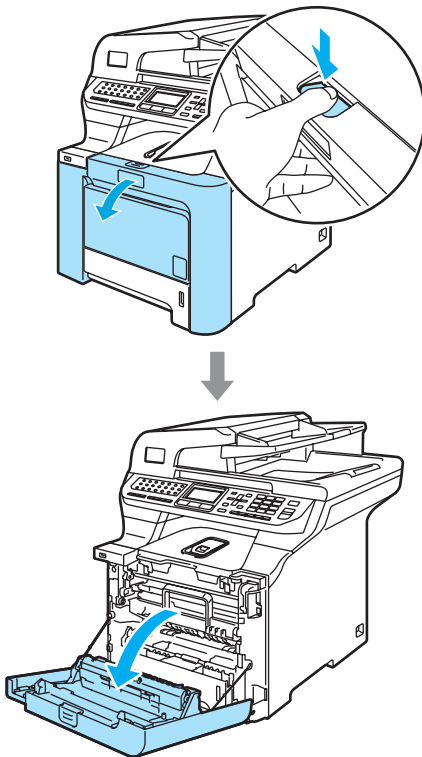

- 2 Hold the green handle of the drum unit. Lift the drum unit up and then pull it out until it stops.

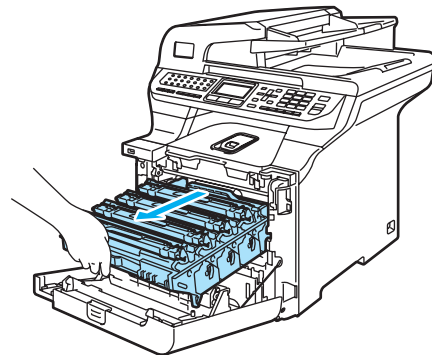
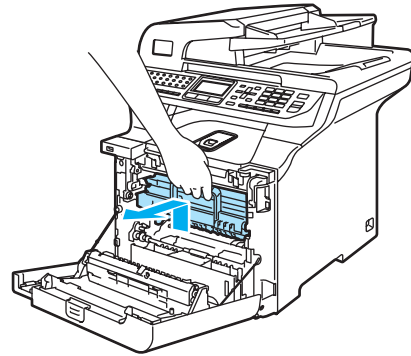

- 3 Open the back cover.

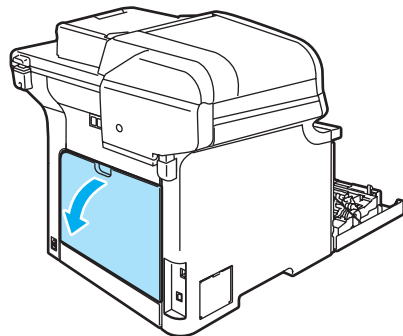

- 4 Pull down the two green levers, one on the left-hand-side and one on the right-hand-side, as shown in the illustration below, and then fold down the fuser cover (1).

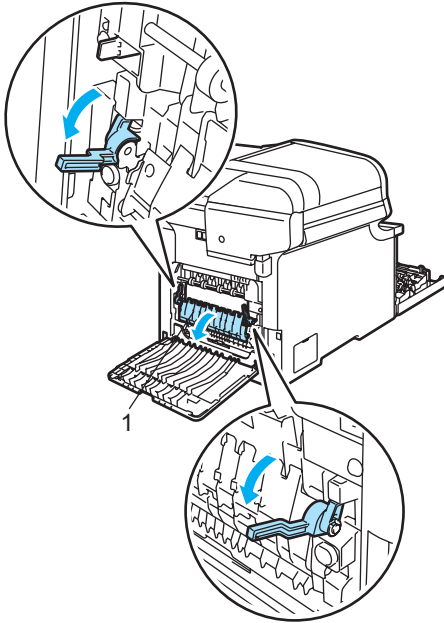

- 5 Using both hands, gently pull the jammed paper out of the fuser unit.

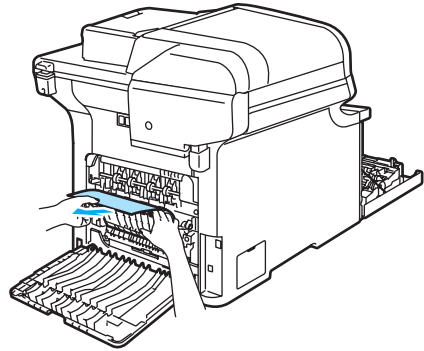

- 6 Close the fuser cover (1) and lift the two green levers at the left and right hand sides.

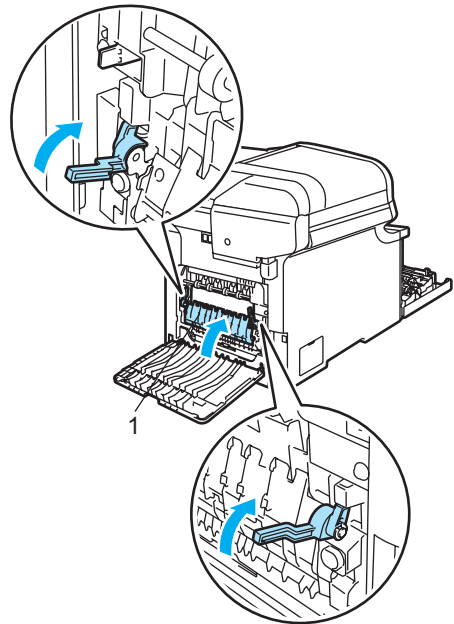

HOT SURFACE

After you have just used the machine, some internal parts of the machine will be extremely hot. When you open the front or back cover of the machine, DO NOT touch the shaded parts shown in the illustration.

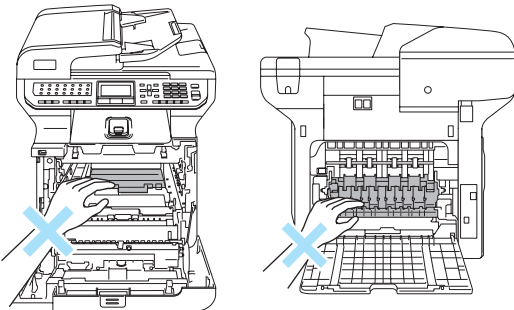

- 7 Close the back cover.

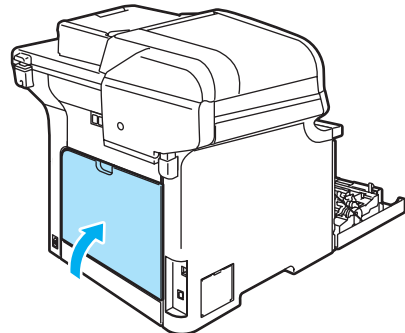

- 8 Put the drum unit and toner cartridge assembly back in the machine.

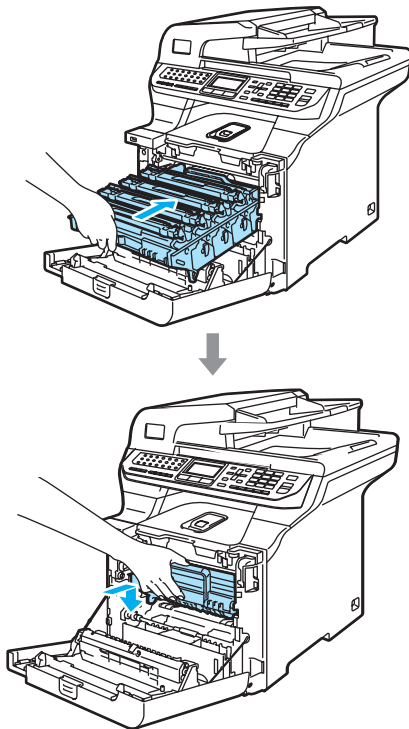

- 9 Close the front cover of the machine.

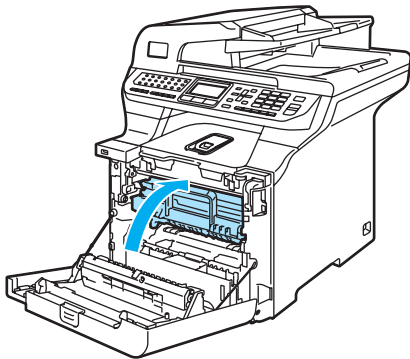

Paper is jammed underneath Paper Tray 1 or in the fuser unit

If the LCD shows Jam Duplex, follow these steps:

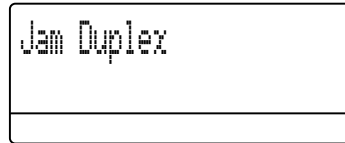

- 1 Pull the paper tray completely out of the machine and check inside the machine.

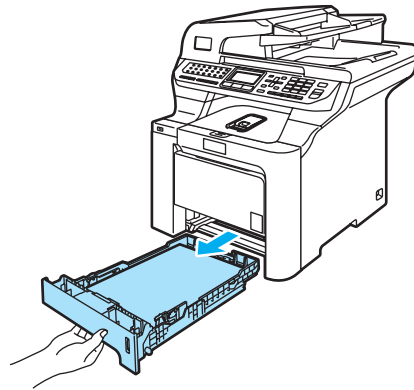

- 2 If paper is not caught inside the machine, check underneath the paper tray.

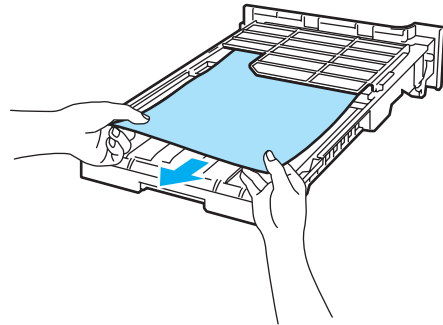

Note

DO NOT put the paper tray back in at this point.

C

- 3 If the paper is not caught in the paper tray, open the back cover.

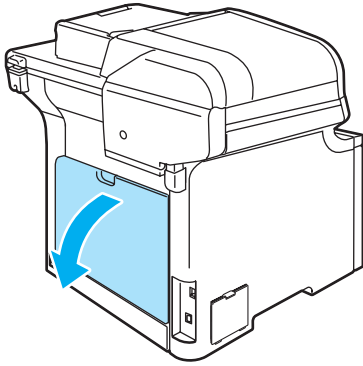

- 4 Push the gray lever on the left hand side (1) to the right.

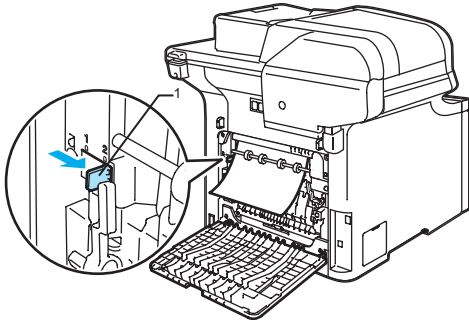

- 5 Pull out the jammed paper slowly.

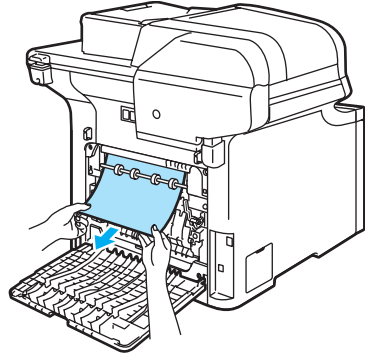

- 6 Reset the gray lever on the left hand side (1) back to the original position.

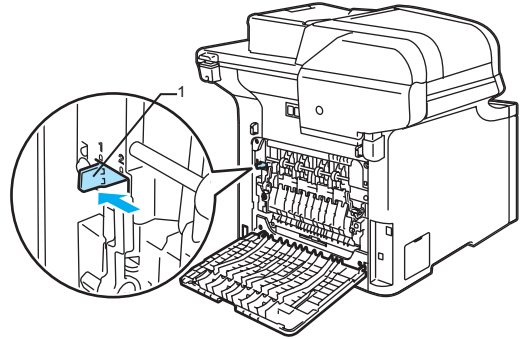

- 7 Close the back cover.

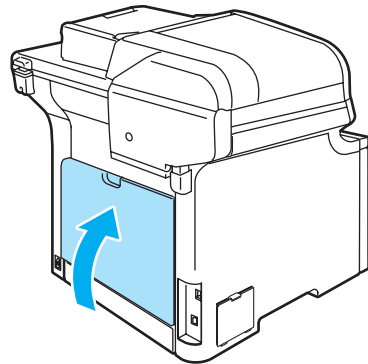

- 8 Put the paper tray firmly back in the machine.

 **HOT SURFACE**

After you have just used the machine, some internal parts of the machine will be extremely hot. When you open the front or back cover of the machine, DO NOT touch the shaded parts shown in the illustration.

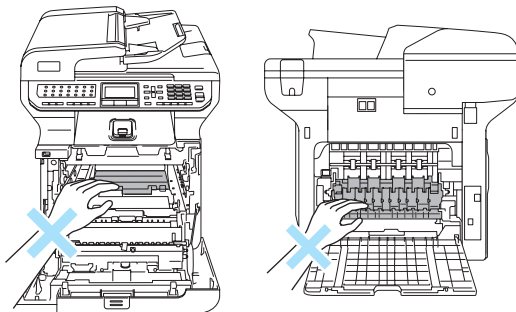

Routine maintenance

! CAUTION

The drum unit contains toner, so handle it carefully. If toner scatters on your hands or clothes, wipe or wash it off with cold water at once.

Cleaning the outside of the machine

! CAUTION

Use neutral detergents. Cleaning with volatile liquids such as thinner or benzine will damage the outside surface of the machine.

DO NOT use cleaning materials that contain ammonia.

DO NOT use isopropyl alcohol to remove dirt from the control panel. It may crack the panel.

DO NOT use flammable substances or any type of spray to clean the inside or outside of the machine. Doing this may cause a fire or electrical shock. For more information, see *Important safety instructions* on page 106.

Clean the outside of the machine as follows:

- 1 Turn off the machine's power switch. Unplug the telephone line cord first, disconnect all cables, and then unplug the power cord from the AC power outlet.
- 2 Pull the paper tray completely out of the machine.

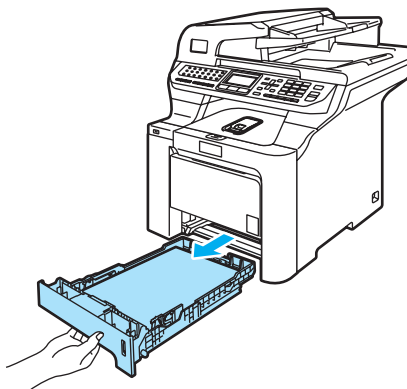

- 3 Wipe the outside of the machine with a dry, lint-free cloth to remove dust.



- 4 Remove anything that is stuck inside the paper tray.

- Wipe the inside of the paper tray with a dry, lint-free cloth to remove dust.

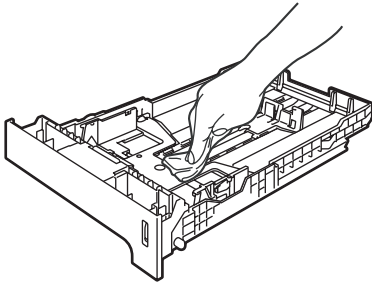

- Re-load the paper and put the paper tray firmly back in the machine.
- Plug the machine's power cord back into the AC power outlet first, and reconnect all cables and telephone line cord. Turn on the machine's power switch.

Cleaning the scanner

- Turn off the machine's power switch. Unplug the telephone line cord first, disconnect all cables, and then unplug the power cord from the AC power outlet.
- Lift the document cover (1). Clean the white plastic surface (2) and scanner glass (3) underneath it with a soft lint-free cloth moistened with a non-flammable glass cleaner.

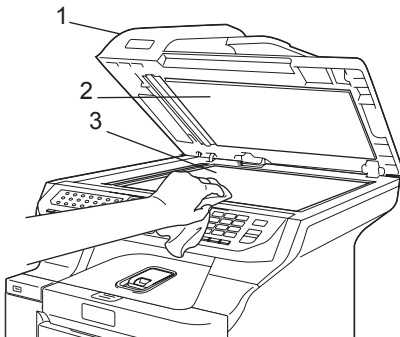

- In the ADF unit, clean the white bar (1) and the scanner glass strip (2) underneath it with a soft lint-free cloth moistened with a non-flammable glass cleaner.

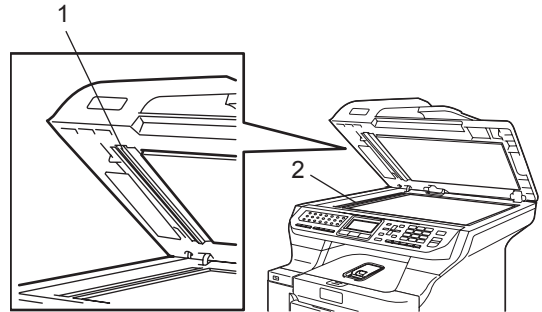

- Plug the machine's power cord back into the AC power outlet first, and reconnect all cables and telephone line cord. Turn on the machine's power switch.



Note

In addition to cleaning the scanner glass and glass strip with a non-flammable glass cleaner, run your finger tip over the glass to see if you can feel anything on it. If you feel dirt or debris, clean the glass again concentrating on that area. You may need to repeat the cleaning process three or four times. To test, make a copy after each cleaning.

Cleaning the laser scanner windows

! CAUTION

DO NOT use isopropyl alcohol to clean the laser scanner windows.

DO NOT touch the laser scanner windows with your fingers.

- 1 Turn off the machine's power switch. Unplug the telephone line cord first, disconnect all cables, and then unplug the power cord from the AC power outlet.
- 2 Press the front cover release button and then open the front cover.

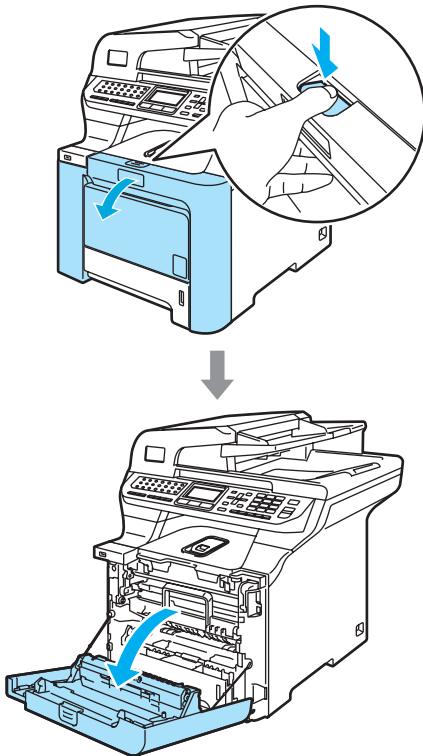

- 3 Hold the green handle of the drum unit. Lift the drum unit up and then pull it out until it stops.

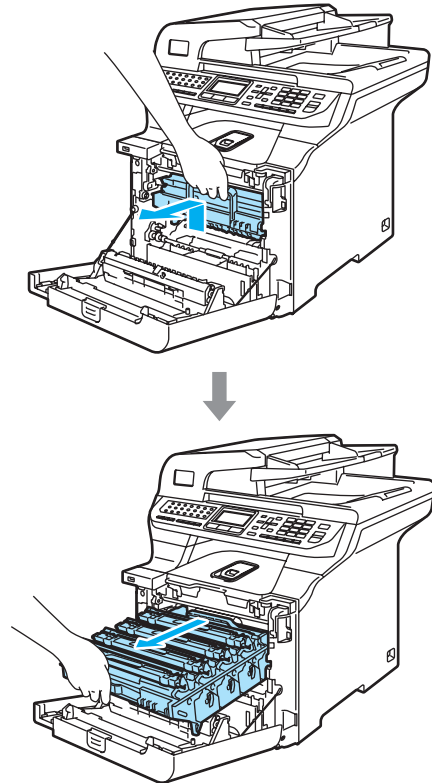

- 4 Release the gray lock lever (1) that is on the left side of the machine. Lift the front of the drum unit and pull the drum unit completely out of the machine using the green handles on the drum unit.

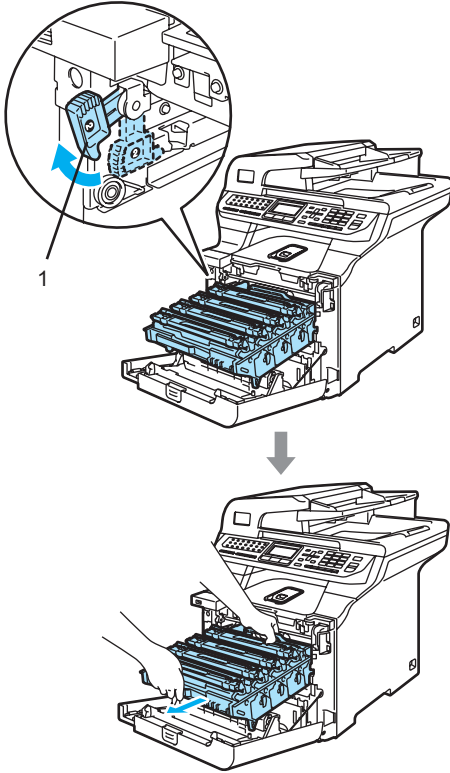

HOT SURFACE

After you have just used the machine, some internal parts of the machine will be extremely hot. When you open the front cover of the machine, DO NOT touch the shaded parts shown in the illustration.

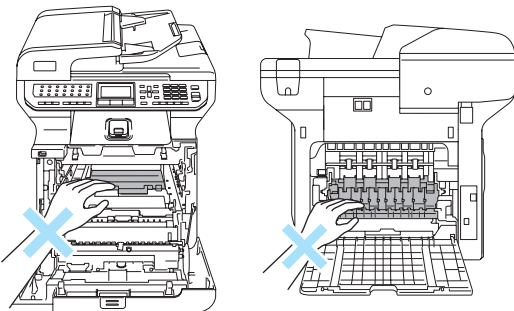

! CAUTION

Hold the handles of drum unit when you carry it. DO NOT hold the sides of the drum unit.

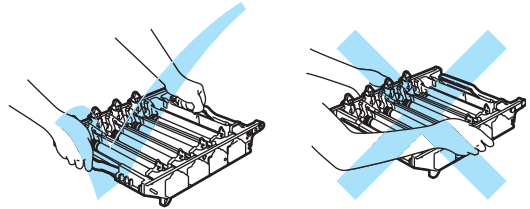

We recommend that you place the drum unit on a clean, flat surface with a piece of disposable paper underneath it in case you accidentally spill or scatter toner.

To prevent damage to the machine from static electricity, DO NOT touch the electrodes shown in the illustration.

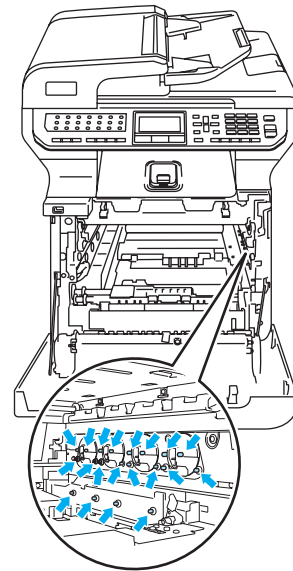

- 5 Wipe the scanner windows (1) with a dry, lint-free cloth.

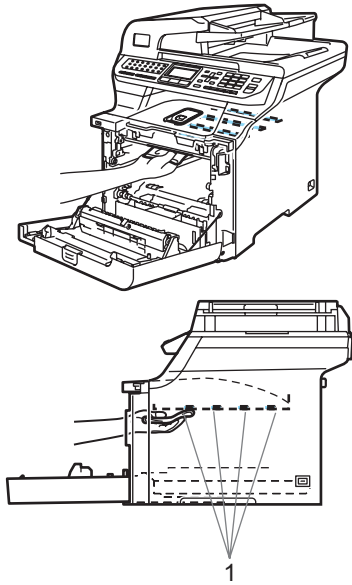

- 6 Put the drum unit back in the machine as follows.

- 1 Make sure that the gray lock lever (1) is in the up position and put the drum unit in the machine. Push down the gray lock lever (1).

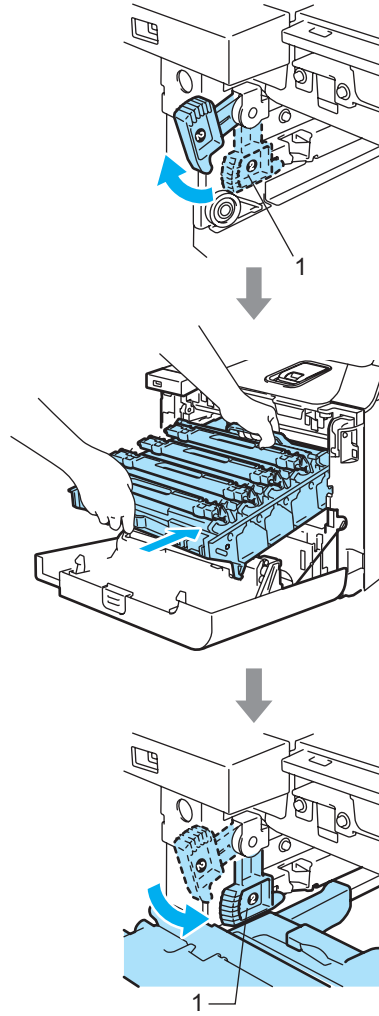



Note

When you put the drum unit in the machine, match the green guides (1) of the drum unit handle to the green arrows (2) on both sides of the machine.

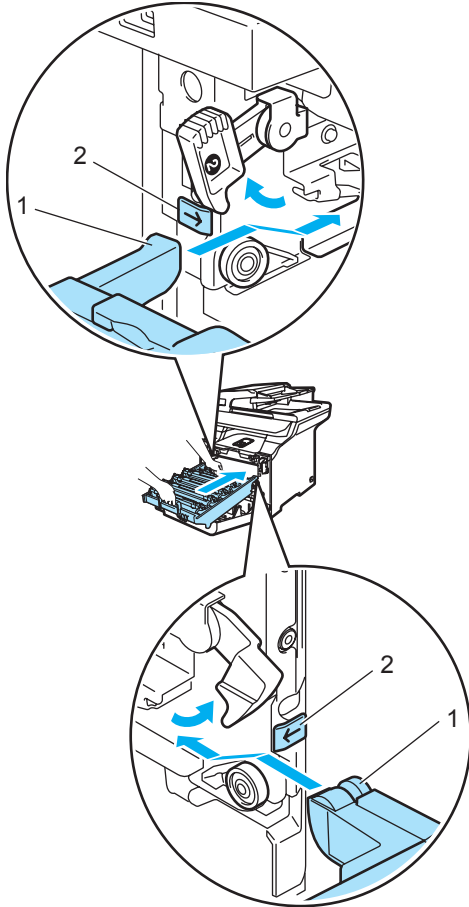

- 2** Push the drum unit in until it stops.

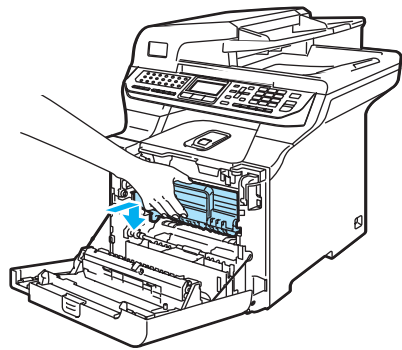
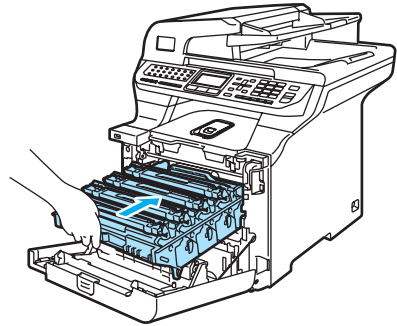

- 7** Close the front cover of the machine.

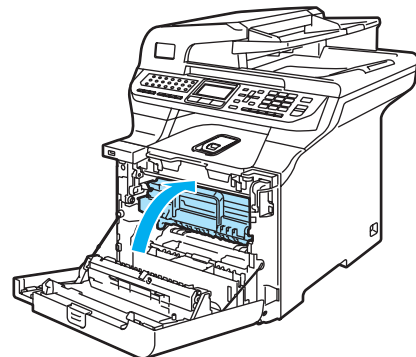

- 8** Plug the machine's power cord back into the AC power outlet first, and reconnect all cables and telephone line cord. Turn on the machine's power switch.

Cleaning the corona wires

If you have print quality problems, clean the corona wires as follows:

- 1 Turn off the machine's power switch. Unplug the telephone line cord first, disconnect all cables, and then unplug the power cord from the AC power outlet.
- 2 Press the front cover release button and then open the front cover.

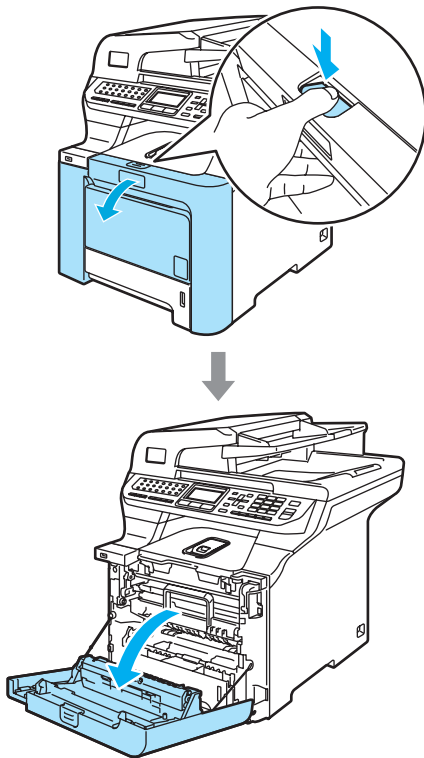

- 3 Hold the green handle of the drum unit. Lift the drum unit up and then pull it out until it stops.

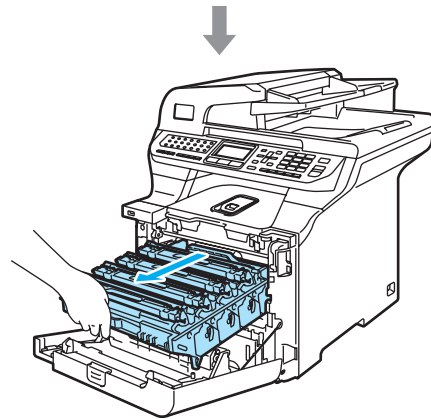
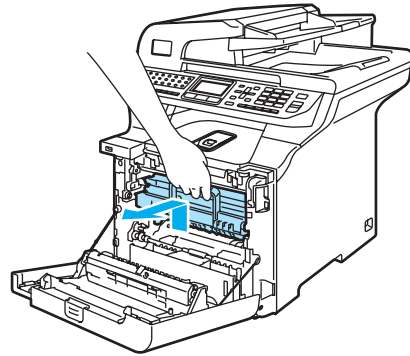

- 4 Hold the handle of the toner cartridge and pull it out of the drum unit. Repeat this for all the toner cartridges.

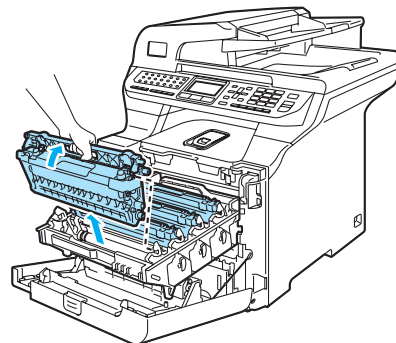

! CAUTION

We recommend that you place the toner cartridges on a clean, flat surface with a piece of disposable paper underneath it in case you accidentally spill or scatter toner.

DO NOT put a toner cartridge into a fire. It could explode, resulting in injuries.

Handle the toner cartridges carefully. If toner scatters on your hands or clothes, wipe or wash it off with cold water at once.

To avoid print quality problems, DO NOT touch the shaded parts shown in the illustrations.

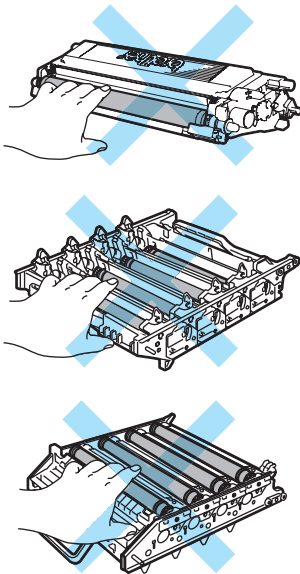

- 5 Push to release the latches of the white corona wire cover (1), and then open the cover.

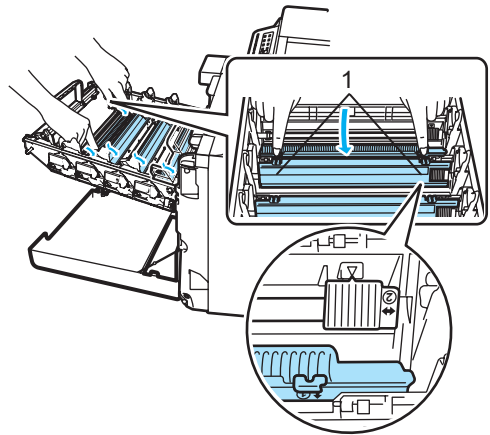

Note

We recommended that you clean the corona wire for each of the colors. If you want to clean only the corona wire of the color that caused the print quality problem, see the illustration below to identify the position of each of the corona wires.

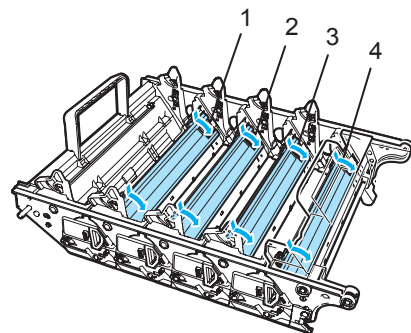

- 1 Corona wire cover for Black (K)
- 2 Corona wire cover for Yellow (Y)
- 3 Corona wire cover for Magenta (M)
- 4 Corona wire cover for Cyan (C)

- 6 Clean the corona wire inside the drum unit by gently sliding the green tab from left to right and right to left several times.

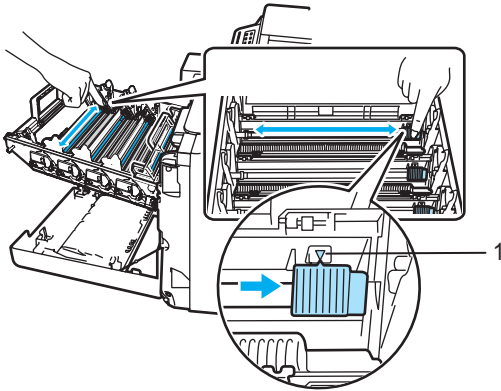

! CAUTION

Be sure to return the tab to the home position (▼) (1). If you do not, printed pages may have a vertical stripe.

- 7 Close the corona wire cover.

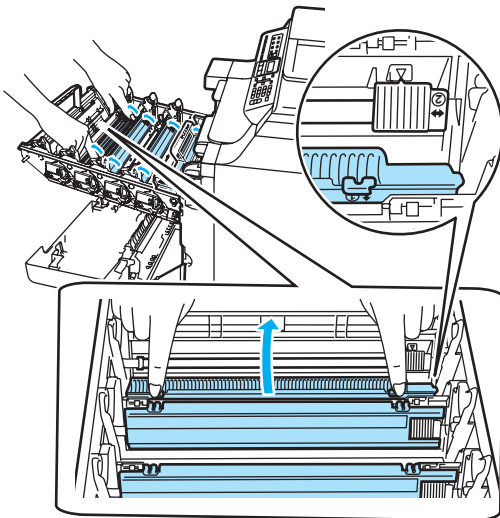

- 8 Repeat 5 to 7 to clean each of the remaining corona wires.

- 9 Hold the handle of the toner cartridge and slide the toner cartridge into the drum unit. Make sure that you match the toner cartridge color to the same color label on the drum unit, and make sure that you fold down the toner cartridge handle (A) once the toner cartridge is in place. Repeat this for all the toner cartridges.

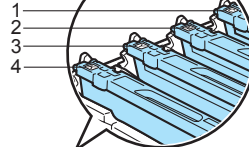
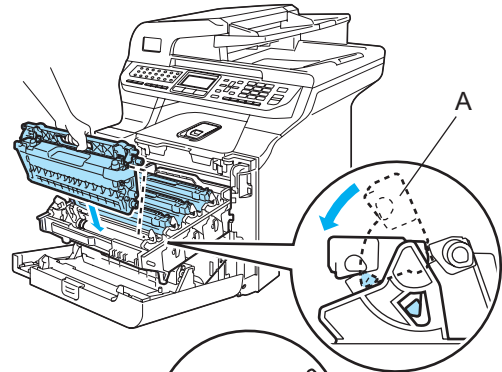

- 1 C - Cyan
- 2 M - Magenta
- 3 Y - Yellow
- 4 K - Black

- 10 Push the drum unit in until it stops.

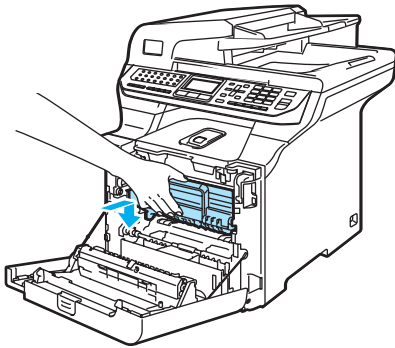
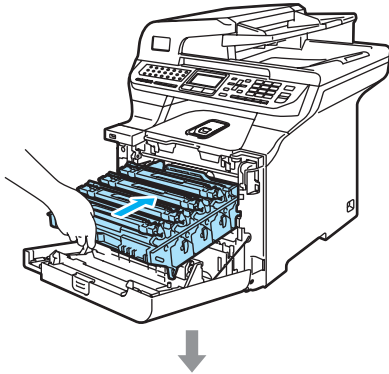

- 11 Close the front cover of the machine.

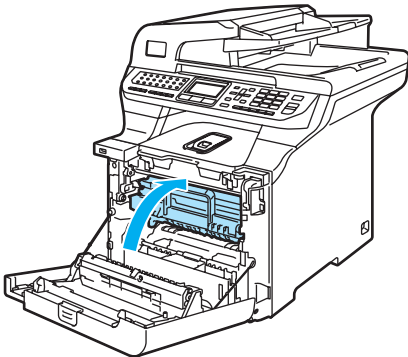

- 12 Plug the machine's power cord back into the AC power outlet first, and reconnect all cables and telephone line cord. Turn on the machine's power switch.

Cleaning the drum unit

If you have the following print quality problems, clean the drum unit as follows.

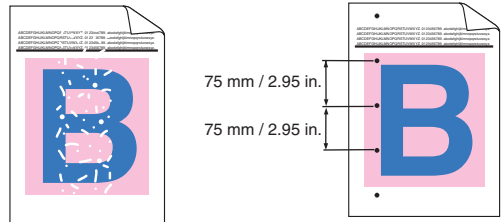

- 1 Press the front cover release button and then open the front cover.

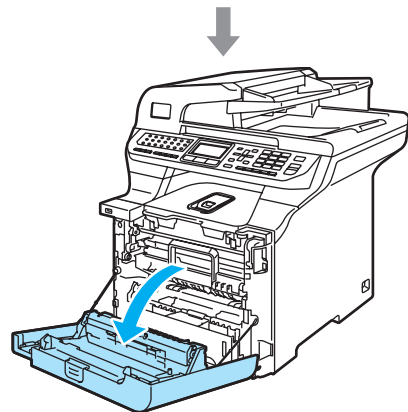
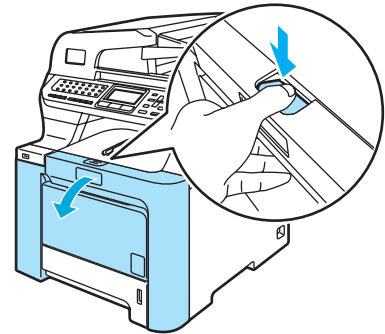

- 2 Close the front cover of the machine. The machine starts warming up, wait until it finishes warming up before going on to step 3.

- 3 Pull out the MP tray (1) and unfold the MP tray support flap (2).

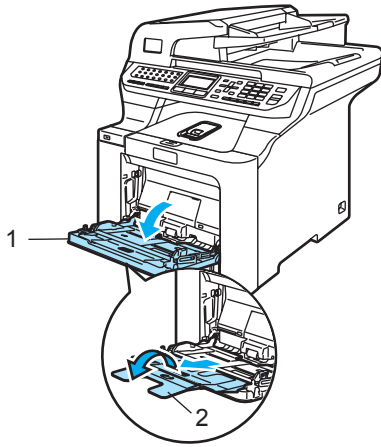

- 4 Put a blank sheet of A4 or Letter sized paper in the MP tray.

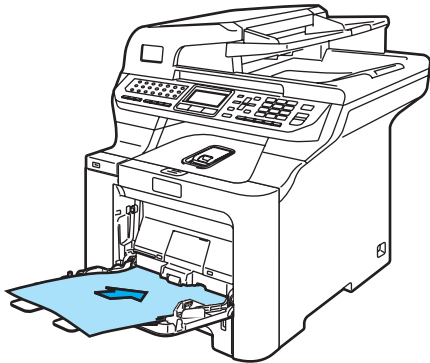

- 5 While pressing and holding down **Clear/Back** press **◀** until **DRUM CLEANING** is displayed on the LCD.



- 6 Press **Black Start** or **Color Start**. The paper will feed into the machine to start the drum cleaning.

- 7 The following message appears on the LCD when the machine has finished cleaning.

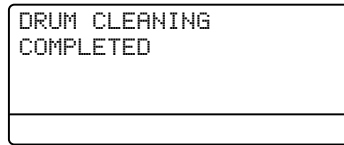

- 8 Press **Stop/Exit** so that the machine returns to the Ready state.

- 9 Try to print again. If this problem still remains, repeat steps 3 to 8 several times. If the problem still remains after repeating step 3 to 8 several times, go to step 10.

- 10 Turn off the machine's power switch. Unplug the telephone line cord first, disconnect all cables, and then unplug the power cord from the AC power outlet.

- 11 Press the front cover release button and then open the front cover.

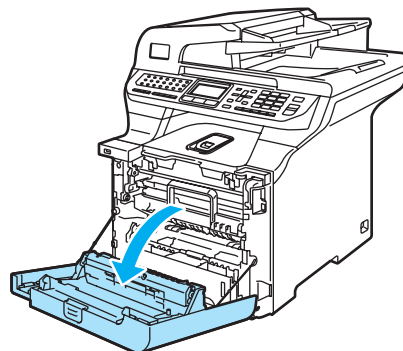
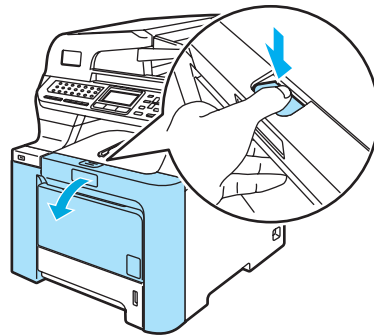

- 12 Hold the green handle of the drum unit. Lift the drum unit up and then pull it out until it stops.

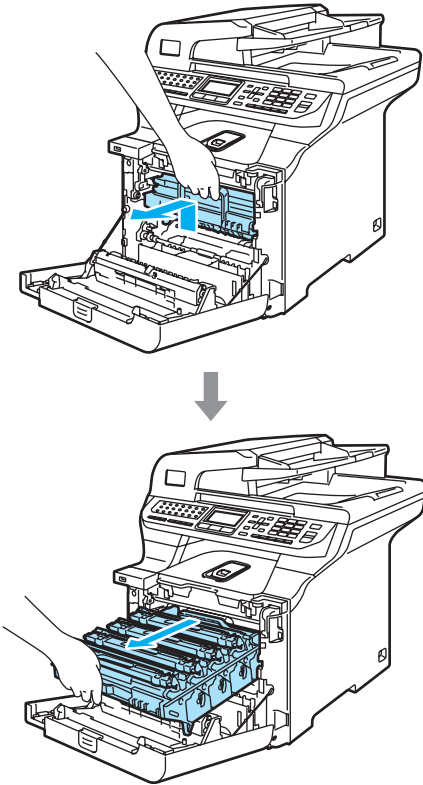

- 13 Release the gray lock lever (1) that is on the left side of the machine. Lift the front of the drum unit and pull the drum unit completely out of the machine using the green handles on the drum unit.

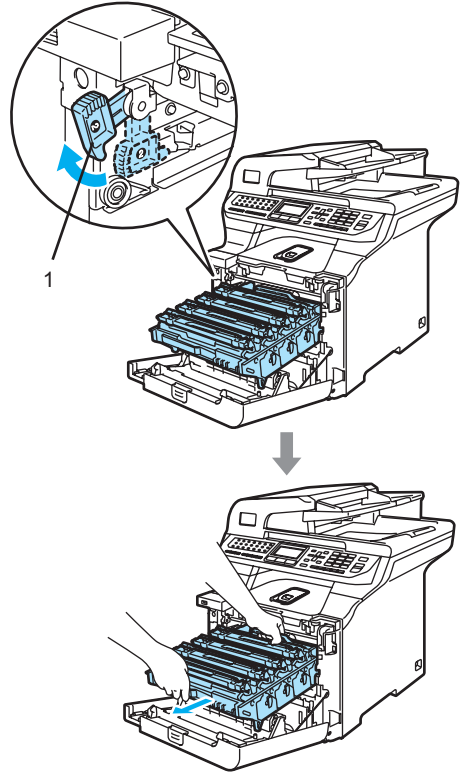

! CAUTION

Hold the handles of drum unit when you carry it. **DO NOT** hold the sides of the drum unit.

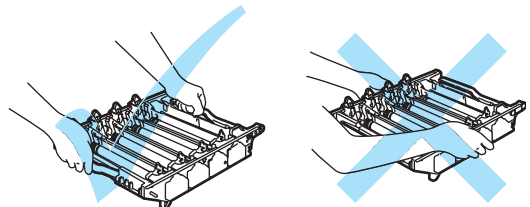

! CAUTION

We recommend that you place the drum unit on a clean, flat surface with a piece of disposable paper underneath it in case you accidentally spill or scatter toner.

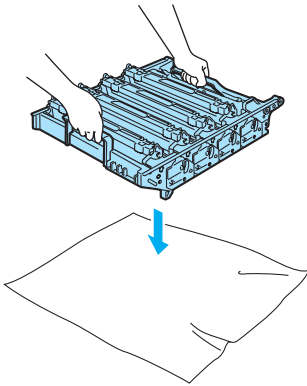

! CAUTION

We recommend that you place the toner cartridges on a clean, flat surface with a piece of disposable paper underneath it in case you accidentally spill or scatter toner.

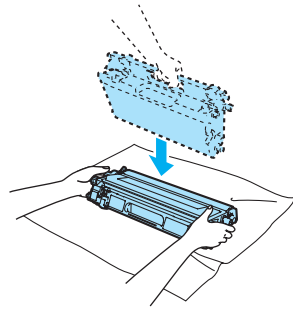

Handle the toner cartridge carefully. If toner scatters on your hands or clothes, wipe or wash it off with cold water at once.

- 14** Hold the handle of the toner cartridge and pull it out of the drum unit. Repeat this for all of the toner cartridges.

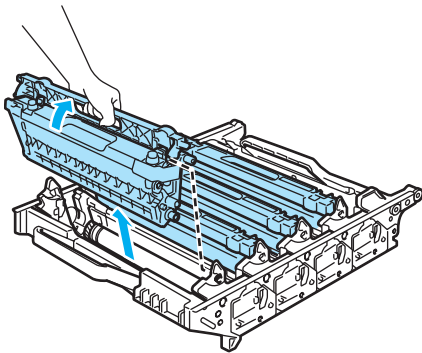

To prevent damage to the machine from static electricity, DO NOT touch the electrodes shown in the illustration.

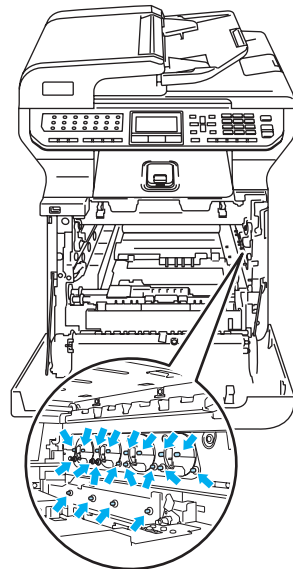

! CAUTION

To avoid print quality problems, **DO NOT** touch the shaded parts shown in the illustrations.

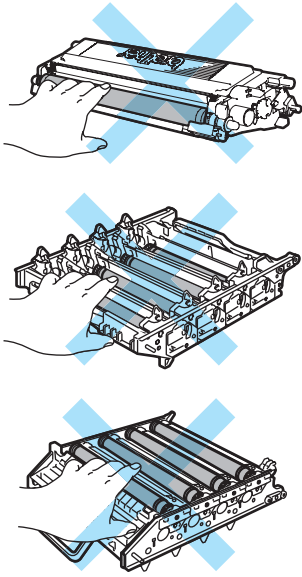

- 15 Turn the drum unit over by holding the green handles. Make sure that the drum unit gears (1) are on the left hand side.

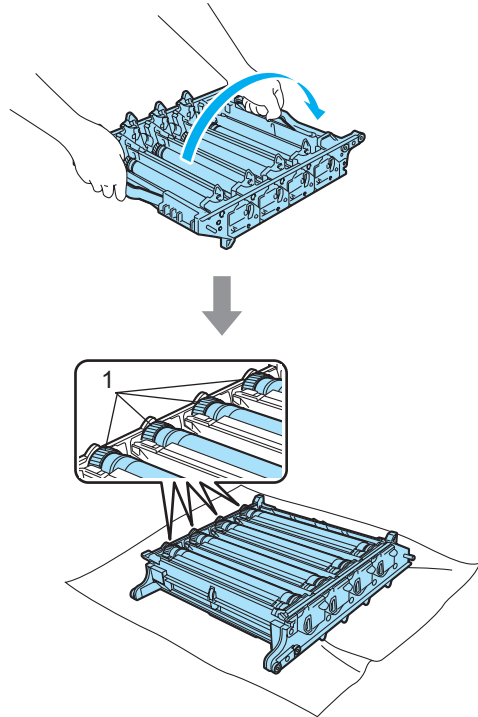

- 16 See the print sample to identify the color causing the problem. The color of the spots or toner stain is the color of the drum you should clean. For example, if the spots are cyan, you should clean the drum for cyan. Put the print sample in front of the drum, and find the exact position of the poor print.

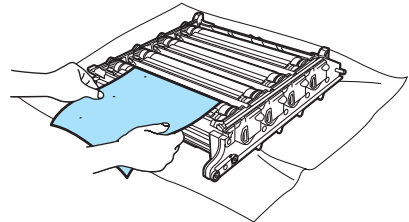

- 17 Turn the drum unit gear toward you by hand while looking at the surface of the drum (1).

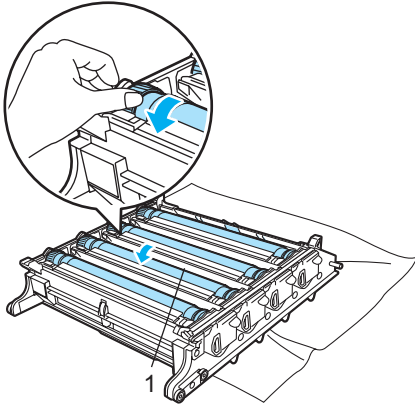

- 18 When you have found the mark on the drum that matches the print sample, wipe the surface of the drum gently with a cotton swab until the dust or paper powder on the surface comes off.

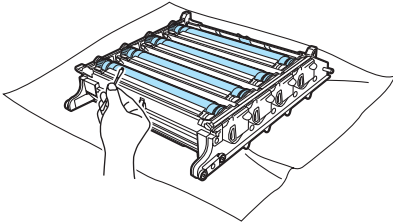

- 19 Turn the drum unit gear toward you by hand to return it to the home position. The home position of each drum can be identified by matching the number on the drum unit gear to the same number on the side of the drum unit as shown in the illustration. Make sure that the number on each of the four drum unit gears matches the corresponding number on the side of the drum unit.

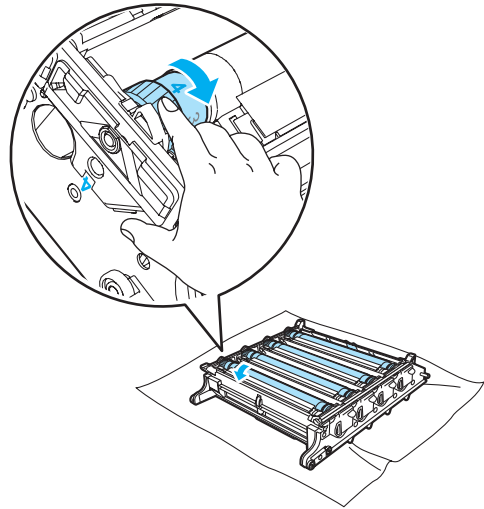

! CAUTION

The drum is photosensitive so **DO NOT** touch it with your fingers.

DO NOT clean the surface of the photosensitive drum with a sharp object.

DO NOT use a scrubbing or wiping motion because this might damage the drum.

- 20 Hold the handle of the toner cartridge and slide the toner cartridge into the drum unit. Make sure that you match the toner cartridge color to the same color label on the drum unit, and make sure that you fold down the toner cartridge handle (A) once the toner cartridge is in place. Repeat this for all the toner cartridges.

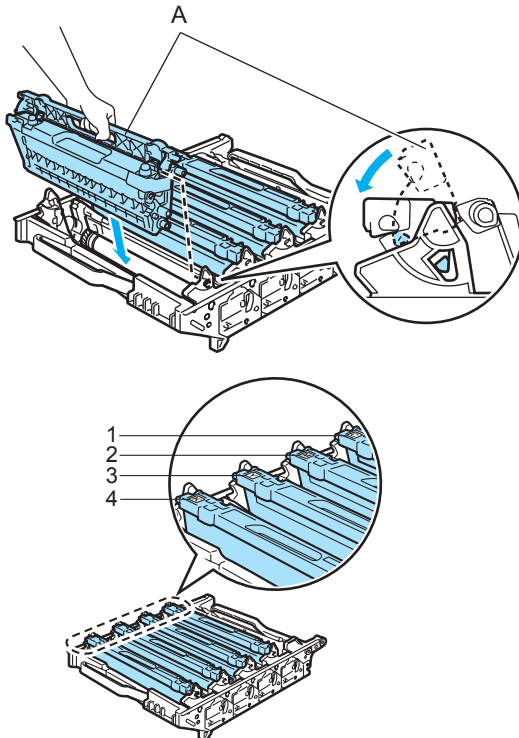

- 1 C - Cyan
- 2 M - Magenta
- 3 Y - Yellow
- 4 K - Black

- 21 Put the drum unit back in the machine as follows.

- 1 Make sure that the gray lock lever (1) is in the up position and put the drum unit in the machine. Push down the gray lock lever (1).

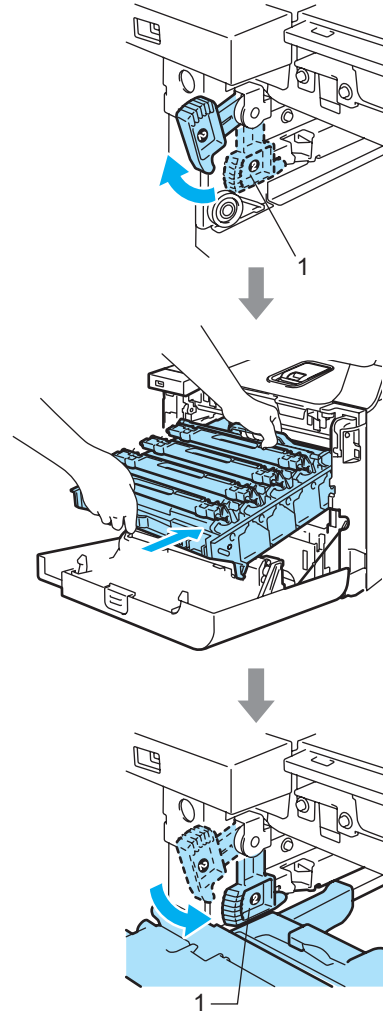

C

 **Note**

When you put the drum unit in the machine, match the green guides (1) of the drum unit handle to the green arrows (2) on both sides of the machine.

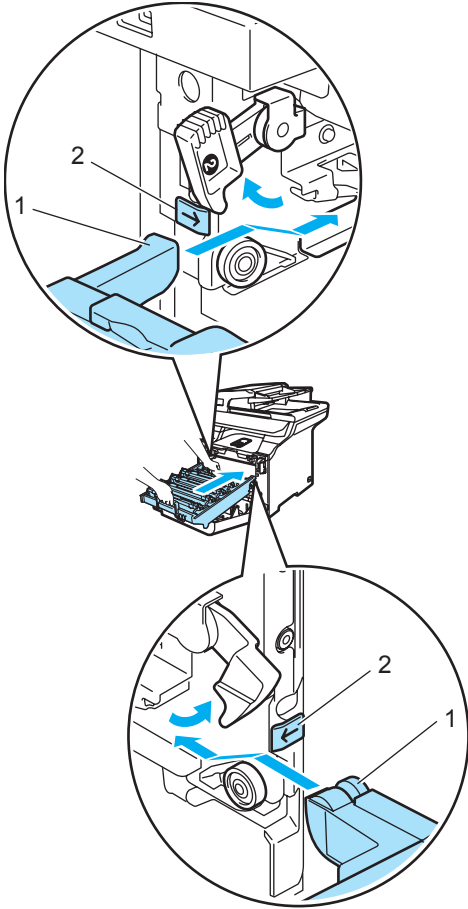

2 Push the drum unit in until it stops.

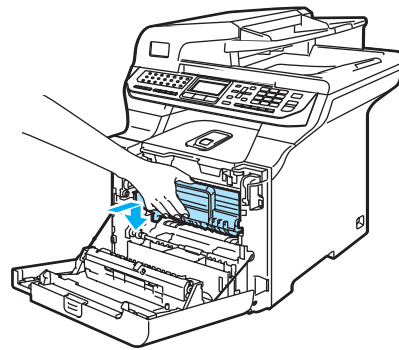
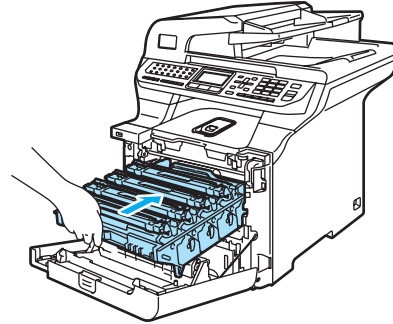

22 Close the front cover of the machine.

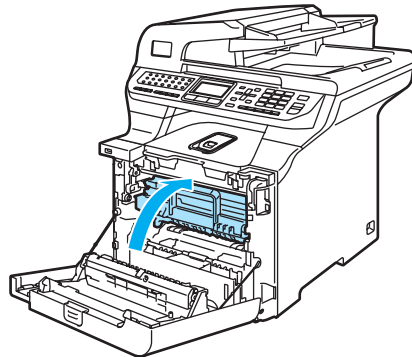

23 Plug the machine's power cord back into the AC power outlet first, and reconnect all cables and telephone line cord. Turn on the machine's power switch.

Replacing the consumable items

You will need to replace the following consumable items regularly. When the time comes to replace consumable items, the following messages will appear on the LCD.

The machine will stop printing when the following maintenance messages appear on the LCD.

LCD messages	Consumable item to replace	Approximate life	How to replace	Order No.
Toner Life End Replace Black(K) Toner Cartridge. ¹	Toner cartridges standard	2,500 pages (Black) ² 1,500 pages (Cyan, Magenta, Yellow) ²	See <i>Replacing a toner cartridge</i> on page 172.	TN-110BK TN-110C TN-110M TN-110Y
	Toner cartridges high yield	5,000 pages (Black) ² 4,000 pages (Cyan, Magenta, Yellow) ²		TN-115BK TN-115C TN-115M TN-115Y
Waste Toner Full	Waste toner box	20,000 pages ³	See <i>Waste Toner Box Full</i> message on page 188.	WT-100CL

¹ The toner cartridge color which is used up is shown in the message.

² Approx. yields based on 5% page coverage (Letter). The actual number of printed pages will vary depending on the print jobs and paper you use.

³ When printing on Letter size paper at 5% print coverage for CMYK each. The actual number of printed pages will vary depending on the print jobs and paper you use.

The following are maintenance messages that appear on the LCD in the Ready mode. These message provide advanced warnings to replace the consumable items before they run out. To avoid any inconvenience, you may wish to buy spare consumable items before the machine stops printing.

LCD messages	Consumable item to replace	Approximate life	How to replace	Order No.
Toner Low Prepare New Black(K) Toner Cartridge. ¹	Toner cartridges standard	2,500 pages (Black) ² 1,500 pages (Cyan, Magenta, Yellow) ²	See <i>Replacing a toner cartridge</i> on page 172.	TN-110BK TN-110C TN-110M TN-110Y
	Toner cartridges high yield	5,000 pages (Black) ² 4,000 pages (Cyan, Magenta, Yellow) ²		TN-115BK TN-115C TN-115M TN-115Y
Change Parts Waste Toner Box	Waste toner box	20,000 pages ³	See <i>Replacing the waste toner box</i> on page 188.	WT-100CL

¹ The toner cartridge color which is near the end of life is shown in the message.

² Approx. yields based on 5% page coverage (Letter). The actual number of printed pages will vary depending on the print jobs and paper you use.

³ When printing on Letter size paper at 5% print coverage for CMYK each. The actual number of printed pages will vary depending on the print jobs and paper you use.

The following are maintenance messages that appear alternately with the normal message on the upper row of the LCD when the machine is in the Ready mode. These messages advise you that you will need to replace each of the consumable items as soon as possible, since the consumable item's end of life has been reached. The machine will continue printing when any of these messages appear on the LCD.

LCD messages	Consumable item to replace	Approximate life	How to replace	Order No.
Change Parts Drum	Drum unit	17,000 pages ¹	See <i>Replacing the drum unit</i> on page 177.	DR-110CL
Change Parts Belt Unit	Belt unit	50,000 pages ²	See <i>Replacing the belt unit</i> on page 183.	BU-100CL
Change Parts Fuser Unit	Fuser unit	80,000 pages ³	Call Brother Customer Service to replace the fuser unit.	—
Change Parts Laser Unit	Laser unit	100,000 pages ³	Call Brother Customer Service to replace the laser unit.	—
Change Parts PF Kit 1	Paper feeding kit 1 (Paper pick-up roller and Separator pad for Tray 1)	100,000 pages ³	Call Brother Customer Service to replace the paper feeding kit 1.	—
Change Parts PF Kit 2 (when the optional lower tray is installed)	Paper feeding kit 2 (Paper pick-up roller and Separator pad for Tray 2)	100,000 pages ³	Call Brother Customer Service to replace the paper feeding kit 2.	—
Change Parts PF Kit MP	Paper feeding kit MP (Paper pick-up roller and Separator pad for MP tray)	50,000 pages ³	Call your Brother dealer or Brother Customer Service to replace the paper feeding kit MP.	—

¹ Drum yield is approximate, and may vary by type of use.

² When printing on Letter size paper.

³ When printing on Letter or A4 size paper. The actual number of printed pages will vary depending on the print jobs and paper you use.



Note

- Discard used consumable items according to local regulations, keeping it separate from domestic waste. If you have questions, call your local waste disposal office. Be sure to reseal the consumable items tightly so that the material inside does not spill.
- We recommend placing used consumable items on a piece of paper to prevent accidentally spilling or scattering the material inside.
- If you use paper that is not a direct equivalent for the recommended paper, the life of consumable items and machine parts may be reduced.
- The projected life for toner cartridges and a waste toner box is based on an average 5% coverage of the printable area using any color toner cartridge. Frequency of replacement will vary depending on the complexity of printed pages, percentage of coverage and type of media used.

Replacing a toner cartridge

Order Numbers:

Toner Cartridge Standard:
TN-110 (BK, C, M, Y)

Toner Cartridge High Yield:
TN-115 (BK, C, M, Y)

The High Yield toner cartridges can print approximately 5,000 pages (Black) and approximately 4,000 pages each (Cyan, Magenta and Yellow). The Standard toner cartridges can print approximately 2,500 pages (Black) and approximately 1,500 pages each (Cyan, Magenta and Yellow). Actual page count will vary depending on your average type of document (i.e., standard letter, detailed graphics).

Toner low message

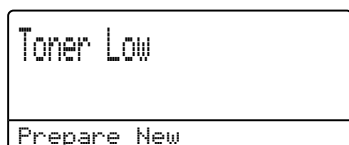

The machine is supplied with the Standard TN-110 toner cartridge that must be replaced after approximately 2,500 pages (Black) and 1,500 pages each (Cyan, Magenta and Yellow). When a toner cartridge is running low, the LCD shows `Toner Low`. (For details about the specific order number for each toner cartridge color by page yield, see *Ordering accessories and supplies* on page iii.)

Note

It is a good idea to keep new toner cartridges ready for use when you see the `Toner Low` warning.

Toner life end message

When the following message appears on the LCD, you need to replace the toner cartridge. The second line of the LCD indicates which color you need to replace.



Discard the used toner cartridge according to local regulations, keeping it separate from domestic waste. Be sure to seal up the toner cartridge tightly so that toner powder does not spill out of the cartridge. If you have questions, call your local waste disposal office.

Note

We recommend that you clean the machine and corona wires of the drum unit when you replace a toner cartridge. (See *Cleaning the laser scanner windows* on page 154 and *Cleaning the corona wires* on page 158.)

Replacing the toner cartridges



HOT SURFACE

After you have just used the machine, some internal parts of the machine will be extremely hot. When you open the front or back cover of the machine, DO NOT touch the shaded parts shown in the illustration.

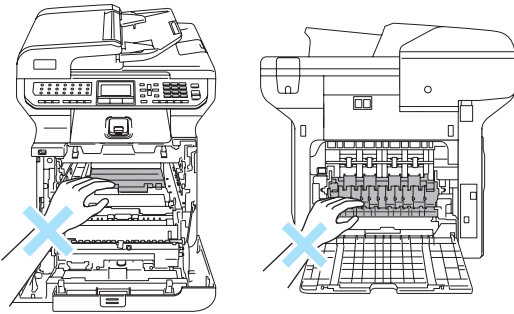

- 1 Press the front cover release button and then open the front cover.

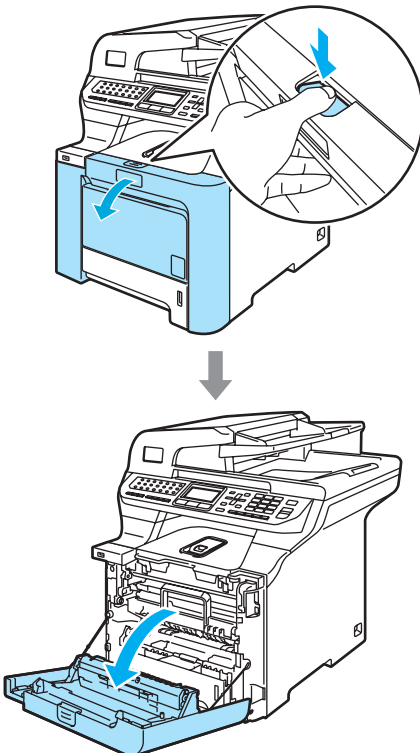

- 2 Hold the green handle of the drum unit. Lift the drum unit up and then pull it out until it stops.

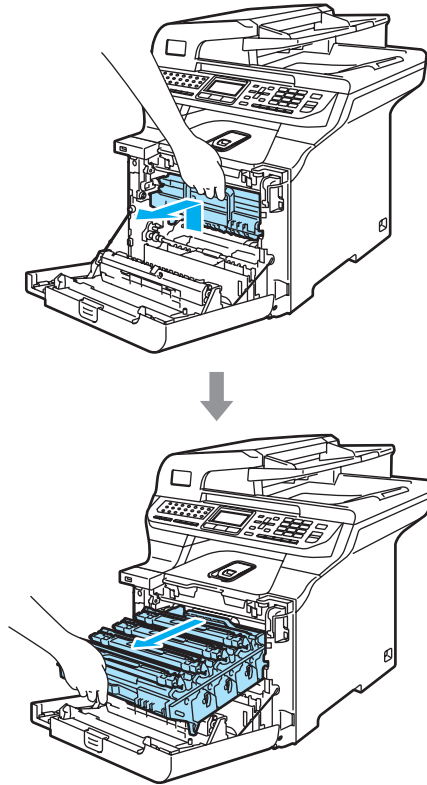

- 3 Hold the handle of the toner cartridge and pull it out of the drum unit. Repeat this for all the toner cartridges.

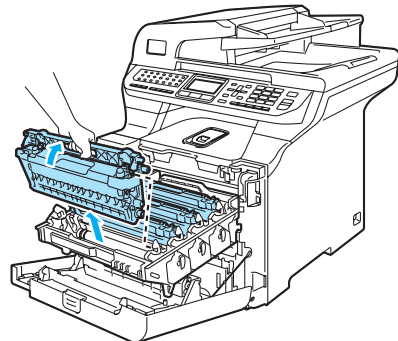

! CAUTION

We recommend that you place the toner cartridges on a clean, flat surface with a piece of disposable paper underneath it in case you accidentally spill or scatter toner.

DO NOT put a toner cartridge into a fire. It could explode, resulting in injuries.

Handle the toner cartridges carefully. If toner scatters on your hands or clothes, wipe or wash it off with cold water at once.

To avoid print quality problems, DO NOT touch the shaded parts shown in the illustrations.

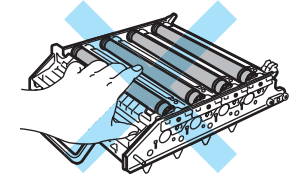
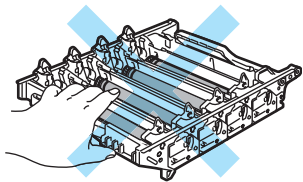
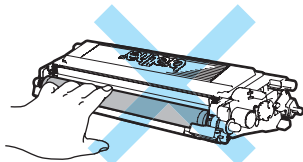

! CAUTION

Brother strongly recommends that you DO NOT refill the toner cartridges provided with your machine. We also strongly recommend that you continue to use only Genuine Brother Brand replacement toner cartridges. Use or attempted use of potentially incompatible toner and/or cartridges in the Brother machine may cause damage to the machine and/or may result in unsatisfactory print quality. Our warranty coverage does not apply to any problem that is caused by the use of unauthorized third party toner and/or cartridges. To protect your investment and obtain premium performance from the Brother machine, we strongly recommend the use of Genuine Brother Supplies.

Wait to unpack the toner cartridge until immediately before you put it in the machine. If a toner cartridge is left unpacked for a long time, the toner life will be shortened.

Note

- Be sure to seal up the toner cartridge tightly in a suitable bag so that toner powder does not spill out of the cartridge.
- Discard the used toner cartridge according to local regulations, keeping it separate from domestic waste. If you have questions, call your local waste disposal office.

! CAUTION

DO NOT use flammable substances near the machine. DO NOT use any type of spray to clean the inside or outside of the machine. Doing this may cause a fire or electrical shock. Refer to *Routine maintenance* on page 152 for how to clean the machine.

4 Clean the corona wires as follows.

- 1** Push to release the latches of the white corona wire cover (1), and then open the cover.

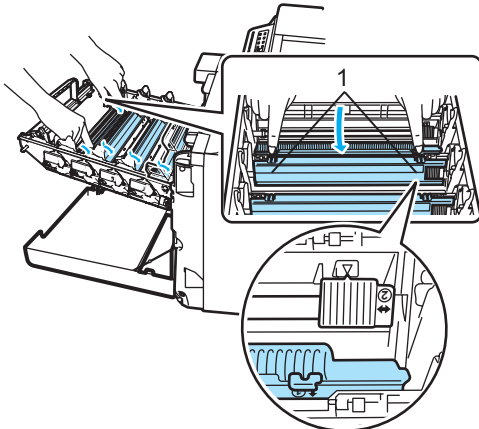

- 2** Clean the corona wire inside the drum unit by gently sliding the green tab from left to right and right to left several times.

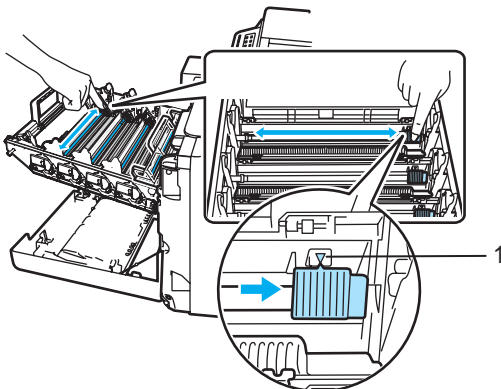

! CAUTION

Be sure to return the tab to the home position (▼) (1). If you do not, printed pages may have a vertical stripe.

- 3** Close the corona wire cover.

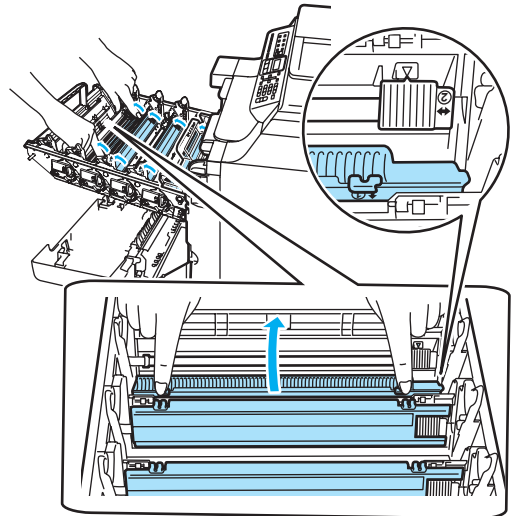

- 4** Repeat step 1 through step 3 to clean each of the remaining three corona wires.

- 5** Unpack the new toner cartridge. Hold the cartridge level with both hands and gently rock it from side to side five or six times to spread the toner evenly inside the cartridge.

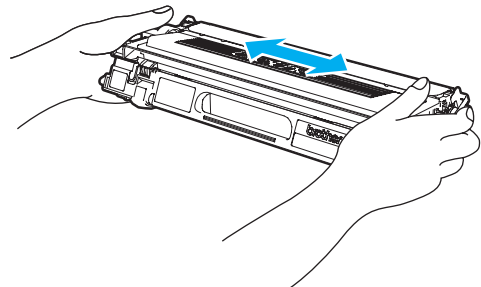

- 6 Remove the orange protective cover.

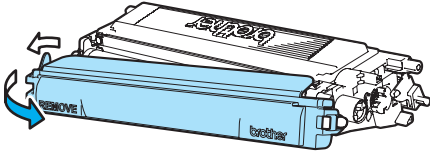

- 7 Hold the handle of the toner cartridge and slide the toner cartridge into the drum unit. Make sure that you match the toner cartridge color to the same color label on the drum unit, and make sure that you fold down the toner cartridge handle (A) once the toner cartridge is in place. Repeat this for all the toner cartridges.

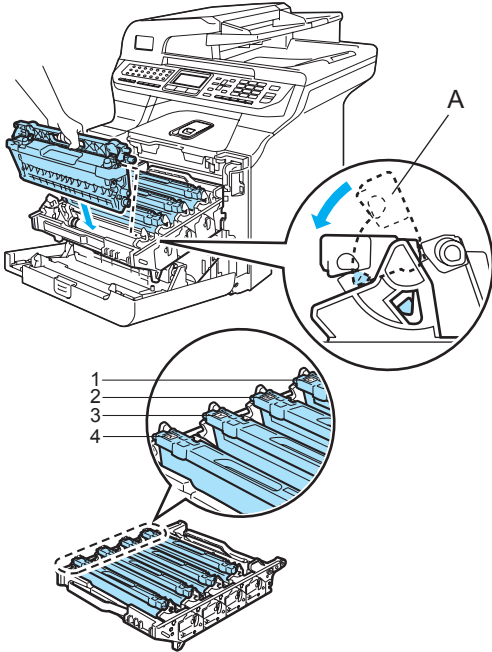

- 1 C - Cyan
- 2 M - Magenta
- 3 Y - Yellow
- 4 K - Black

- 8 Push the drum unit in until it stops.

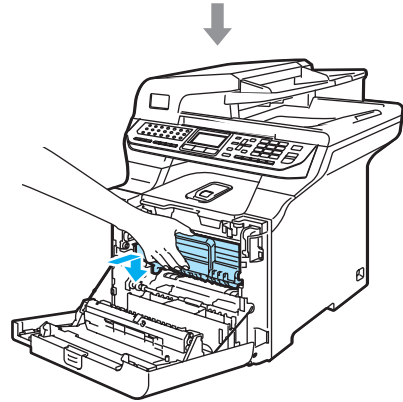
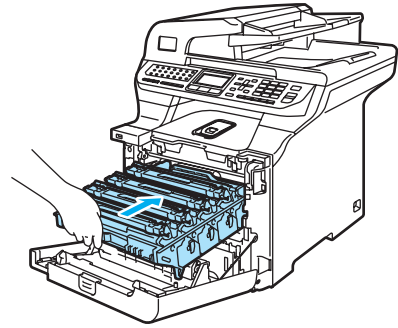

- 9 Close the front cover of the machine.

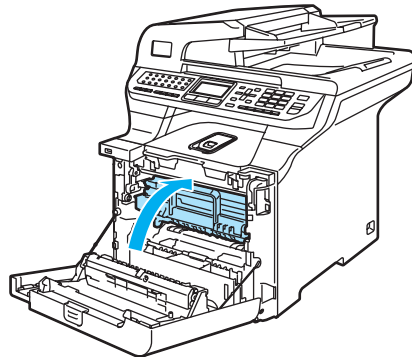

Replacing the drum unit

Order Number: DR-110CL

Change Parts Drum message

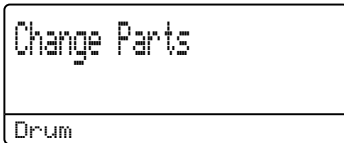

The machine uses a drum unit to create print images on paper. If the LCD shows *Change Parts Drum*, the drum unit is near the end of its life and it is time to buy a new one.

Even if the LCD shows *Change Parts Drum*, you may be able to continue printing without having to replace the drum unit for a while. However, if there is a noticeable deterioration in the output print quality (even before *Change Parts Drum* appears), then the drum unit should be replaced. You should clean the machine when you replace the drum unit. (See *Cleaning the laser scanner windows* on page 154.)

! CAUTION

While removing the drum unit, handle it carefully because it may contain toner. If toner scatters on your hands or clothes, wipe or wash it off with cold water at once.

Note

The drum unit is a consumable item, and it is necessary to replace it periodically. There are many factors that determine the actual drum life, such as temperature, humidity, type of paper and how much toner you use for the number of pages per print job. The estimated drum life is approximately 17,000 pages. The actual number of pages your drum will print may be significantly less than these estimates. Because we have no control over the many factors that determine the actual drum life, we cannot guarantee a minimum number of pages that will be printed by your drum.

Replacing the drum unit

! CAUTION

Wait to unpack a new drum unit until immediately before installing it. Put the old drum unit into the plastic bag.

HOT SURFACE

After you have just used the machine, some internal parts of the machine will be extremely hot. When you open the front or back cover of the machine, DO NOT touch the shaded parts shown in the illustration.

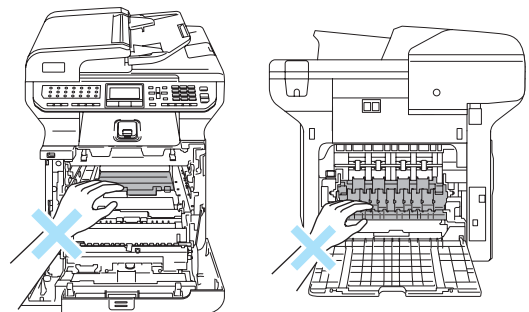

- 1 Turn off the machine's power switch. Press the front cover release button and then open the front cover.

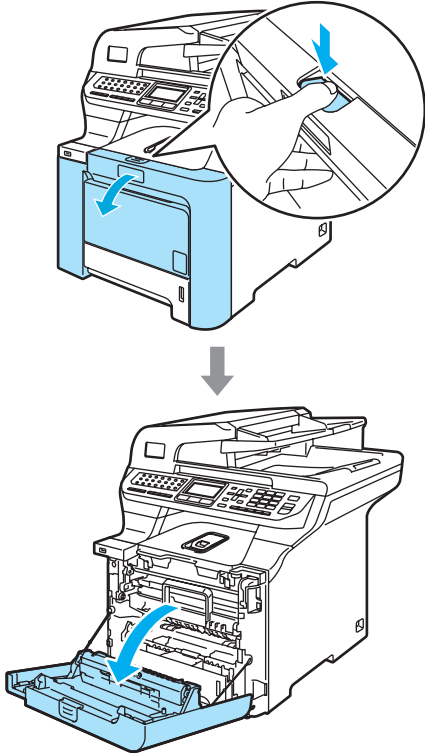

- 2 Hold the green handle of the drum unit. Lift the drum unit up and then pull it out until it stops.

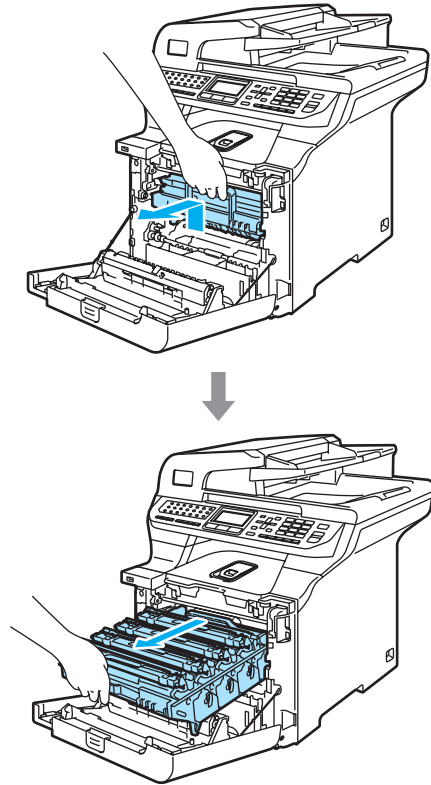

- Release the gray lock lever (1) that is on the left side of the machine. Lift the front of the drum unit and pull the drum unit completely out of the machine using the green handles on the drum unit.

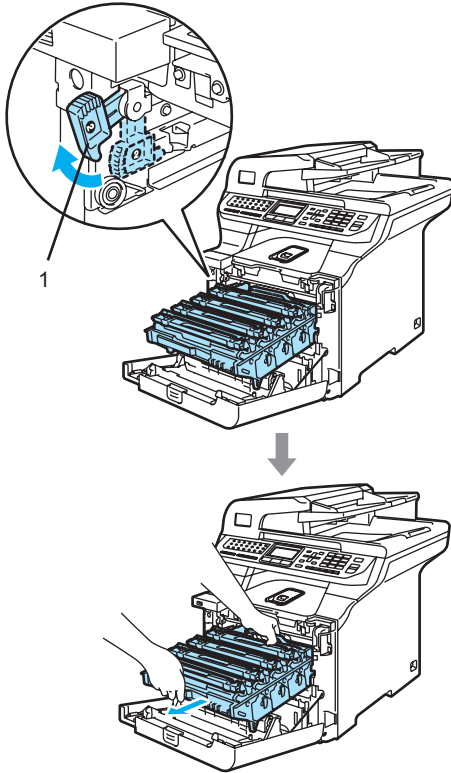

! CAUTION

We recommend that you place the drum unit on a clean, flat surface with a piece of disposable paper underneath it in case you accidentally spill or scatter toner.

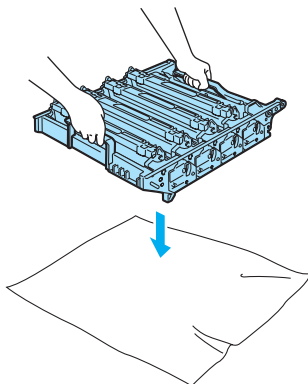

Note

Discard the used drum unit according to local regulations, keeping it separate from domestic waste. Be sure to seal up the drum unit tightly so that toner powder does not spill out of the unit. If you have questions, call your local waste disposal office.

! CAUTION

To prevent damage to the machine from static electricity, DO NOT touch the electrodes shown in the illustration.

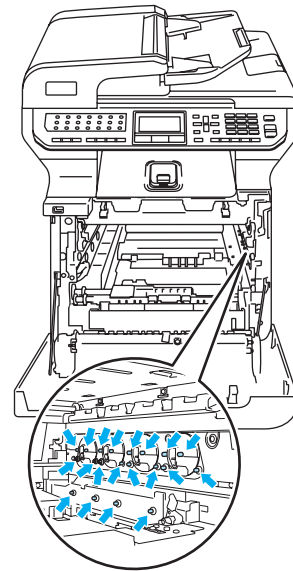

Hold the handles of drum unit when you carry it. DO NOT hold the sides of the drum unit.

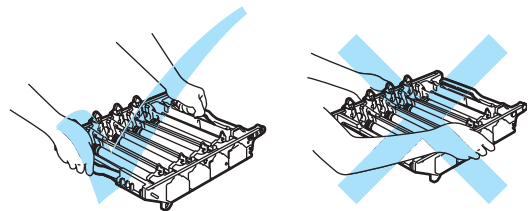

To avoid print quality problems, DO NOT touch the shaded parts shown in the illustrations.

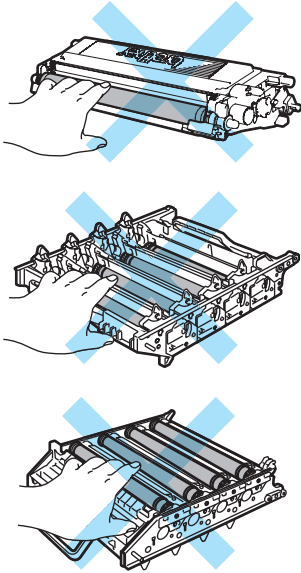

- 4 Hold the handle of the toner cartridge and pull it out of the drum unit. Repeat this for all the toner cartridges.

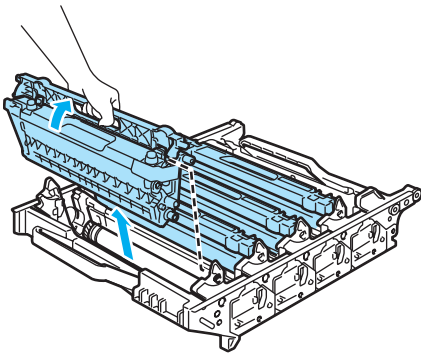

! CAUTION

We recommend that you place the toner cartridges on a clean, flat surface with a piece of disposable paper underneath it in case you accidentally spill or scatter toner.

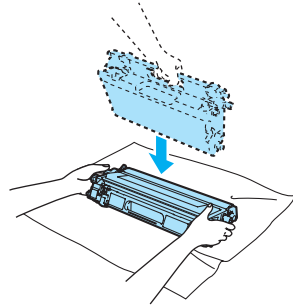

Handle the toner cartridge carefully. If toner scatters on your hands or clothes, wipe or wash it off with cold water at once.

- 5 Unpack the new drum unit and remove the protective cover.

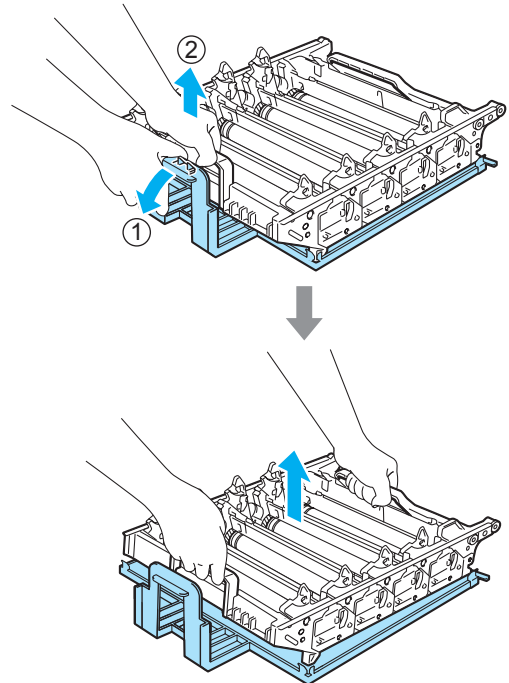

- 6** Hold the handle of the toner cartridge and slide the toner cartridge into the drum unit. Make sure that you match the toner cartridge color to the same color label on the drum unit, and make sure that you fold down the toner cartridge handle (A) once the toner cartridge is in place. Repeat this for all the toner cartridges.

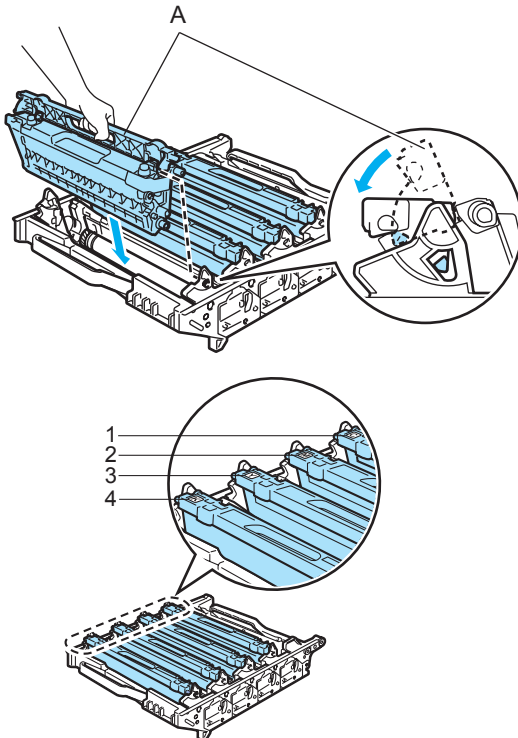

- 1 C - Cyan
- 2 M - Magenta
- 3 Y - Yellow
- 4 K - Black

- 7** Put the drum unit back in the machine as follows.

- 1** Make sure that the gray lock lever (1) is in the up position and put the drum unit in the machine. Push down the gray lock lever (1).

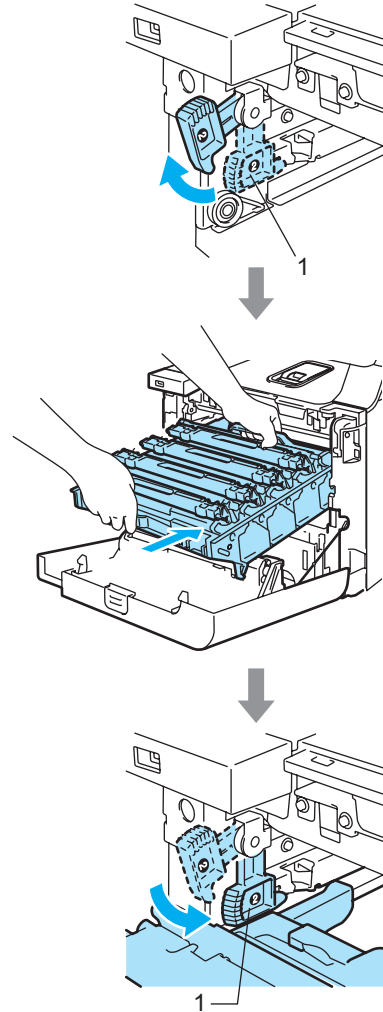

 **Note**

When you put the drum unit in the machine, match the green guides (1) of the drum unit handle to the green arrows (2) on both sides of the machine.

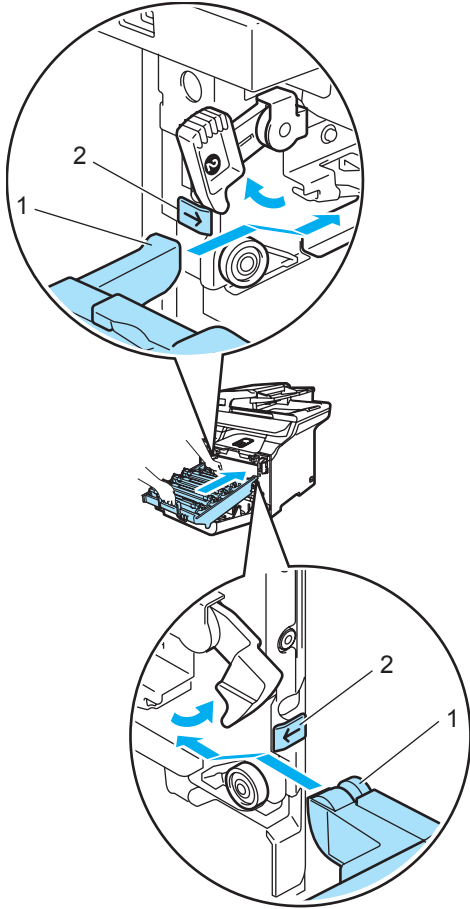

- 2** Push the drum unit in until it stops.

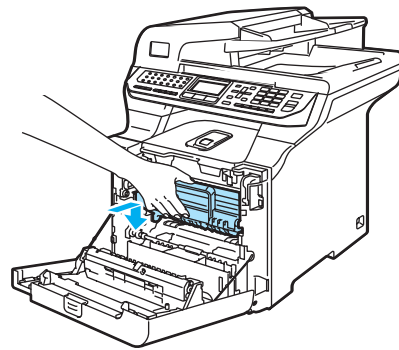
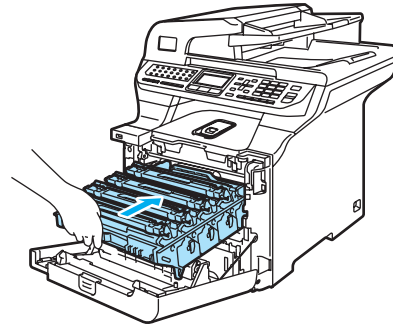

- 8** Close the front cover of the machine.

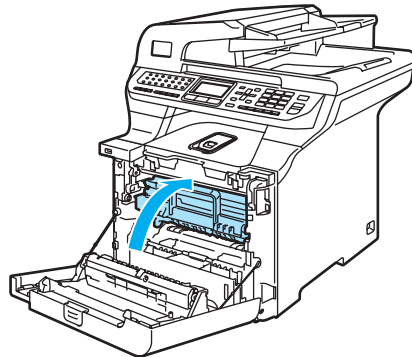

When you replace the drum unit with a new one, you need to reset the drum unit counter by completing the following steps:

- 9** Turn on the machine's power switch.

- 10 Press **Menu, 8, 4**.
The LCD shows the parts name which needs to be reset the counter.

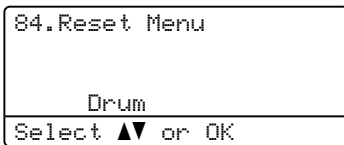

- 11 Press **▲** or **▼** to choose **Drum**.
Press **OK**.
- 12 Press **1** to reset the drum unit counter.
- 13 Press **Stop/Exit**.

Replacing the belt unit

Order Number: BU-100CL

Change Parts Belt Unit message

When the belt unit runs out, the following message appears on the LCD. When you see this message, you must replace the belt unit:

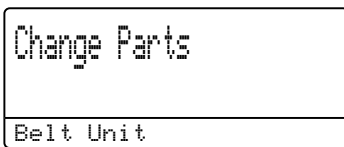

! CAUTION

DO NOT touch the surface of the belt unit.
If you touch it, it could degrade print quality.

Damage caused by improper handling of
the belt unit may void your warranty.

Replacing the belt unit

- 1 Turn off the machine's power switch.
Press the front cover release button and then open the front cover.

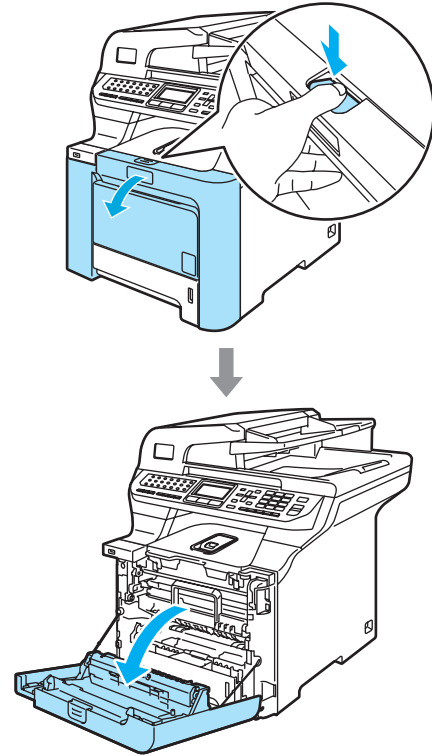

- 2 Hold the green handle of the drum unit. Lift the drum unit up and then pull it out until it stops.

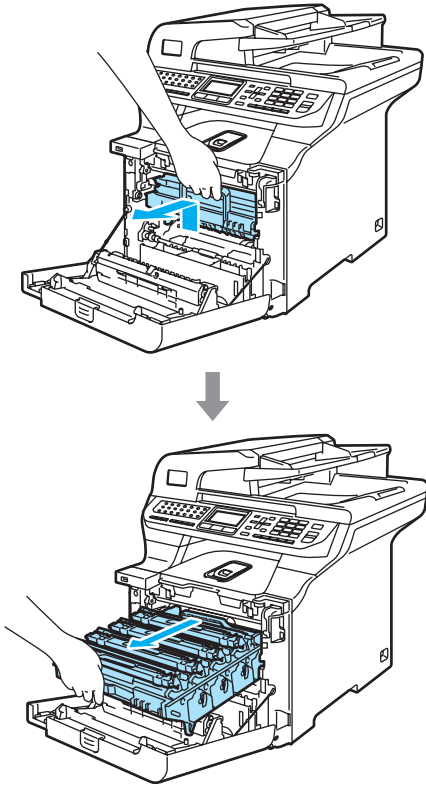

- 3 Release the gray lock lever (1) that is on the left side of the machine. Lift the front of the drum unit and pull the drum unit completely out of the machine using the green handles on the drum unit.

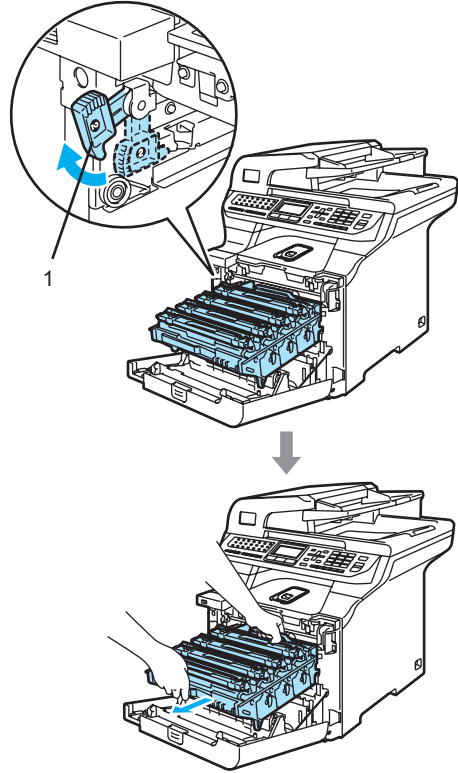

! CAUTION

Hold the handles of drum unit when you carry it. **DO NOT** hold the sides of the drum unit.

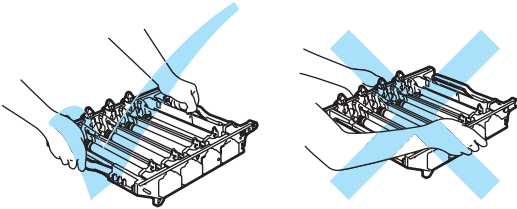

We recommend that you place the drum unit on a clean, flat surface with a piece of disposable paper underneath it in case you accidentally spill or scatter toner.

To prevent damage to the machine from static electricity, **DO NOT** touch the electrodes shown in the illustration.

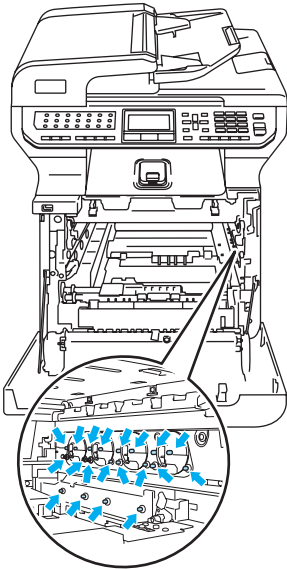

- 4 Hold the green parts of the belt unit with both hands and lift the belt unit up, then pull it out.

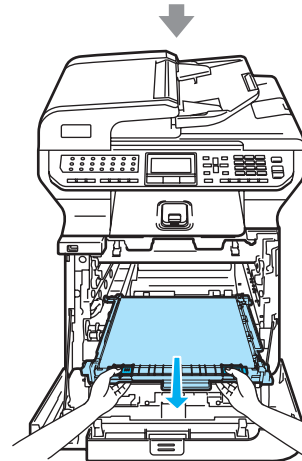
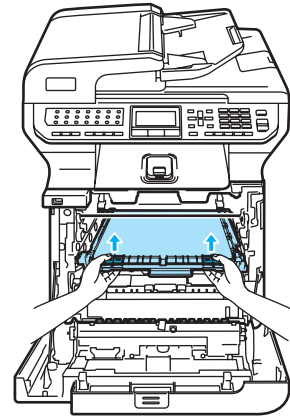

! CAUTION

We recommend that you put the belt unit on a clean, flat surface with a piece of disposable paper underneath it in case you accidentally spill or scatter toner.

- 5 Unpack the new belt unit, and remove the protective cover and paper.

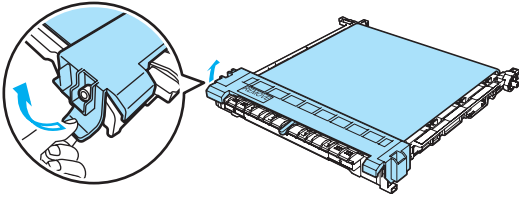

- 6 Put the new belt unit in the machine. Match the ↓ mark on the belt unit to the ↑ mark on the machine. Push down on the green area of the belt unit to lock it in place.

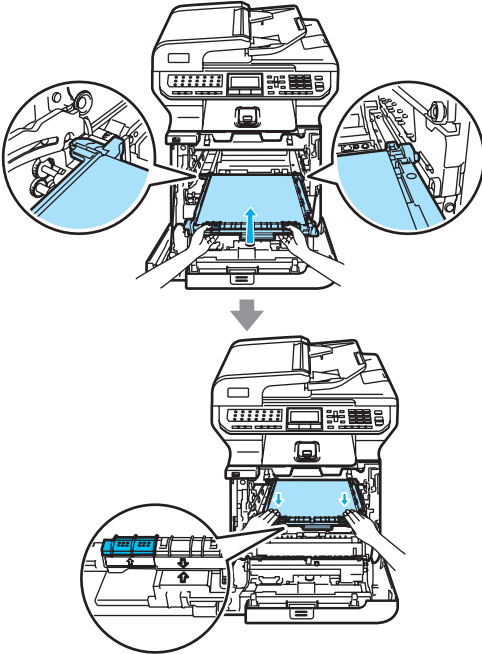

- 7 Put the drum unit back in the machine as follows.

- 1 Make sure that the gray lock lever (1) is in the up position and put the drum unit in the machine. Push down the gray lock lever (1).

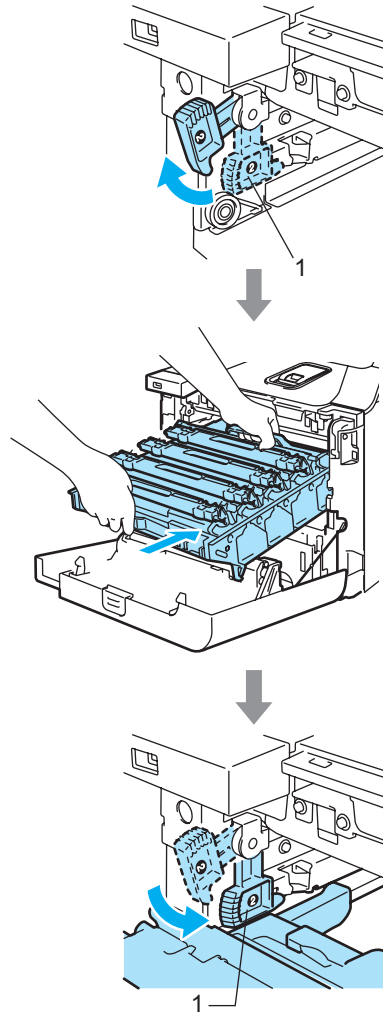



Note

When you put the drum unit in the machine, match the green guides (1) of the drum unit handle to the green arrows (2) on both sides of the machine.

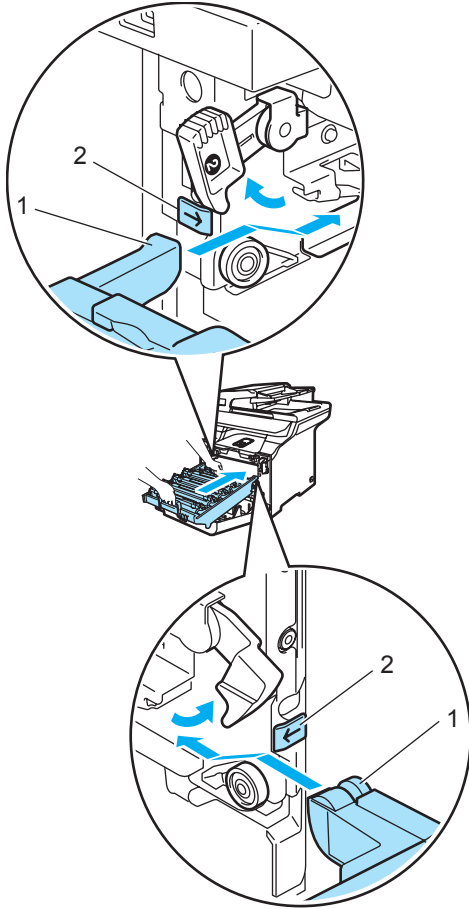

- 2 Push the drum unit in until it stops.

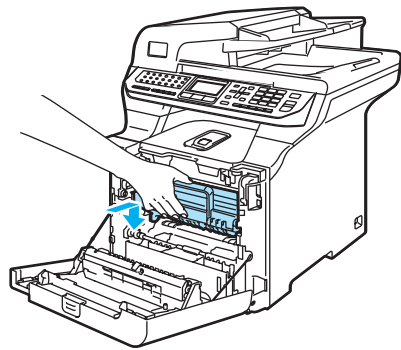
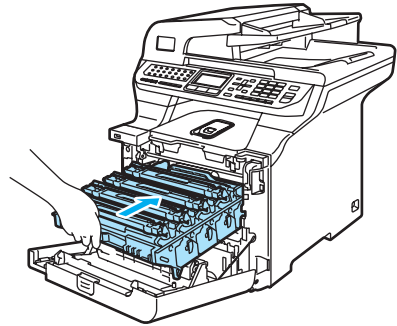

- 8 Close the front cover of the machine.

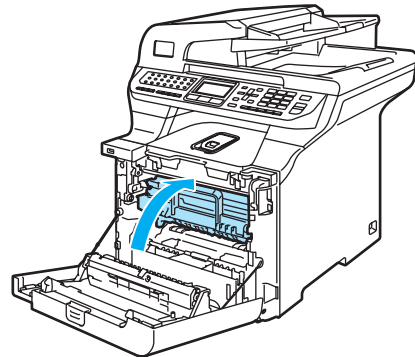

When you replace the belt unit with a new one, you need to reset the belt unit counter by completing the following steps:

- 9 Turn on the machine's power switch.

- 10 Press **Menu**, **8**, **4**.
The LCD shows the parts name which needs to be reset the counter.

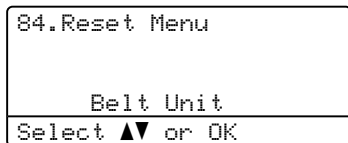

- 11 Press **▲** or **▼** to choose **Belt Unit**.
Press **OK**.
- 12 Press **1** to reset the belt unit counter.
- 13 Press **Stop/Exit**.

Replacing the waste toner box

Order Number: WT-100CL

Change Parts Waste Toner Box message

After you have printed approximately 20,000 images at 5% coverage for CMYK each, you must change the waste toner box. The actual number of printed pages will vary depending on the print jobs and paper you use.



Waste Toner Box Full message

When the waste toner box is full, the following message appears on the LCD and the machine will stop printing. When you see this message, you must replace the toner box:

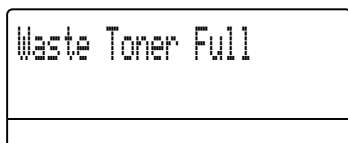

WARNING

DO NOT reuse the waste toner box.

Replacing the waste toner box

WARNING

DO NOT put the waste toner box into a fire.
It could explode.

Be careful not to spill the toner. DO NOT inhale or allow it to get into your eyes.

CAUTION

Handle the waste toner box carefully. If toner scatters on your hands or clothes, wipe or wash it off with cold water at once.

- 1 Press the front cover release button and then open the front cover.

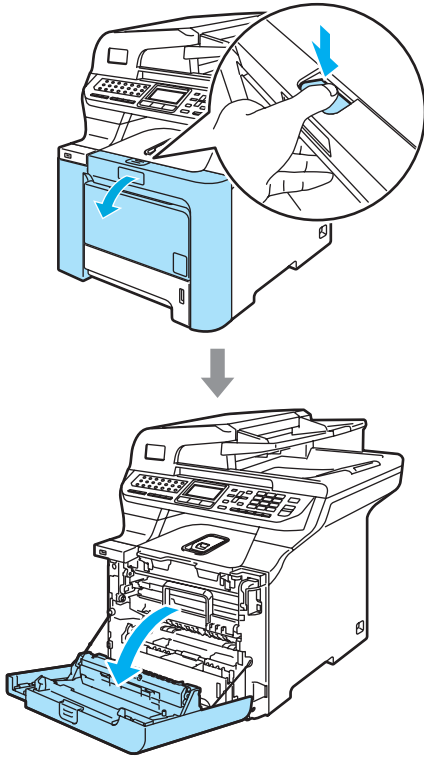

- 2 Hold the green handle of the drum unit. Lift the drum unit up and then pull it out until it stops.

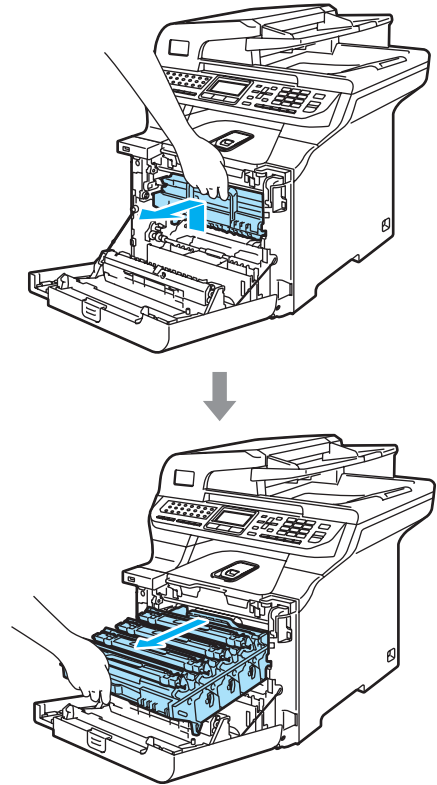

- 3 Release the gray lock lever (1) that is on the left side of the machine. Lift the front of the drum unit and pull the drum unit completely out of the machine using the green handles on the drum unit.

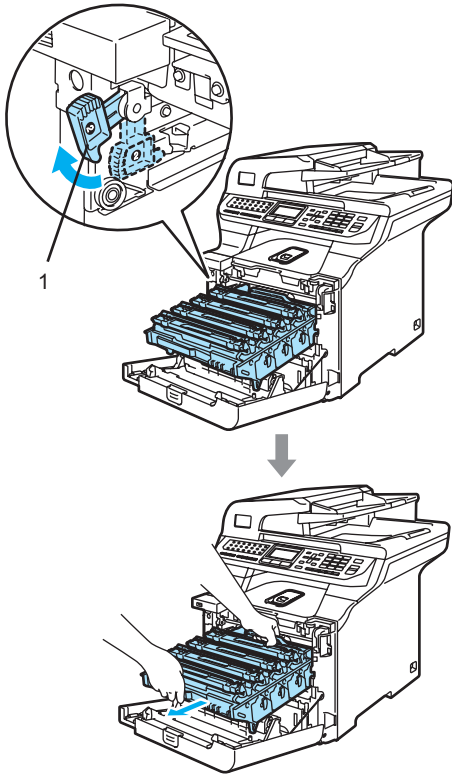

! CAUTION

Hold the handles of drum unit when you carry it. **DO NOT** hold the sides of the drum unit.

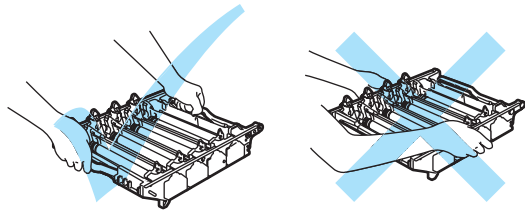

We recommend that you place the drum unit on a clean, flat surface with a piece of disposable paper underneath it in case you accidentally spill or scatter toner.

If toner scatters on your hands or clothes, wipe or wash it off with cold water at once.

To prevent damage to the machine from static electricity, **DO NOT** touch the electrodes shown in the illustration.

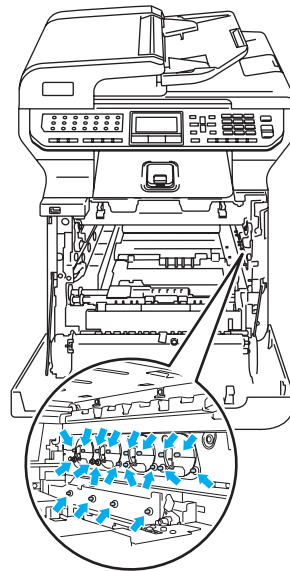

- 4 Hold the green parts of the belt unit with both hands and lift the belt unit up, then pull it out.

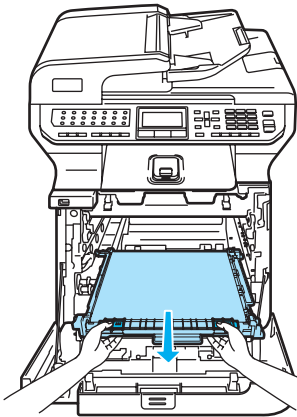
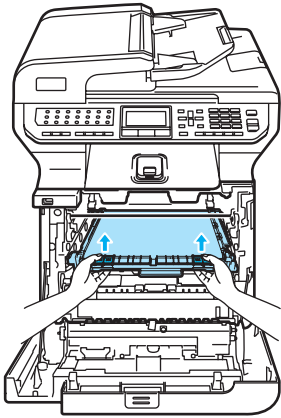

CAUTION

We recommend that you place the belt unit on a clean, flat surface with a piece of disposable paper underneath it in case you accidentally spill or scatter toner.

- 5 Remove the waste toner box from the machine using the green handle.

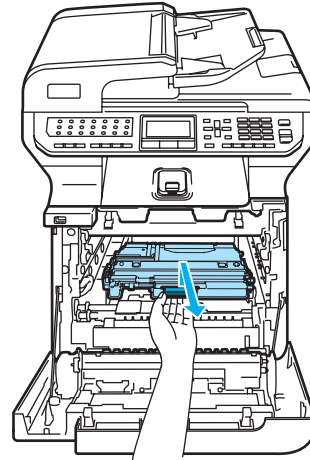

Note

Discard the used waste toner box according to local regulations, keeping it separate from domestic waste. If you have questions, call your local waste disposal office.

- 6 Unpack the new waste toner box and put the new one in the machine using the green handle.

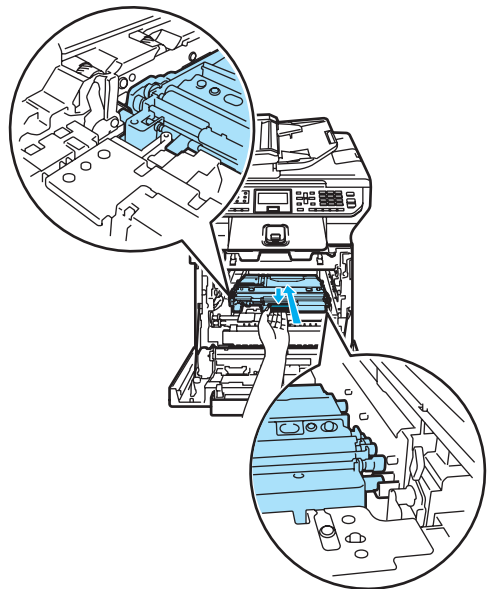

- 7** Put the belt unit back in the machine. Match the ↓ mark on the belt unit to the ↑ mark on the machine. Push down on the green area of the belt unit to lock it in place.

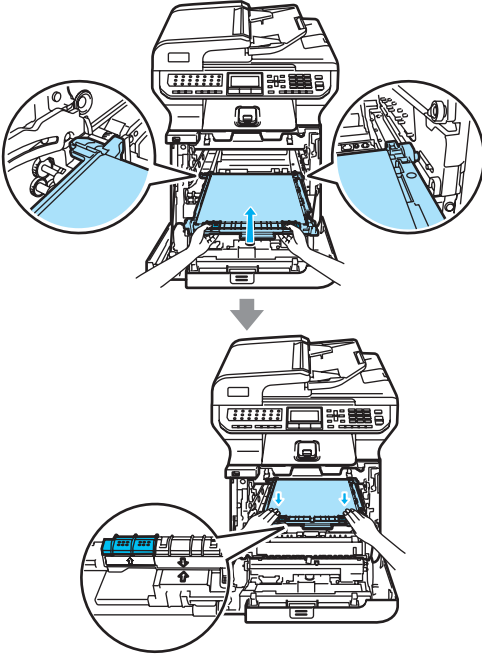

- 8** Put the drum unit back in the machine as follows.

- 1** Make sure that the gray lock lever (1) is in the up position and put the drum unit in the machine. Push down the gray lock lever (1).

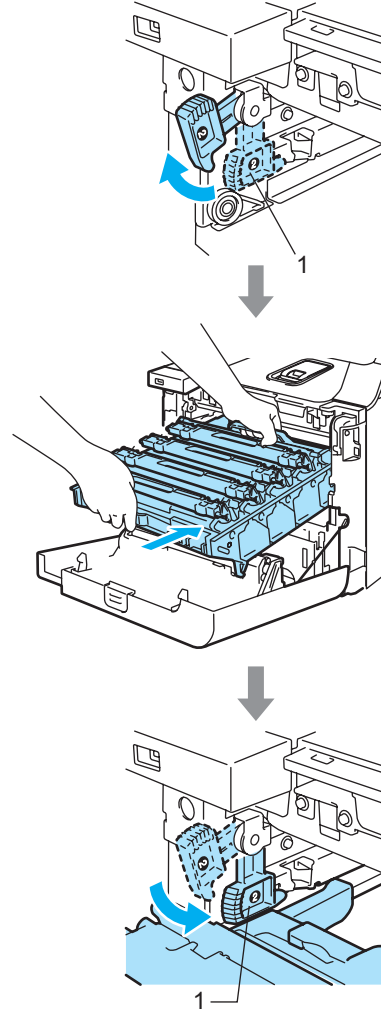



Note

When you put the drum unit in the machine, match the green guides (1) of the drum unit handle to the green arrows (2) on both sides of the machine.

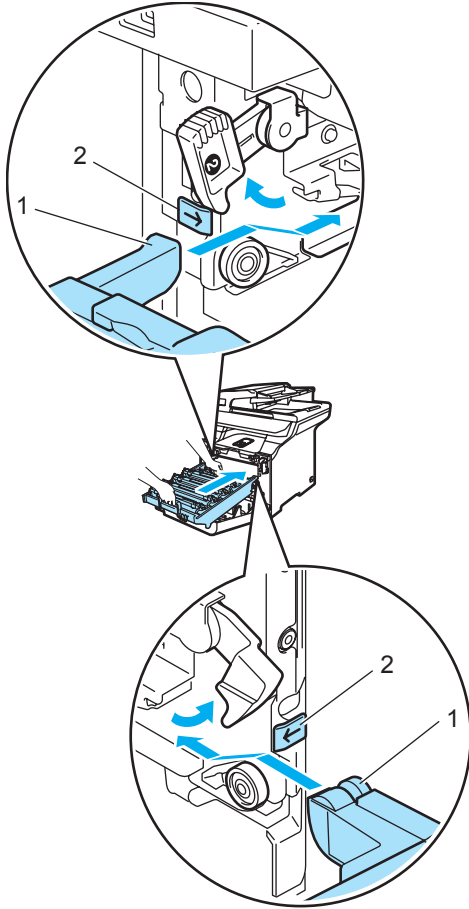

2 Push the drum unit in until it stops.

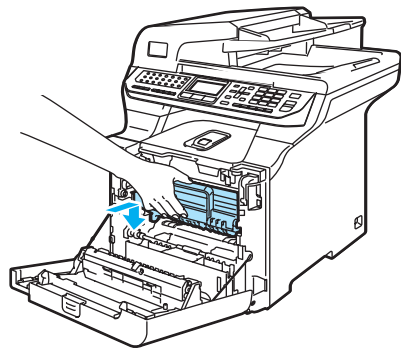
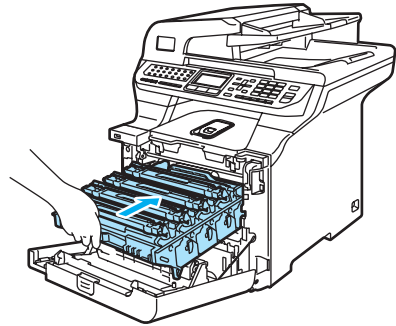

9 Close the front cover of the machine.

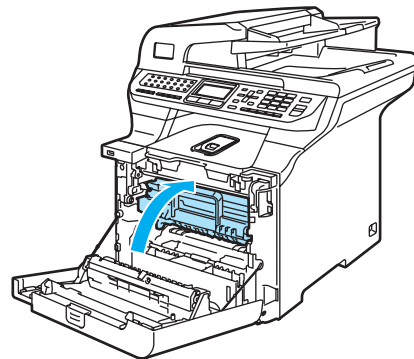

C

Packing and shipping the machine

If for any reason you must move or ship your machine, carefully re-pack the machine in the original packing material to avoid any damage during transport. If you do not pack the machine properly, you could void your warranty. The machine should be adequately insured with the carrier.

If the machine must be shipped, please read the instructions in this section which explains how to properly prepare your machine for transport.

WARNING

Once your machine has been set up and used, we do not recommend that it be moved or shipped unless absolutely necessary.

Color laser printers are complex printing devices. Moving the machine or shipping it without properly removing the installed supplies can result in SEVERE damage to the machine. As a result, your machine may not operate properly afterwards.

Failure to properly prepare the machine for shipping according to the instructions in this section may

VOID YOUR WARRANTY.

To prevent injuries when moving or lifting this machine, make sure at least two people lift the machine together. Be careful not to pinch your fingers when you put the machine down.

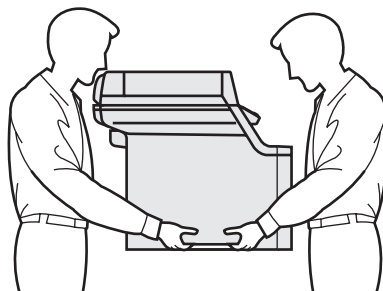

Make sure that you have the following parts for repacking:

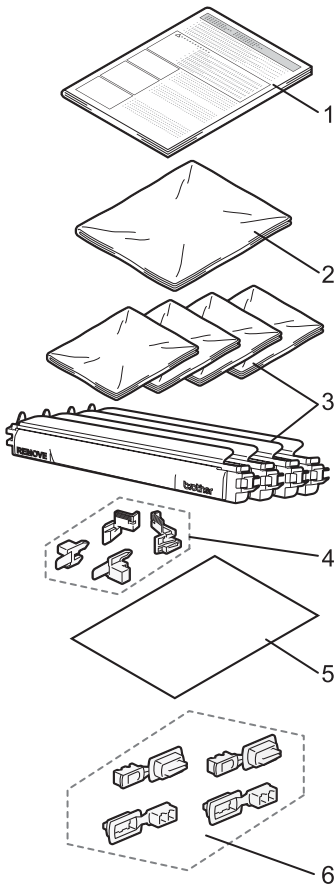

- 1 Insertion sheet for repacking
- 2 Plastic bag for the waste toner box
- 3 Orange protective cover and Plastic bag that the toner cartridge originally came in (4 pieces of each)
- 4 Orange packing material for locking the drum unit and the belt unit (4 pieces)
- 5 A piece of paper (Letter or A4) to protect the belt unit (supplied by the user)
- 6 Joints for attaching cartons (4 pieces)

Repacking the machine

- 1 Turn off the machine's power switch. Unplug the telephone line cord first, disconnect all cables, and then unplug the power cord from the AC power outlet.
- 2 Lift the document cover. Push the scanner lock lever down to lock the scanner.

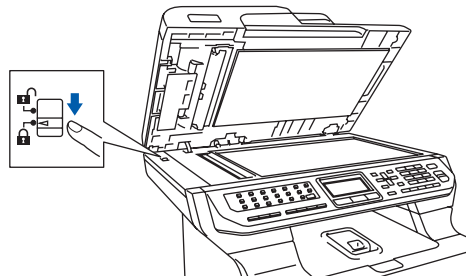

- 3 Press the front cover release button and then open the front cover.

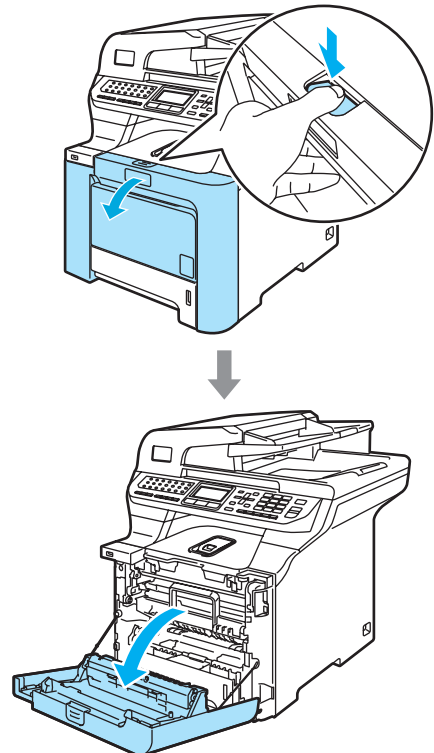

- 4 Hold the green handle of the drum unit. Lift the drum unit up and then pull it out until it stops.

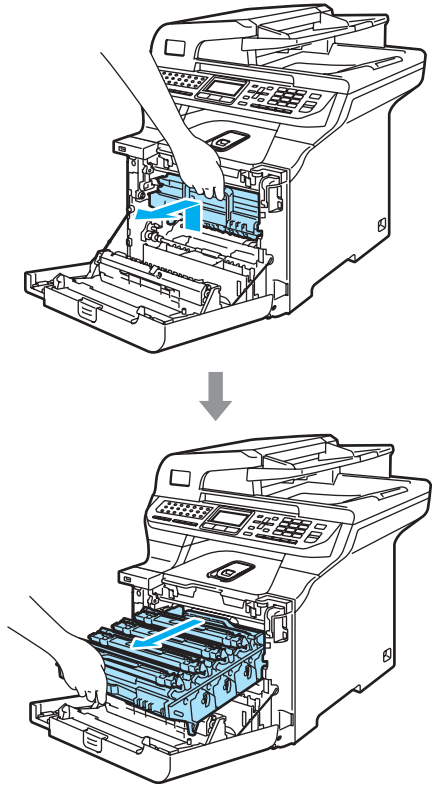

- 5 Release the gray lock lever (1) that is on the left side of the machine. Lift the front of the drum unit and pull the drum unit completely out of the machine using the green handles on the drum unit.

CAUTION

Hold the handles of the drum unit when you carry it. DO NOT hold the sides of the drum unit.

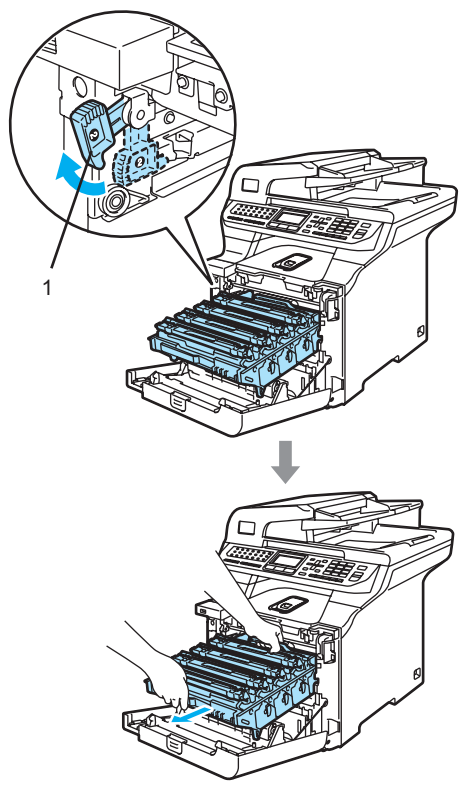
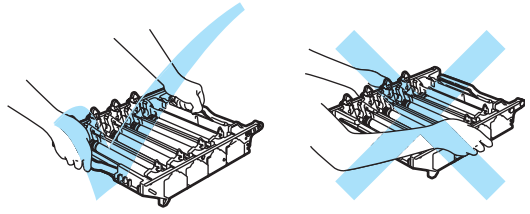

! CAUTION

We recommend that you place the drum unit on a clean, flat surface with a piece of disposable paper underneath it in case you accidentally spill or scatter toner.

- 6 Hold the handle of the toner cartridge and pull it out of the drum unit. Repeat this for all of the toner cartridges.

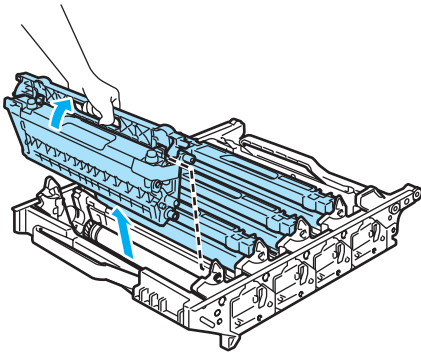

! CAUTION

We recommend that you place the toner cartridges on a clean, flat surface with a piece of disposable paper underneath it in case you accidentally spill or scatter toner.

- 7 Attach the original orange protective cover to each of the toner cartridges. Place each of the toner cartridges into the plastic bag that the cartridge originally came in.

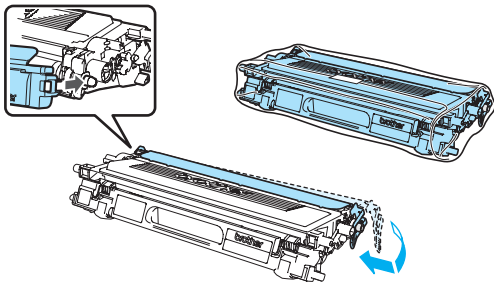

- 8 Hold the green parts of the belt unit with both hands and lift the belt unit up, then pull it out.

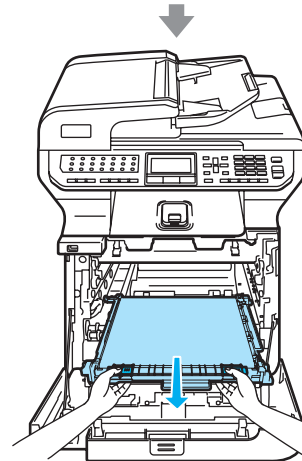
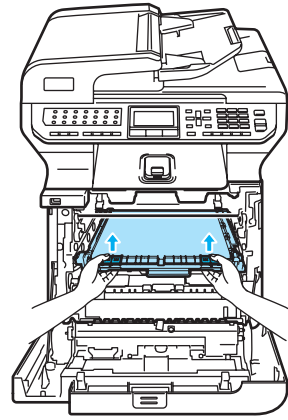

! CAUTION

We recommend that you place the belt unit on a clean, flat surface with a piece of disposable paper underneath it in case you accidentally spill or scatter toner.

- 9 Remove the waste toner box from the machine using the green handle and place it into the plastic bag included in the carton.

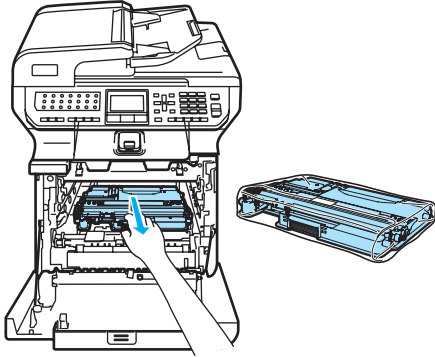

- 10 Put the belt unit back in the machine. Match the ↓ mark on the belt unit to the ↑ mark on the machine. Push down on the green area of the belt unit to lock it in place.

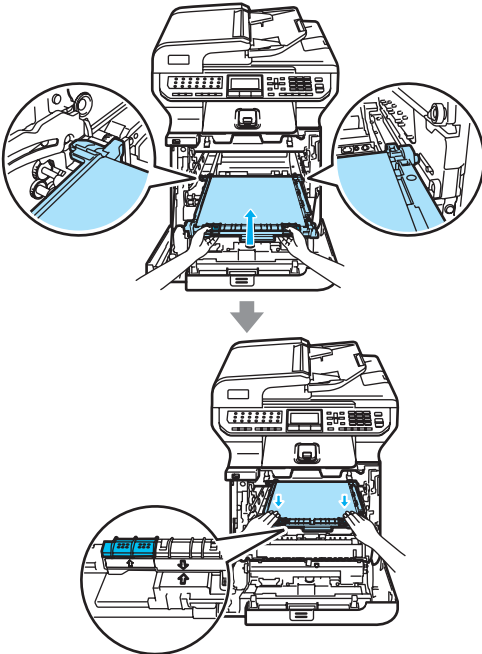

- 11 Insert the original orange packing material for locking the belt unit as shown in the illustration.

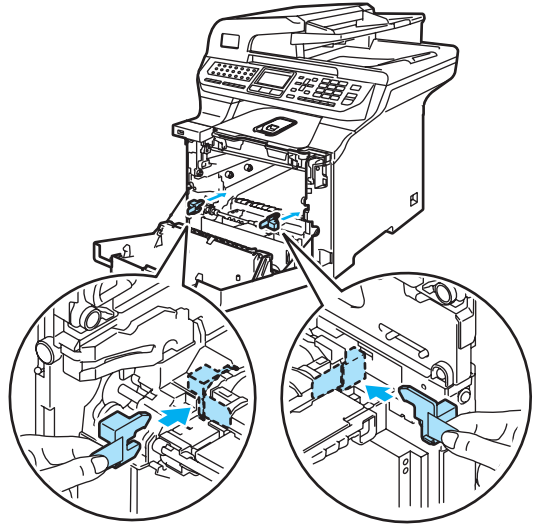

- 12 Put a piece of paper (letter or A4) on the belt unit to prevent damage to the belt unit.

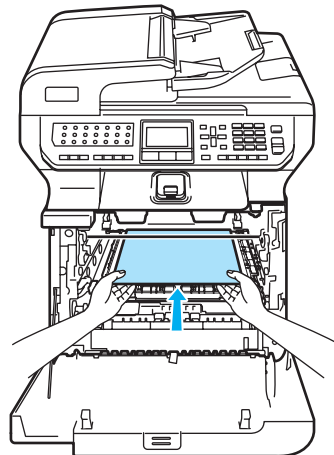

13 Put the drum unit back in the machine as follows.

- 1 Make sure that the gray lock lever (1) is in the up position and put the drum unit in the machine. Push down the gray lock lever (1).

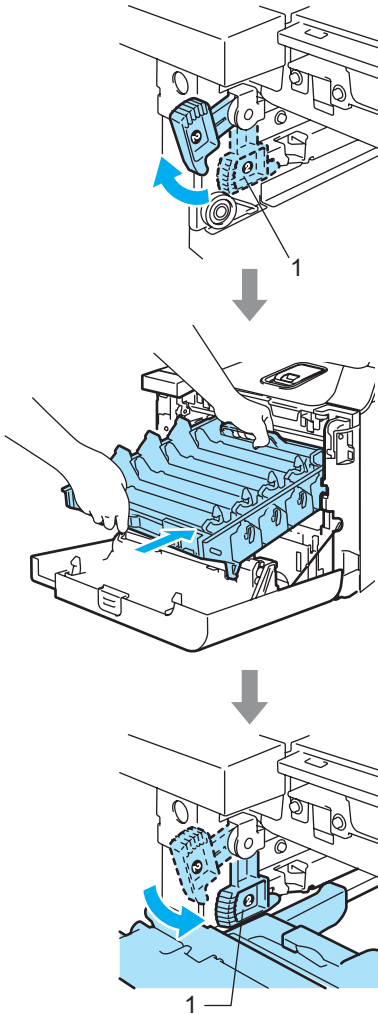

 **Note**

When you put the drum unit in the machine, match the green guides (1) of the drum unit handle to the green arrows (2) on both sides of the machine.

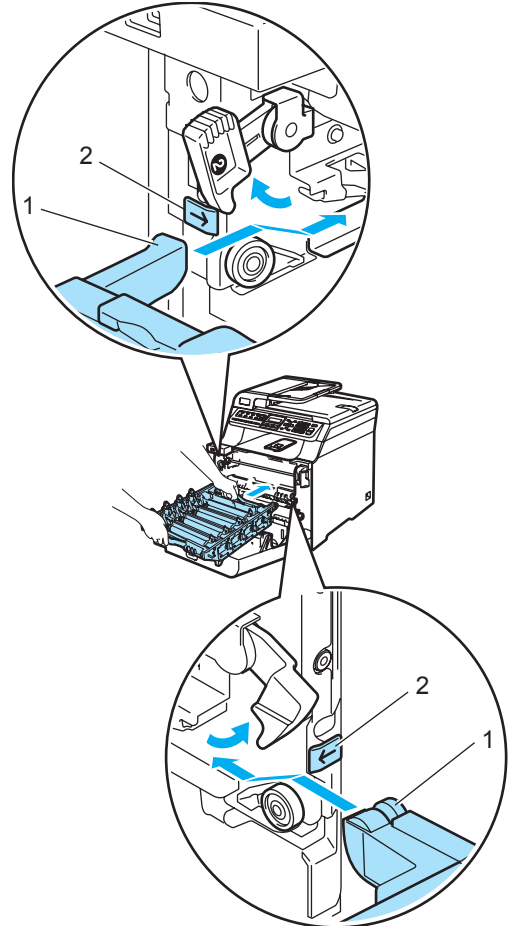

- 2 Push the drum unit back in until it stops.

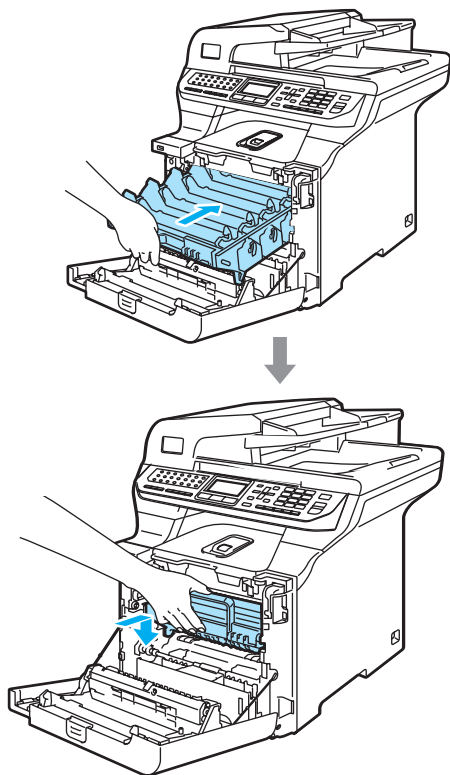

- 14 Insert the original orange packing material for the drum unit until as shown in the illustration, and then close the front cover.

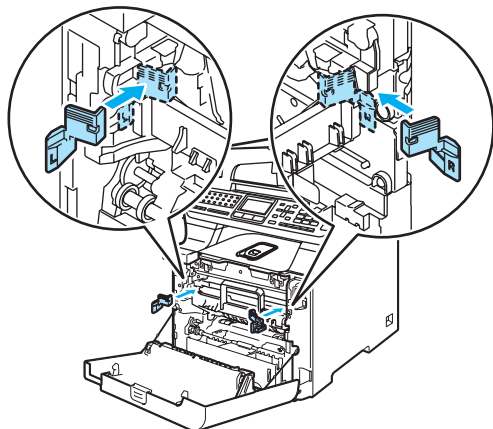

15



Note

We recommend you repack the machine on a table or desk.

Put the styrofoam piece marked "FRONT" (1) into the lower carton (3), so that the arrow cutout (4) points toward it. Put the styrofoam piece marked "REAR" into the lower carton so that the arrow cutout (4) points away from it.

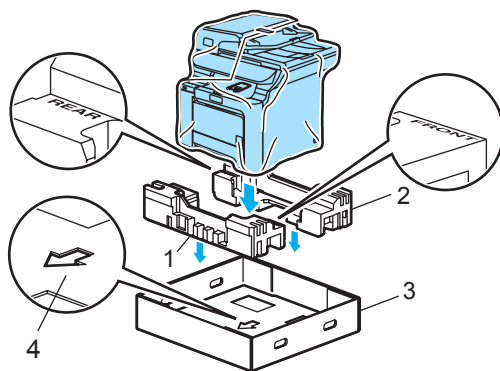

16

Using two people, place the machine into the plastic bag and then into the lower carton, matching the "FRONT" piece to the front of the machine as shown in the illustration in Step 15.

17

As shown in the illustration, fit the two foam pieces marked "FRONT" (4) to the cardboard piece marked "FRONT" (7). Fit the "REAR/L" (5) and "REAR/R" (6) foam pieces to the left and right of the cardboard piece marked "REAR" (8).

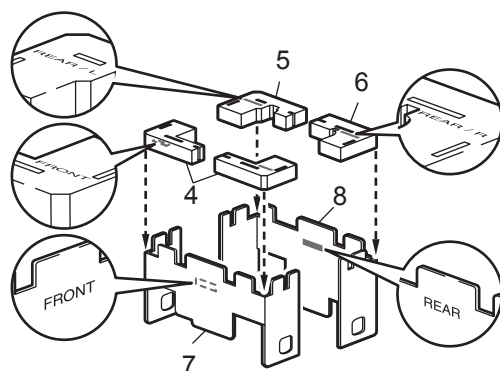

- 18 Put the assembled “FRONT” (1) and “REAR” (2) cardboard pieces in the lower carton at the front and rear of the machine as shown in the illustration. The foam pads should fit closely to the machine to support it.

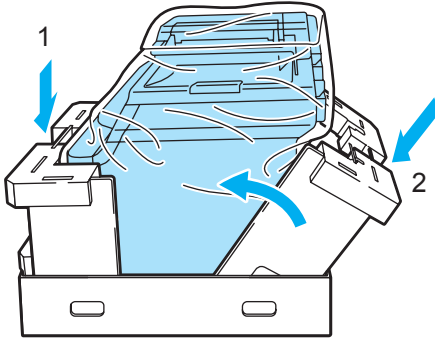

- 19 Place the upper carton (1) over the machine and the lower carton. Match the joint holes (2) of the upper carton to the joint holes (3) of the lower carton.

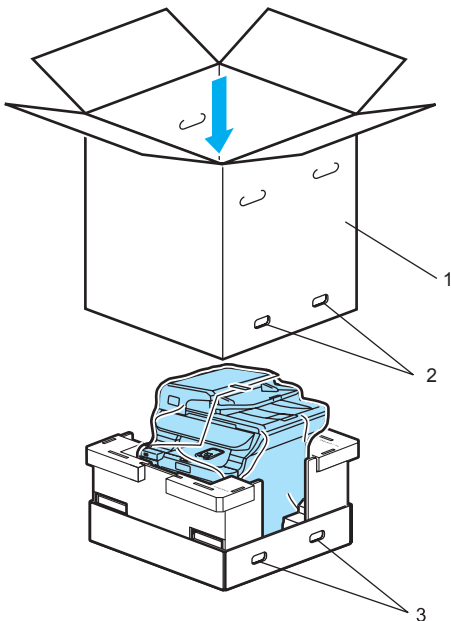

- 20 Put the two styrofoam pieces for the toner cartridges on the top of the machine. Match the right side of the machine to the “RIGHT” mark on one of the styrofoam pieces, and the left side of the machine to the “LEFT” mark on the other styrofoam piece. Put the toner cartridges in the styrofoam.

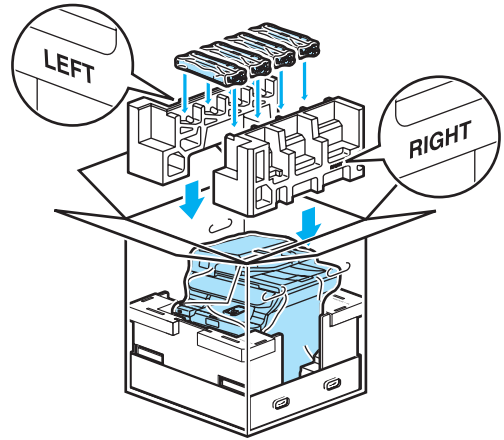

- 21 Put the carton tray (1) on the top. Match the front side of the machine to the Δ marks on the carton tray. Place the waste toner box in the right side of the carton tray.

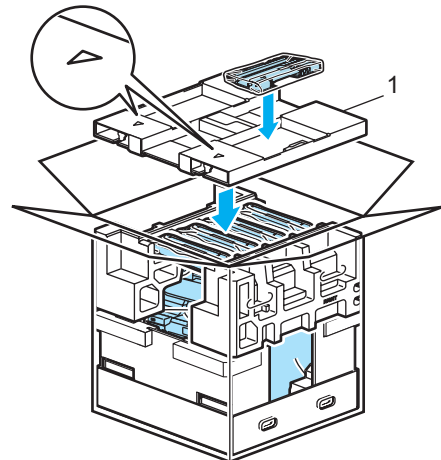

- 22 Put the four joints (1) into the holes of the carton using steps A and B as shown below.

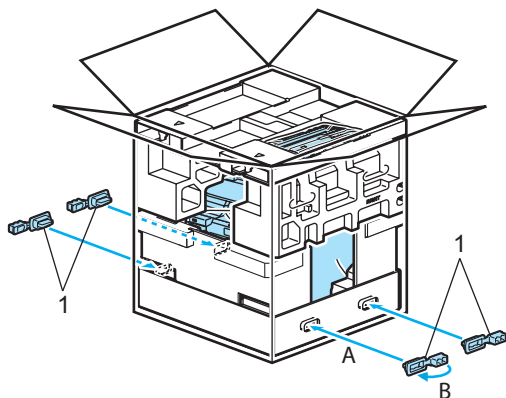

- 23 Close the carton and tape it shut.

Machine information

Checking the serial number

You can see the machine's serial number on the LCD.

- 1 Press **Menu, 8, 1**.

```
81.Serial No.
XXXXXXXXXX
```

- 2 Press **Stop/Exit**.

Checking the page counters

You can see the machine's page counters for copies, printed pages, reports and lists, faxes or a summary total.

- 1 Press **Menu, 8, 2**.

The LCD shows number of pages for Total, Fax/List and Copy.

```
82.Page Counter
▲ Total :XXXXXX
  Fax/List :XXXXXX
▼ Copy :XXXXXX
Select ▲▼ or OK
```

- 2 Press **▲** or **▼** to see number of pages for Print.

```
82.Page Counter
▲ Fax/List :XXXXXX
  Copy :XXXXXX
▼ Print :XXXXXX
Select ▲▼ or OK
```

- 3 Press **▲** or **▼** to choose the option of which you want to see the machine's page counters for color and black & white.
Press **OK**.

```
82.Page Counter
  Total
  Color :XXXXXX
  B&W :XXXXXX
```

- 4 Press **Stop/Exit**.

Checking the remaining life of parts

You can view the remaining life of these parts on the LCD.

- 1 Press **Menu**, **8**, **3**.

```
83.Parts Life
 1.Drum
 2.Belt Unit
 3.PF Kit MP
-----
Select ▲▼ or OK
```

- 2 Press **▲** or **▼** to choose 1.Drum, 2.Belt Unit, 3.PF Kit MP, 4.PF Kit 1, 5.PF Kit 2¹, 6.Fuser or 7.Laser. Press **OK**.

```
83.Parts Life
 1.Drum
-----
Remaining: XX%
```

¹ PF Kit 2 appears only when the optional LT-100CL tray is installed.

- 3 Press **Stop/Exit**.



Note

The life check of a part will be accurate only if that part's life counter was reset when the new part was installed. It will not be accurate if that part's life counter was reset during the life of the used part.

D

Menu and features

On-screen programming

Your machine has been designed to be easy to use. The LCD provides on-screen programming using the menu keys.

We have created step by step on-screen instructions to help you program your machine. Simply follow the steps as they guide you through the menu selections and programming options.

Menu table

You can program your machine by using the *Menu table* on page 206. These pages list the menu selections and options.

Press **Menu** followed by the menu numbers to program your machine.







For example, to set **Beeper volume** to **Low**:

- 1 Press **Menu**, **1**, **4**, **2**.
- 2 Press **▲** or **▼** to choose **Low**.
- 3 Press **OK**.

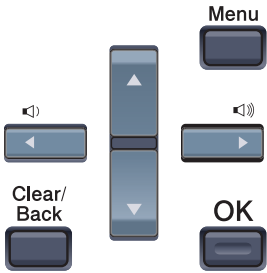
Memory storage

Your menu settings are stored permanently, and in the event of a power failure will *not* be lost. Temporary settings (for example, Contrast, Overseas Mode) *will* be lost. Your machine can store the date and time for approximately 60 hours.

Menu keys

	
	Access the menu.
	Go to the next menu level. Accept an option.
	Exit the menu by pressing repeatedly. Go back to the previous menu level.
	Scroll through the current menu level.
	Go back to the previous menu level or forward to the next menu level.
	Exit the menu.

How to access the menu mode

- 1 Press **Menu**.
- 2 Choose an option.
 - Press **1** for General Setup menu.
 - Press **2** for Fax menu.
 - Press **3** for Copy menu.
 - Press **4** for Printer menu.
 - Press **5** for USB Direct I/F menu.
 - Press **6** for Print Reports menu.
 - Press **7** for LAN menu.
 - Press **8** for Machine Info. menu.
 - Press **9** for Service menu. ¹
 - Press **0** for Initial Setup.

¹ This will appear only when the LCD shows an error message.

You can also scroll through each menu level by pressing ▲ or ▼ for the direction you want.

- 3 Press **OK** when the option you want is highlighted on the LCD.
The LCD will then show the next menu level.
- 4 Press ▲ or ▼ to scroll to your next menu selection.
- 5 Press **OK**.
When you have finished setting an option, the LCD shows *Accepted*.
- 6 Press **Stop/Exit** to return to the top menu.

Menu table

The factory settings are shown in Bold with an asterisk.

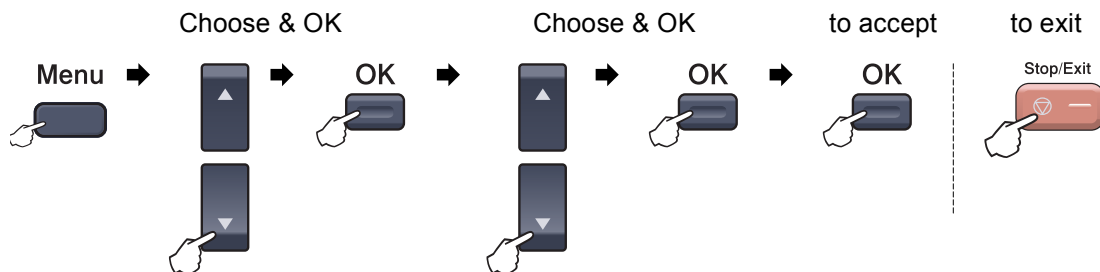

Main Menu	Submenu	Menu Selections	Options	Descriptions	Page
1.General Setup	1.Mode Timer	—	0 Sec 30 Secs 1 Min 2 Mins* 5 Mins Off	Sets the time to return to Fax mode and the time the machine will change from individual user to public user when using Secure Function Lock.	22 32
	2.Paper Type	1.MP Tray	Thin Plain* Thick Thicker Recycled Paper	Sets the type of paper in the MP tray.	22
		2. Tray#1	Thin Plain* Recycled Paper	Sets the type of paper in the paper tray.	22
		3. Tray#2 (This menu only appears if you have the optional tray #2.)	Thin Plain* Recycled Paper	Sets the type of paper in the optional paper tray #2.	22
3.Paper Size	1.MP Tray	A4 Letter* Legal Executive A5 A6 B5 B6 Folio Any	Sets the size of the paper in the MP tray.	23	

Main Menu	Submenu	Menu Selections	Options	Descriptions	Page
1. General Setup (continued)	3. Paper Size (continued)	2. Tray#1	A4 Letter* Legal Executive A5 A6 B5 B6 Folio	Sets the size of the paper in the paper tray.	23
		3. Tray#2 (This menu only appears if you have the optional tray #2.)	A4 Letter* Legal Executive A5 B5 B6 Folio	Sets the size of the paper in the optional paper tray #2.	23
	4. Volume	1. Ring	Off Low Med* High	Adjusts the ring volume.	25
		2. Beeper	Off Low Med* High	Adjusts the volume level of the beeper.	25
		3. Speaker	Off Low Med* High	Adjusts the speaker volume.	25
	5. Auto Daylight	—	On Off*	Changes for Daylight Savings Time automatically.	26
	6. Ecology	1. Toner Save	On Off*	Increases the page yield of the toner cartridge.	26
		2. Sleep Time	(000-240) 005Min*	Conserves power.	26

Main Menu	Submenu	Menu Selections	Options	Descriptions	Page
1.General Setup (continued)	7.Tray Use	1.Copy	Tray#1 Only Tray#2 Only MP Only MP>T1>T2* T1>T2>MP (Tray#2 or T2 appears only if you installed the optional paper tray.)	Selects the tray that will be used for Copy mode.	23
		2.Fax	Tray#1 Only Tray#2 Only MP Only MP>T1>T2 T1>T2>MP* (Tray#2 or T2 appears only if you installed the optional paper tray.)	Selects the tray that will be used for Fax mode.	24
		3.Print	Tray#1 Only Tray#2 Only MP Only MP>T1>T2* T1>T2>MP (Tray#2 or T2 appears only if you installed the optional paper tray.)	Selects the tray that will be used for PC print.	24
	8.LCD Contrast	—	-□□□■+ -□□□■+ -□□■□+* -□■□□+ -■□□□+	Adjusts the contrast of the LCD.	27
	9.Security	1.Setting Lock	—	Stops unauthorized users from changing the machine's current settings.	28
		2.Function Lock	—	Can restrict selected machine operation for up to 25 individual users and all other non-authorized Public users.	29
	0.Document Scan	1.Glass ScanSize	A4/Letter* Legal/Folio	Adjusts the scan area of the scanner glass to the size of the document.	36

Main Menu	Submenu	Menu Selections	Options	Descriptions	Page
1. General Setup (continued)	0. Document Scan (continued)	2. Duplex Scan	Long edge* Short edge	Chooses the duplex scanning format.	35
2. Fax	1. Setup Receive (In Fax mode only)	1. Ring Delay	00 01 02 03 04*	Sets the number of rings before the machine answers in Fax Only or Fax/Tel mode.	46
		2. F/T Ring Time	20 Secs* 30 Secs 40 Secs 70 Secs	Sets the pseudo/double-ring time in Fax/Tel mode.	46
		3. Easy Receive	On* Off	Receives fax messages without pressing Black Start or Color Start .	47
		4. Remote Codes	On* (*51, #51) Off	Allows you to answer all calls at an extension or external telephone and use codes to turn the machine on or off. You can personalize these codes.	57
		5. Auto Reduction	On* Off	Cuts the size of incoming faxes.	48
		6. Print Density	-□□□■+ -□□□□+ -□□■□+* -■□□□+ -■□□□+	Makes printouts darker or lighter.	47
		7. Polling RX	—	Sets up your machine to poll another fax machine.	72
		8. Fax Rx Stamp (B&W only)	On Off*	Prints the received time and date on the top of the received faxes.	49
		9. Duplex	On Off*	Prints received faxes on both sides of the paper.	48
		2. Setup Send (In Fax mode only)	1. Contrast	Auto* Light Dark	Changes the lightness or darkness of faxes you send.

Main Menu	Submenu	Menu Selections	Options	Descriptions	Page
2. Fax (continued)	2. Setup Send (In Fax mode only) (continued)	2. Fax Resolution	Standard* Fine S. Fine (B&W only) Photo (B&W only)	Sets the default resolution for outgoing faxes.	40
		3. Delayed Fax (B&W only)	—	Sets the time of day in 24 hour format that the delayed faxes will be sent.	41
		4. Batch TX (B&W only)	On Off*	Combines delayed faxes going to the same fax number at the same time of day into one transmission.	42
		5. Real Time TX	Next Fax: On Next Fax: Off On Off*	Sends a fax without using the memory.	41
		6. Polled TX	On Off*	Sets up your machine with a document to be retrieved by another fax machine.	73
		7. Coverpg Setup (B&W only)	Next Fax: On Next Fax: Off On Off* Print Sample	Automatically sends a cover page you have programmed.	38
		8. Coverpage Msg (B&W only)	—	Sets up your own comments for the fax cover page.	38
		9. Overseas Mode	On Off*	If you are having difficulty sending faxes overseas, set this to on.	41
	3. Set Quick-Dial	1. One-Touch Dial	—	Stores up to 40 One-Touch Dial numbers, so you can dial by pressing one key (and Black Start or Color Start).	60
		2. Speed-Dial	—	Stores up to 300 Speed-Dial numbers, so you can dial by pressing only a few keys (and Black Start or Color Start).	61
		3. Setup Groups	—	Sets up to 20 Group numbers for Broadcasting.	63

Main Menu	Submenu	Menu Selections	Options	Descriptions	Page
2.Fax (continued)	4.Report Setting	1.Transmission	On On+Image Off* Off+Image	Sets initial setup for Transmission Verification Report and Fax Journal.	74
		2.Journal Period	Off Every 50 Faxes* Every 6 Hours Every 12 Hours Every 24 Hours Every 2 Days Every 7 Days	Sets the interval for automatic printing of the Fax Journal.	74
	5.Remote Fax Opt	1.Fwd/Page/Store (B&W only) (Backup Print)	Off* Fax Forward Paging Fax Storage PC Fax Receive	Sets the machine to forward fax messages, to call your pager, to store incoming faxes in the memory (so you can retrieve them while you are away from your machine), or to send faxes to your PC. If you choose Fax Forward or PC Fax Receive, you can turn on the safety feature Backup Print.	65
		2.Remote Access	---*	Sets your own code for Remote Retrieval.	69
		3.Print Fax	—	Prints incoming faxes stored in the memory.	49
	6.Remaining Jobs	—	—	You can check which jobs are in the memory and lets you cancel scheduled jobs.	42
	0.Miscellaneous	1.Compatibility	High* Normal Basic(for VoIP)	Adjusts the equalization for transmission difficulties. VoIP service providers offer fax support using various standards. If you regularly experience fax transmission errors, choose Basic(for VoIP).	132
		2.Distinctive	Off* Set	Uses the telephone company's Distinctive Ring subscriber service to register the ring pattern with the machine.	51

Main Menu	Submenu	Menu Selections	Options	Descriptions	Page	
3.Copy	1.Quality	—	Auto* Text Photo	You can choose the Copy resolution for your type of document.	79	
	2.Brightness	—	-□□□□■+ -□□□□■+ -□□□□■+* -□□□□■+ -■□□□□+	Adjusts the brightness for copies.	83	
	3.Contrast	—	-□□□□■+ -□□□□■+ -□□□□■+* -□□□□■+ -■□□□□+	Adjusts the contrast for copies.	83	
	4.Color Adjust	1.Red	—	-□□□□■+ -□□□□■+ -□□□□■+* -□□□□■+ -■□□□□+	Adjusts the red color for copies.	83
		2.Green	—	-□□□□■+ -□□□□■+ -□□□□■+* -□□□□■+ -■□□□□+	Adjusts the green color for copies.	
		3.Blue	—	-□□□□■+ -□□□□■+ -□□□□■+* -□□□□■+ -■□□□□+	Adjusts the blue color for copies.	
	4.Printer	1.Emulation	—	Auto* HP LaserJet BR-Script 3	Chooses the emulation mode.	See Software User's Guide on the CD-ROM.
2.Print Options		1.Internal Font	—	Prints a list of the machine's internal fonts.		
		2.Configuration	—	Prints a list of the machine's printer settings.		
		3.Test Print	—	Prints a test page.		

Main Menu	Submenu	Menu Selections	Options	Descriptions	Page	
4. Printer (continued)	3. Duplex	—	Off* On (Long Edge) On (Short Edge)	Enables or disables duplex printing. You can also choose long edge or short edge duplex printing.	<i>See Software User's Guide on the CD-ROM.</i>	
	4. Output Color	—	Auto* Color B&W	Chooses color or black & white printed documents. If you choose Auto , the machine selects a suitable option for the document (color or B&W).		
	5. Reset Printer	1. Reset	—	—		Returns the PCL setting to the default settings.
		2. Exit	—	—		
	6. Calibration	—	Calibrate Reset	Adjusts the color density or returns the color calibration to the factory setting.		
	7. Auto Regist.	1. Registration	1. Start	—		Adjust the print position of each color automatically.
			2. Exit	—		
	7. Auto Regist.	2. Frequency	Low Medium* High Off	Set the interval time you want to carry out the auto registration.		
		8. Manual Regist.	1. Print Chart	—		Print the chart to manually check the registration of the colors.
	2. Set Regist.		1 Magenta Left 2 Cyan Left 3 Yellow Left 4 Magenta Center 5 Cyan Center 6 Yellow Center 7 Magenta Right 8 Cyan Right 9 Yellow Right	Sets the correction value on the chart you printed from Print Chart.		

Main Menu	Submenu	Menu Selections	Options	Descriptions	Page
5.USB Direct I/F	1.Direct Print	1.Paper Size	A4 Letter* Legal Executive A5 A6 B5 B6 Folio	Sets the paper size when printing directly from the USB flash memory drive.	92
		2.Media Type	Thin Plain* Thick Thicker Recycled Paper	Sets the media type when printing directly from the USB flash memory drive.	92
		3.Multiple Page	1in1* 2in1 4in1 9in1 16in1 25in1 1 in 2x2 pages 1 in 3x3 pages 1 in 4x4 pages 1 in 5x5 pages	Sets the page style when printing multiple pages directly from the USB flash memory drive.	92
		4.Orientation	Portrait* Landscape	Sets the page orientation when printing directly from the USB flash memory drive.	92
		5.Collate	On* Off	Enables or disables the page collation when printing directly from the USB flash memory drive.	92
		6.Print Quality	Normal* Fine	Sets the print quality option when printing directly from the USB flash memory drive.	92
		7.PDF Option	Document* Document&Markup Document&Stamps	Sets the PDF option whether to print comments (Markup) or stamps in the PDF file along with the text.	92
		8.Index Print	Simple* Details	Sets the index print option, simple format or details.	92

Main Menu	Submenu	Menu Selections	Options	Descriptions	Page
5.USB Direct I/F (continued)	2.Scan to USB	1.Resolution	Color 150 dpi* Color 300 dpi Color 600 dpi B&W 200 dpi B&W 200x100 dpi	Sets the resolution to send the scanned data to USB flash memory drive.	See <i>Software User's Guide on the CD-ROM.</i>
		2.File Name	—	Enter the file name of the scanned data.	
	3.PictBridge	1.Paper Size	Letter* A4 B5 A5 B6 A6	Sets the paper size when printing data from a camera with using PictBridge.	88
		2.Orientation	Letter A4 B5 A5 B6 A6 Then, you will choose: Portrait* Landscape	Sets the page orientation when printing data from a camera using PictBridge. If you choose the paper size Letter, A4 or B5, Portrait will be chosen. If you choose A5, B6 or A6, Landscape will be chosen.	88
		3.Date & Time	On Off*	Prints the date and time the photo is being taken on the photo.	88
		4.File Name	On Off*	Prints the file name of the data on the photo.	88
		5.Print Quality	Normal* Fine	Sets the print quality option when printing data from a camera using PictBridge.	88
6. Print Reports	1.Transmission	1.View on LCD	—	You can view the Transmission Verification Report for your last 200 outgoing faxes and print the last report.	75
		2.Print Report	—		
	2.Help List	—	—	Prints the Help List so you can see at-a-glance how to quickly program your machine.	75

Main Menu	Submenu	Menu Selections	Options	Descriptions	Page
6. Print Reports (continued)	3. Tel Index List	1. Numeric	—	Lists name and numbers stored in the One-Touch and Speed-Dial memory, in numerical or alphabetical order.	75
		2. Alphabetic	—		
	4. Fax Journal	—	—	Lists information about your last 200 incoming and outgoing faxes. (TX means Transmit. RX means Receive.)	75
	5. User Settings	—	—	Lists your settings.	75
	6. Network Config	—	—	Lists your Network settings.	75

Main Menu	Submenu	Menu Selections	Options	Descriptions	Page	
7. LAN	1. Wired	1. TCP/IP	1. BOOT Method	Auto* Static RARP BOOTP DHCP	Chooses the BOOT method that best suits your needs.	See <i>Network User's Guide on the CD-ROM.</i>
			2. IP Address	[000-255]. [000-255]. [000-255]. [000-255]	Enter the IP address.	
			3. Subnet Mask	[000-255]. [000-255]. [000-255]. [000-255]	Enter the Subnet mask.	
			4. Gateway	[000-255]. [000-255]. [000-255]. [000-255]	Enter the Gateway address.	
			5. Node Name	BRNXXXXXX	Enter the Node name.	
			6. WINS Config	Auto* Static	Chooses the WINS configuration mode.	
			7. WINS Server	(Primary) 000.000.000.000 (Secondary) 000.000.000.000	Specifies the IP address of the primary or secondary WINS server.	

Main Menu	Submenu	Menu Selections	Options	Descriptions	Page		
7. LAN (continued)	1. Wired (continued)	1. TCP/IP (continued)	8. DNS Server	(Primary) 000.000.000.000 (Secondary) 000.000.000.000	Specifies the IP address of the primary or secondary DNS server.	See <i>Network User's Guide on the CD-ROM.</i>	
			9. APIPA	On* Off	Automatically allocates the IP address from the link-local address range.		
			0. IPv6	On Off*	Enable or Disable the IPv6 protocol. If you want to use the IPv6 protocol, visit http://solutions.brother.com for more information.		
		2. Ethernet	—	Auto* 100B-FD 100B-HD 10B-FD 10B-HD	Chooses the Ethernet link mode.		
		3. Set to Default	1. Reset	—	Restore the wired network setting to factory default.		
			2. Exit	—			
		4. Wired Enable		On* Off	Enable or Disable the Wired LAN manually.		
		2. WLAN	1. TCP/IP	1. BOOT Method	Auto* Static RARP BOOTP DHCP		Chooses the BOOT method that best suits your needs.
				2. IP Address	[000-255]. [000-255]. [000-255]. [000-255]		Enter the IP address.
				3. Subnet Mask	[000-255]. [000-255]. [000-255]. [000-255]		Enter the Subnet mask.
	4. Gateway			[000-255]. [000-255]. [000-255]. [000-255]	Enter the Gateway address.		
	5. Node Name			BRWXXXXXX	Enter the Node name.		

Main Menu	Submenu	Menu Selections	Options	Descriptions	Page	
7. LAN (continued)	2. WLAN (continued)	1. TCP/IP (continued)	6. WINS Config	Auto* Static	Chooses the WINS configuration mode.	See Network User's Guide on the CD-ROM.
			7. WINS Server	(Primary) 000.000.000.000 (Secondary) 000.000.000.000	Specifies the IP address of the primary or secondary WINS server.	
			8. DNS Server	(Primary) 000.000.000.000 (Secondary) 000.000.000.000	Specifies the IP address of the primary or secondary DNS server.	
			9. APIPA	On* Off	Automatically allocates the IP address from the link-local address range.	
			0. IPv6	On Off*	Enable or Disable the IPv6 protocol. If you want to use the IPv6 protocol, visit http://solutions.brother.com for more information.	
		2. Setup Wizard	—	—	You can configure your print server.	
		3. SecurEasy Setup	—	—	You can configure the wireless network easily.	
		4. WLAN Status	1. Status	Active (11b) Active (11g) Wired LAN Active WLAN OFF Connection NG	You can see the current wireless network status.	
			2. Signal	Strong Medium Weak None	You can see the current wireless network signal strength.	
			3. SSID	—	You can see the current SSID.	
			4. Comm. Mode	Ad-hoc Infrastructure	You can see the current Communication Mode.	
		5. Set to Default	1. Reset	—	Restore the wireless network setting to factory default.	
			2. Exit	—		
		6. WLAN Enable	—	On Off*	Enable or Disable the wireless LAN manually.	

Main Menu	Submenu	Menu Selections	Options	Descriptions	Page	
7. LAN (continued)	3. Setup IFAX	1. Setup Internet	1. Mail Address	—	Enter the mail address. (Up to 60 characters)	See <i>Network User's Guide on the CD-ROM.</i>
			2. SMTP Server	Name? (up to 64 characters) IP Address? [000-255]. [000-255]. [000-255]. [000-255]	Enter the SMTP server address.	
			3. SMTP Port	[00001-65535]	Enter the POP3 port number.	
			4. Auth. for SMTP	None* SMTP-AUTH POP bef. SMTP	Selects the security method for E-mail notification.	
			5. POP3 Server	Name? (up to 30 characters) IP Address? [000-255]. [000-255]. [000-255]. [000-255]	Enter the POP3 server address.	
			6. POP3 Port	[00001-65535]	Enter the POP3 port number.	
			7. Mailbox Name	—	Enter the mail box name. (Up to 32 characters)	
			8. Mailbox Pwd	—	Enter the password to login to the POP3 server. (Up to 32 characters)	
			9. APOP	On Off*	Enables or disables APOP.	
		2. Setup Mail RX	1. Auto Polling	On* Off	Automatically checks the POP3 server for new messages.	
			2. Poll Frequency	10 Min	Sets the interval for checking for new messages on the POP3 server.	
			3. Header	All Subject+From+To None*	Selects the contents of the mail header to be printed.	
			4. Del Error Mail	On* Off	Deletes error mails automatically.	
			5. Notification	On MDN Off*	Receives notification messages.	
		3. Setup Mail TX	1. Sender Subject	—	Displays the subject that is attached to the Internet Fax data.	

Main Menu	Submenu	Menu Selections		Options	Descriptions	Page
7. LAN (continued)	3. Setup IFAX (continued)	3. Setup Mail TX (continued)	2. Size Limit	On Off*	Limits the size of E-mail documents.	See Network User's Guide on the CD-ROM.
			3. Notification	On Off*	Sends notification messages.	
		4. Setup Relay	1. Rly Broadcast	On Off*	Relays a document to another fax machine.	
			2. Relay Domain	Relay	Registers the Domain name.	
			3. Relay Report	On Off*	Prints the Relay Broadcast Report.	
	4. Scan to E-mail	—	Color 150 dpi* Color 300 dpi Color 600 dpi B&W 200 dpi B&W 200x100 dpi	(If you chose color option) PDF* JPEG	Chooses the file format to send the scanned data via e-mail.	
				(If you chose B&W option) PDF* TIFF		
	5. Scan to FTP	—	Color 150 dpi* Color 300 dpi Color 600 dpi B&W 200 dpi B&W 200x100 dpi	(If you chose color option) PDF* JPEG	Chooses the file format to send the scanned data via FTP.	
				(If you chose B&W option) PDF* TIFF		
	6. Fax to Server	—	—	On Off*	You can store a prefix/suffix address in the machine and can send a document from a fax server system.	
7. Time Zone	—	—	UTC XXX:XX	Sets the time zone for your country.		
0. Factory Reset	1. Reset	—	1. Yes 2. No	Restores all network settings to factory default.		
	2. Exit	—	—			

Main Menu	Submenu	Menu Selections	Options	Descriptions	Page
8.Machine Info.	1.Serial No.	—	—	You can check the serial number of your machine.	202
	2.Page Counter	—	Total Fax/List Copy Print	You can check the number of total pages the machine has printed during its life.	202
	3.Parts Life	1.Drum 2.Belt Unit 3.PF Kit MP 4.PF Kit 1 5.PF Kit 2 6.Fuser 7.Laser	—	You can check the percentage of a machine part's life that remains available. PF Kit 2 appears only when the optional LT-100CL tray is installed.	203
	4.Reset Menu	—	Drum Belt Unit PF Kit MP PF Kit 1 PF Kit 2	Resets the machine part's life counter. Appears when you replace the machine part. PF Kit 2 appears only when the optional LT-100CL tray is installed.	177 183
0.Initial Setup	1.Receive Mode	—	Fax Only* Fax/Tel External TAD Manual	Chooses the receive mode that best suits your needs.	44
	2.Date & Time	—	—	Puts the date and time on the LCD and in headings of faxes you send.	See <i>Quick Setup Guide.</i>
	3.Station ID	—	Fax: Tel: Name:	Sets your name and fax number to appear on each page you fax.	
	4.Tone/Pulse (in Canada)	—	Tone* Pulse	Chooses the dialing mode.	
	4.Dial Tone (in USA) 5.Dial Tone (in Canada)	—	Detection No Detection*	You can shorten the dial tone detect pause.	132
	5.Dial Prefix (in USA) 6.Dial Prefix (in Canada)	—	On Off*	Sets a prefix number that will always be added before the fax number every time you dial.	27
	0.Local Language (in Canada)	—	English* French	Allows you to change the LCD language for your country.	See <i>Quick Setup Guide.</i>

Entering text

When setting certain menu selections, such as the Station ID, you will need to type text characters. The dial pad keys have letters printed on them. The keys: **0**, **#** and ***** do *not* have printed letters because they are used for special characters.

Press the appropriate dial pad key the required number of times to access the characters below:

- For setting an E-mail address, Scan to FTP menu options, and Setup IFAX menu options
(Menu, 7, 3)

Press Key	one time	two times	three times	four times	five times	six times	seven times	eight times
1	@	.	/	1	@	.	/	1
2	a	b	c	A	B	C	2	a
3	d	e	f	D	E	F	3	d
4	g	h	i	G	H	I	4	g
5	j	k	l	J	K	L	5	j
6	m	n	o	M	N	O	6	m
7	p	q	r	s	P	Q	R	S
8	t	u	v	T	U	V	8	t
9	w	x	y	z	W	X	Y	Z

- For setting other menu selections

Press Key	one time	two times	three times	four times
2	A	B	C	2
3	D	E	F	3
4	G	H	I	4
5	J	K	L	5
6	M	N	O	6
7	P	Q	R	S
8	T	U	V	8
9	W	X	Y	Z

Inserting spaces

To enter a space in a fax number, press ► once between numbers. To enter a space in a name, press ► twice between characters.

Making corrections

If you entered a letter incorrectly and want to change it, press ◀ to move the cursor to the incorrect character, and then press **Clear/Back**.

Repeating letters

To enter a character on the same key as the previous character, press ► to move the cursor right before pressing the key again.

Special characters and symbols

Press *****, **#** or **0**, then press **◀** or **▶** to move the cursor to the symbol or character you want. Press **OK** to choose it. The symbols and characters below will appear depending on your menu selection.

Press *	for	(space) ! " # \$ % & ' () * + , - . / €
Press #	for	: ; < = > ? @ [] ^ _ ¥ ~ ` { }
Press 0	for	Á À Ã Ä Ç È É Ê Ë Ì Í Î Ï Ó Ô Õ Ö Ø Ù Ú Û Ü

General

Memory Capacity	128 MB
ADF (automatic document feeder)	Up to 50 pages (Staggered) [20 lb (80 g/m ²) Duplex, up to Letter size Recommended Environment for Best Results: Temperature: 68° F to 86° F (20 to 30° C) Humidity: 50% - 70% Paper: Xerox 4200 (20 lb/Letter)
Paper Tray	250 Sheets [20 lb (80 g/m ²)]
Paper Tray 2 (option)	500 Sheets [20 lb (80 g/m ²)]
Printer Type	Laser
Print Method	Electrophotography by semiconductor laser beam scanning
LCD (liquid crystal display)	22 characters × 5 lines
Power Source	110-120 V AC 50/60 Hz
Power Consumption	Peak: Average 1200 W Copying: Average 515 W Sleep: Average 38 W Standby: Average 100 W

Dimensions

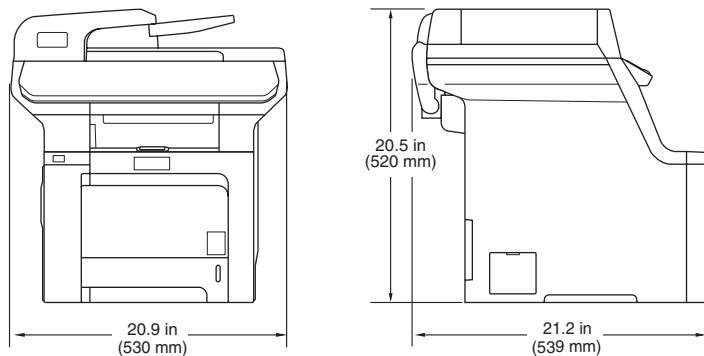

Weight

Without Drum/Toner Unit: 73.2 lb (33.3 kg)

Noise level	Sound power	
	Operating (Copying):	LWAd = 6.9 Bell
	Standby:	LWAd = 4.4 Bell
	Sound pressure	
Temperature	Operating (Copying):	LpAm = 54.5 dBA
	Standby:	LpAm = 30 dBA
	Operating:	50° F to 90.5° F (10 to 32.5° C)
	Storage:	41° F to 95° F (5 to 35° C)
Humidity	Operating:	20 to 80% (without condensation)
	Storage:	10 to 90% (without condensation)

Print media

Paper Input	Paper Tray	
	■ Paper Type:	Plain paper, Thin paper or Recycled paper
	■ Paper Size:	Letter, A4, B5 (ISO), A5, B6 (ISO), A6, Executive, Legal and Folio
	■ Paper Weight:	16 to 28 lb (60 to 105 g/m ²)
	■ Maximum paper tray capacity:	Up to 250 sheets of 20 lb (80 g/m ²) plain paper

Multi-purpose tray (MP tray)

■ Paper Type:	Plain paper, Thin paper, Thick paper, Recycled paper, Bond paper, Envelopes or Labels
■ Paper Size:	Width: 2.75 to 8.5 in. (69.9 to 215.9 mm) Length: 4.57 to 16 in. (116.0 to 406.4 mm)
■ Paper Weight:	16 to 43 lb (60 to 163 g/m ²)
■ Maximum paper tray capacity:	Up to 50 sheets of 20 lb (80 g/m ²) plain paper Up to 3 envelopes

Paper Tray 2 (option)

■ Paper Type:	Plain paper, Thin paper or Recycled paper
■ Paper Size:	Letter, A4, B5 (ISO), A5, B6 (ISO), Executive, Legal and Folio
■ Paper Weight:	16 to 28 lb (60 to 105 g/m ²)
■ Maximum paper tray capacity:	Up to 500 sheets of 20 lb (80 g/m ²) plain paper

Paper Output Up to 150 sheets (face down print delivery to the output paper tray)

Duplex	■ Paper Size	Letter, Legal and Folio
	■ Manual Duplex	Yes
	■ Automatic Duplex	Yes

Fax

Compatibility	ITU-T Group 3
Duplex Fax (Receive)	Yes
Coding System	MH/MR/MMR/JBIG/JPEG
Modem Speed	Automatic Fallback: 33,600 bps
Single-Sided Document Size	ADF Width: 5.8 to 8.5 in. (147.3 to 215.9 mm)
	ADF Height: 5.8 to 14 in. (147.3 to 356 mm)
	Scanner Glass Width: Max. 8.5 in. (215.9 mm)
	Scanner Glass Height: Max. 14 in. (355.6 mm)
2-Sided (Duplex) Document Size	ADF Width: 5.8 to 8.5 in. (147.3 to 215.9 mm)
	ADF Height: 5.8 to 11.7 in. (147.3 to 297.0 mm)
Scanning Width	Max. 8.2 in. (208 mm)
Printing Width	Max. 8.2 in. (208 mm)
Gray Scale	256 levels
Polling Types	Standard, Sequential
Contrast Control	Automatic/Light/Dark (manual setting)
Resolution	Horizontal: 203 dot/inch (8 dot/mm)
	Vertical
	■ Standard: 98 line/in. (3.85 line/mm) (Black) 196 line/in. (7.7 line/mm) (Color)
	■ Fine: 196 line/in. (7.7 line/mm) (Black) 196 line/in. (7.7 line/mm) (Color)
	■ Photo: 196 line/in. (7.7 line/mm) (Black) ■ Superfine: 392 line/in. (15.4 line/mm) (Black)
One-Touch Dial	40 (20 × 2)
Speed-Dial	300 stations
Groups	Up to 20
Broadcasting	390 stations (B&W only)
Automatic Redial	Yes, 1 time after 5 minutes
Auto Answer	0, 1, 2, 3 or 4 rings
Communication Source	Public switched telephone network
Memory Transmission	Up to 500 ¹ / ₄₀₀ ² pages
Out of Paper Reception	Up to 500 ¹ / ₄₀₀ ² pages

¹ 'Pages' refers to the 'Brother Standard Chart No. 1' (a typical business letter, Standard resolution, JBIG code). Specifications and printed materials are subject to change without prior notice.

² 'Pages' refers to the 'ITU-T Test Chart #1' (a typical business letter, Standard resolution, JBIG code). Specifications and printed materials are subject to change without prior notice.

Copy

Copy Speed	Up to 17 pages/minute (Letter size) (Black) ^{1 2} Up to 17 pages/minute (Letter size) (Color) ^{1 2}
Copy Speed for Duplex Copying	Up to 7 sides/minute (3.5 sheet/minute) (Letter size) (Black) ^{1 2} Up to 7 sides/minute (3.5 sheet/minute) (Letter size) (Color) ^{1 2}
Color/Monochrome	Yes/Yes
Single-Sided Document Size	ADF Width: 5.8 to 8.5 in. (148 to 215.9 mm) ADF Height: 5.8 to 14 in. (148 to 355.6 mm) Scanner Glass Width: Max. 8.5 in. (215.9 mm) Scanner Glass Height: Max. 14 in. (355.6 mm) Copy Width: Max. 8.26 in. (210 mm)
2-Sided (Duplex) Document Size	ADF Width: 5.8 to 8.5 in. (147.3 to 215.9 mm) ADF Height: 5.8 to 11.7 in. (147.3 to 297.0 mm)
Multiple Copies	Stacks or Sorts up to 99 pages
Reduce/Enlarge	25% to 400% (in increments of 1%)
Resolution	Up to 1200 × 600 dpi ³
First Copy Out Time	Approx. 21 seconds (Black) ^{4 5} Approx. 23 seconds (Color) ^{4 5}

¹ The copy speed may change depending on the type of document you copy.

² From the standard paper tray and optional paper tray.

³ When making a B&W copy from the scanner glass in text quality mode at the 25 to 150% ratio.

⁴ First copy out time may change if the machine is calibrating or registering itself.

⁵ First copy out time may vary due to scanner lamp warm up time.

Scan

Color/Monochrome	Yes/Yes
Duplex Scanning	Yes
TWAIN Compliant	Yes (Windows® 2000 Professional/XP/ XP Professional x64 Edition/Windows Vista®) Mac OS® X 10.2.4 or greater
WIA Compliant	Yes (Windows® XP/Windows Vista®)
Color Depth	24 bit color
Resolution	Up to 19200 × 19200 dpi (interpolated) ¹ Up to 1200 × 2400 dpi (optical) ² Up to 1200 × 600 dpi (optical) ³
Single-Sided Document Size	ADF Width: 5.8 to 8.5 in. (148.0 to 215.9 mm) ADF Height: 5.8 to 14 in. (148.0 to 355.6 mm) Scanner Glass Width: Max. 8.5 in. (215.9 mm) Scanner Glass Height: Max. 14 in. (355.6 mm)
Scanning Width	Max. 8.26 in. (210 mm)
2-Sided (Duplex) Document Size	ADF Width: 5.8 to 8.5 in. (148.0 to 215.9 mm) ADF Height: 5.8 to 11.7 in. (148.0 to 297.0 mm)
Gray Scale	256 levels

¹ Maximum 1200 × 1200 dpi scanning with the WIA driver in Windows® XP/Windows Vista® (resolution up to 19200 × 19200 dpi can be chosen by using the Brother scanner utility)

² When using the scanner glass

³ When using the ADF

Print

Emulations	PCL6 BR-Script (PostScript®) Level 3
Printer Driver	Host-Based Driver for Windows® 2000 Professional/ XP/XP Professional x64 Edition/Windows Vista®/ Windows Server® 2003 (print only via network) BR-Script (PPD file) for Windows® 2000 Professional/ XP/XP Professional x64 Edition/Windows Vista® Macintosh® Printer Driver for Mac OS® X 10.2.4 or greater BR-Script (PPD file) for Mac OS® X 10.2.4 or greater
Resolution	600 × 600 dpi, 2400 dpi (2400 × 600 dpi)
Print Speed	Up to 21 pages/minute (Letter size) (Black) ^{1 2} Up to 21 pages/minute (Letter size) (Color) ^{1 2}
Print Speed for Duplex Printing	Up to 7 sides/minute (3.5 pages) (Black) Up to 7 sides/minute (3.5 pages) (Color)
First Print Out Time	Less than 16 seconds (Black) ³ Less than 17 seconds (Color) ³

¹ The printing speed may change depending on the type of document you print.

² From the standard paper tray and optional paper tray.

³ First print out time may change if the machine is calibrating or registering itself.

Interfaces

USB	Use a USB 2.0 interface cable that is no longer than 6 feet (2.0 m). ^{1 2}
LAN cable	Use an Ethernet UTP cable category 5 or greater.
Wireless LAN	Your machine supports IEEE 802.11b/g wireless communication with your wireless LAN using Infrastructure mode or a wireless Peer-to-Peer connection in Ad-hoc mode.

¹ Your machine has a Hi-Speed USB 2.0 interface. The machine can also be connected to a computer that has a USB 1.1 interface.

² Third party USB ports are not supported.

PictBridge

Compatibility	Supports the Camera & Imaging Products Association PictBridge standard CIPA DC-001. Visit http://www.cipa.jp/pictbridge for more information.
Interface	USB direct interface

Direct print feature

Compatibility	PDF version 1.6 ¹ , JPEG, Exif + JPEG, PRN (created by MFC-9840CDW printer driver), TIFF (scanned by all Brother MFC or DCP models), PostScript ^{®3™} (created by MFC-9840CDW BR-Script 3 printer driver).
----------------------	--

¹ JBIG2 image files, JPEG2000 image files and layered files are not supported.

Computer requirements

Minimum System Requirements and Supported PC Software Functions								
Computer Platform & Operating System Version		Supported PC Software Functions	PC Interface	Processor Minimum Speed	Minimum RAM	Recommended RAM	Available Hard Disk Space	
							For Drivers	For Applications
Windows® Operating System	Windows® 2000 Professional ⁴	Printing, PC Fax ³ , Scanning	USB, Ethernet, Wireless 802.11 b/g	Intel® Pentium® II or AMD equivalent	64 MB	256 MB	150 MB	310 MB
	Windows® XP Home ^{1 4}				128 MB			
	Windows® XP Professional ^{1 4}			AMD Opteron™ AMD Athlon™ 64 Intel® Xeon® with Intel® EM64T Intel® Pentium® 4 with Intel® EM64T or AMD equivalent	256 MB	512 MB		
	Windows® XP Professional x64 Edition ¹				512 MB	1 GB		
	Windows Vista® ¹	Intel® Pentium® 4 or equivalent 64-bit supported CPU	512 MB	1 GB	500 MB	500 MB		
Windows Server® 2003	Printing	Ethernet, Wireless 802.11 b/g	Intel® Pentium® III or AMD equivalent	256 MB	512 MB	50MB	Not Available	
Windows Server® 2003 x64 Edition								AMD Opteron™ AMD Athlon™ 64 Intel® Xeon® with Intel® EM64T Intel® Pentium® 4 with Intel® EM64T or AMD equivalent
Macintosh® Operating System	Mac OS® X 10.2.4 or greater	Printing, PC Fax send ³ , Scanning	USB ² , Ethernet, Wireless 802.11 b/g	PowerPC G4/G5, Intel® Core™ Solo/Duo, PowerPC G3 350MHz	128 MB	160 MB	80 MB	400 MB

¹ For WIA, 1200x1200 resolution. Brother Scanner Utility enables to enhance up to 19200 x 19200 dpi.

² Third party USB ports are not supported.

³ PC Fax supports black and white only.

⁴ PaperPort™ 11SE supports Microsoft® SP4 or higher for Windows® 2000 and SP2 or higher for XP.

Consumable items

Toner Cartridge Life	Standard Toner Cartridges:	
	TN-110BK (Black):	2,500 pages ¹
	TN-110C, TN-110M, TN-110Y (Cyan, Magenta, Yellow):	1,500 pages ¹
	High-Yield Toner Cartridges:	
	TN-115BK (Black):	5,000 pages ¹
	TN-115C, TN-115M, TN-115Y (Cyan, Magenta, Yellow):	4,000 pages ¹
Drum Unit Life Expectancy	DR-110CL:	Approx. 17,000 pages ²
Belt Unit	BU-100CL:	Approx. 50,000 pages ³
Waste Toner Box	WT-100CL:	Approx. 20,000 pages ⁴

¹ Approx. yields based on 5% page coverage (Letter).

² Drum yield is approximate, and may vary by type of use.

³ When printing on Letter size paper

⁴ When printing on Letter size paper at 5% print coverage for CMYK each

Ethernet wired network

Network board model name	NC-6500h
LAN	You can connect your machine to a network for Network Printing, Network Scanning, PC Fax and Remote Setup. ^{1 2}
Support for	Windows [®] 2000 Professional, Windows [®] XP, Windows [®] XP Professional x64 Edition, Windows Vista [®] , Windows Server [®] 2003 and Windows Server [®] 2003 x64 Edition ² Mac OS [®] X 10.2.4 or greater ³
Protocols	TCP/IP for IPv4: ARP, RARP, BOOTP, DHCP, APIPA (Auto IP), WINS, NetBIOS name resolution, DNS resolver, mDNS, LPR/LPD, Custom Raw Port/Port9100, IPP, IPPS, FTP server, SSL/TLS, POP before SMTP, SMTP-AUTH, Telnet, SNMPv1, HTTP/HTTPS server, TFTP client and server, SMTP client, APOP, LLTD responder, Raw Port (PC scanner), FTP client, LDAP, POP3 TCP/IP for IPv6: (Turned off as default) NDP, RA, DNS, mDNS, LPR/LPD, Custom Raw Port/Port9100, IPP, IPPS, FTP server, SSL/TLS, POP before SMTP, SMTP-AUTH, Telnet, SNMPv1, HTTP/HTTPS server, TFTP client and server, SMTP client, APOP, LLTD responder, Raw Port (PC scanner), LDAP, POP3
Network type	Ethernet 10/100 BASE-TX Auto Negotiation (Wired LAN)
Management utilities ⁴	BRAdmin Light for Windows [®] 2000 Professional, Windows [®] XP, Windows [®] XP Professional x64 Edition, Windows Vista [®] , Windows Server [®] 2003, Windows Server [®] 2003 x64 Edition and Mac OS [®] X 10.2.4 or greater BRAdmin Professional for Windows [®] 2000 Professional, Windows [®] XP, Windows [®] XP Professional x64 Edition, Windows Vista [®] , Windows Server [®] 2003 and Windows Server [®] 2003 x64 Edition Web BRAdmin for Windows [®] 2000 Professional, Windows [®] XP, Windows [®] XP Professional x64 Edition, Windows Vista [®] , Windows Server [®] 2003 and Windows Server [®] 2003 x64 Edition Client computers with a web browser supporting Java [™] .

¹ PC Fax Send for Mac[®]

² Printing only for Windows Server[®] 2003

³ Mac OS[®] X 10.2.4 or greater (mDNS)

⁴ BRAdmin Professional and Web BRAdmin are available as a download from <http://solutions.brother.com>

Ethernet wireless network

Network board model name	NC-7300w
LAN	You can connect your machine to a network for Network Printing, Network Scanning, PC Fax and Remote Setup ^{1 2} .
Support for	Windows [®] 2000 Professional, Windows [®] XP, Windows [®] XP Professional x64 Edition, Windows Vista [®] , Windows Server [®] 2003 and Windows Server [®] 2003 x64 Edition Mac OS [®] X 10.2.4 or greater ³
Protocols	TCP/IP for IPv4: ARP, RARP, BOOTP, DHCP, APIPA (Auto IP), WINS, NetBIOS name resolution, DNS resolver, mDNS, LPR/LPD, Custom Raw Port/Port9100, IPP, IPPS, FTP server, SSL/TLS, POP before SMTP, SMTP-AUTH, Telnet, SNMPv1, HTTP/HTTPS server, TFTP client and server, SMTP client, APOP, LLTD responder, Raw Port (PC scanner), FTP client, LDAP, POP3 TCP/IP for IPv6 (Turned off as default) NDP, RA, DNS, mDNS, LPR/LPD, Custom Raw Port/Port9100, IPP, IPPS, FTP server, SSL/TLS, POP before SMTP, SMTP-AUTH, Telnet, SNMPv1, HTTP/HTTPS server, TFTP client and server, SMTP client, APOP, LLTD responder, Raw Port (PC scanner), LDAP, POP3
Network type	IEEE 802.11 b/g (Wireless LAN)
Management utilities ⁴	BRAAdmin Light for Windows [®] 2000 Professional, Windows [®] XP, Windows [®] XP Professional x64 Edition, Windows Vista [®] , Windows Server [®] 2003, Windows Server [®] 2003 x64 Edition and Mac OS [®] X 10.2.4 or greater BRAAdmin Professional for Windows [®] 2000 Professional, Windows [®] XP, Windows [®] XP Professional x64 Edition, Windows Vista [®] , Windows Server [®] 2003 and Windows Server [®] 2003 x64 Edition Web BRAAdmin for Windows [®] 2000 Professional, Windows [®] XP, Windows [®] XP Professional x64 Edition, Windows Vista [®] , Windows Server [®] 2003 and Windows Server [®] 2003 x64 Edition Client computers with a web browser supporting Java [™] .

¹ PC Fax Send for Mac[®]

² Only printing for Windows Server[®] 2003

³ Mac OS[®] X 10.2.4 or greater (mDNS)

⁴ BRAAdmin Professional and Web BRAAdmin are available as a download from <http://solutions.brother.com>.

Authentication and encryption for wireless users only

Authentication method

The Brother machine supports the following methods:

- Open system

Wireless devices are allowed to access the network without any authentication.

- Shared key

A secret pre-determined key is shared by all devices that will access the wireless network. The Brother machine uses the WEP keys as the pre-determined key.

- WPA-PSK/WPA2-PSK

Enables a Wi-Fi[®] Protected Access Pre-Shared Key (WPA-PSK/WPA2-PSK), which enables the Brother wireless machine to associate with access points using TKIP for WPA-PSK or AES for WPA-PSK and WPA2-PSK (WPA-Personal).

- LEAP

Cisco[®] LEAP (Light Extensible Authentication Protocol) has been developed by Cisco Systems, Inc. and enables the Brother wireless product to associate with access points using CKIP and CMIC encryptions.

Encryption methods

Encryption is used to secure the data that is sent over the wireless network. The Brother machine supports the following encryption methods:

- WEP

By using WEP (Wired Equivalent Privacy), the data is transmitted and received with a secure key.

- TKIP

TKIP (Temporal Key Integrity Protocol) provides per-packet key mixing a message integrity check and re-keying mechanism.

- AES

AES (Advanced Encryption Standard) is Wi-Fi[®] authorized strong encryption standard.

- CKIP

The original Key Integrity Protocol for LEAP by Cisco Systems, Inc.

- CMIC

CMIC (Cisco Message Integrity Check) is the message integrity check mechanism for LEAP by Cisco Systems, Inc.

Network key

There are some rules for each security method:

■ Open system/Shared key with WEP

This key is a 64-bit or 128-bit value that must be entered in an ASCII or hexadecimal format.

- 64 (40) bit ASCII:
Uses 5 text characters. e.g. “WSLAN” (this is case sensitive).
- 64 (40) bit hexadecimal:
Uses 10 digits of hexadecimal data. e.g. “71f2234aba”
- 128 (104) bit ASCII:
Uses 13 text characters. e.g. “Wirelesscomms” (this is case sensitive)
- 128 (104) bit hexadecimal:
Uses 26 digits of hexadecimal data. e.g. “71f2234ab56cd709e5412aa2ba”

■ WPA-PSK/WPA2-PSK and TKIP or AES

Uses a Pre-Shared Key (PSK) that is 8 or more characters in length, up to a maximum of 63 characters.

■ LEAP

Uses User ID and Password.

- User ID: less than 64 characters in length.
- Password: less than 32 characters in length.

Wi-Fi Alliance certification

This wireless Ethernet multi-function print server is a Wi-Fi certified IEEE 802.11b/802.11g product by the Wi-Fi Alliance. The Wi-Fi Alliance certification ensures the interoperability of other wireless LAN products based on the IEEE 802.11 specification. For more information on the Wi-Fi Alliance and other Wi-Fi certified products, visit <http://www.wi-fi.org>.

F

Glossary

This is a comprehensive list of features and terms that appear in Brother manuals. Availability of these features depends on the model you purchased.

ADF (automatic document feeder)

The document can be placed in the ADF and scanned one page at a time automatically.

Auto Reduction

Reduces the size of incoming faxes.

Automatic fax transmission

Sending a fax without picking up the handset of the external telephone or pressing **Hook**.

Automatic Redial

A feature that enables your machine to redial the last fax number after five minutes if the fax did not go through because the line was busy.

Backup Print

Your machine prints a copy of every fax that is received and stored in memory. This is a safety feature so you will not lose messages during a power failure.

Batch Transmission

As a cost saving feature, all delayed faxes to the same fax number will be sent as one transmission.

Beeper Volume

Volume setting for the beep when you press a key or make an error.

Broadcasting

The ability to send the same fax message to more than one location.

Cancel Job

Cancels a programmed print job and clears the machine's memory.

CNG tones

The special tones (beeps) sent by fax machines during automatic transmission to tell the receiving machine that a fax machine is calling.

Coding method

Method of coding the information contained in the document. All fax machines must use a minimum standard of Modified Huffman (MH). Your machine is capable of greater compression methods, Modified Read (MR), Modified Modified Read (MMR), JBIG and JPEG, if the receiving machine has the same capability.

Communication error (or Comm. Error)

An error during fax sending or receiving, usually caused by line noise or static.

Compatibility group

The ability of one fax unit to communicate with another. Compatibility is assured between ITU-T Groups.

Contrast

Setting to compensate for dark or light documents, by making faxes or copies of dark documents lighter and light documents darker.

Delayed Fax

Sends your fax at a specified later time that day.

Distinctive Ring

A subscriber service purchased from the telephone company that gives you another telephone number on an existing telephone line. The Brother machine uses the new number to simulate a dedicated fax line.

Dual Access

Your machine can scan outgoing faxes or scheduled jobs into memory at the same time it is sending a fax or receiving or printing an incoming fax.

Easy Receive

Enables your machine to respond to CNG tones if you interrupt a fax call by answering it.

ECM (Error Correction Mode)

Detects errors during fax transmission and resends the pages of the fax that had an error.

Extension telephone

A telephone on the fax number that is plugged into a separate telephone wall jack.

External telephone

A telephone that is plugged into the EXT jack of your machine.

F/T Ring Time

The length of time that the Brother machine pseudo/double-rings (when the Receive Mode setting is Fax/Tel) to notify you to pick up a voice call that it answered.

Fax Forwarding

Sends a fax received into the memory to another pre-programmed fax number.

Fax Journal

Lists information about the last 200 incoming and outgoing faxes. TX means Transmit. RX means Receive.

Fax Receive Code

Press this code (* 5 1) when you answer a fax call on an extension or external telephone.

Fax Storage

You can store faxes in the memory.

Fax tones

The signals sent by sending and receiving fax machines while communicating information.

Fax/Tel

You can receive faxes and telephone calls. Do not use this mode if you are using a telephone answering device (TAD).

Fine resolution

Fine resolution is 203 × 196 dpi. It is used for small print and graphs.

Gray scale

The shades of gray available for copying and faxing photographs.

Group number

A combination of One-Touch and Speed-Dial numbers that are stored on a One-Touch key or in a Speed-Dial location for Broadcasting.

Help list

A printout of the complete Menu table that you can use to program your machine when you do not have the User's Guide with you.

Journal Period

The pre-programmed time period between automatically printed Fax Journal Reports. You can print the Fax Journal on demand without interrupting the cycle.

LCD (liquid crystal display)

The display screen on the machine that shows interactive messages during On-Screen Programming and shows the date and time when the machine is idle.

Manual fax

When you lift the handset of your external telephone or press **Hook** so you can hear the receiving fax machine answer before you press **Black Start** or **Color Start** to begin transmission.

Menu mode

Programming mode for changing your machine's settings.

OCR (optical character recognition)

The bundled ScanSoft™ PaperPort™ 11SE with OCR or Presto!® PageManager® software application converts an image of text to text you can edit.

One-Touch

Keys on the machine's control panel where you can store numbers for easy dialing. You can store a second number on each key if you press **Shift** and the One-Touch key together.

Out of Paper Reception

Receives faxes into the machine's memory when the machine is out of paper.

Overseas Mode

Makes temporary changes to the fax tones to accommodate noise and static on overseas telephone lines.

Paging

This feature enables your machine to call your pager when a fax is received into its memory.

Pause

Allows you to place a 3.5 second delay in the dialing sequence stored on One-Touch keys and Speed-Dial numbers. Press **Redial/Pause** as many times as needed for longer pauses.

PictBridge

Allows you to print photos directly from your PictBridge compatible digital camera at high resolution for photo quality printing.

Polling

The process of a fax machine calling another fax machine to retrieve waiting fax messages.

Pulse (Canada only)

A form of rotary dialing on a telephone line.

Quick Dial List

A listing of names and numbers stored in One-Touch and Speed-Dial memory, in numerical order.

Real Time Transmission

When memory is full, you can send faxes in real time.

Remaining jobs

You can check which programmed fax jobs are waiting in the memory and cancel the jobs individually.

Remote Access Code

Your own four-digit code (---*) that allows you to call and access your machine from a remote location.

Remote Retrieval Access

The ability to access your machine remotely from a touch tone telephone.

Resolution

The number of vertical and horizontal lines per inch.

Ring Delay

The number of rings before the machine answers in **Fax Only** and **Fax/Tel** modes.

Ring Volume

Volume setting for the machine's ring.

Scanning

The process of sending an electronic image of a paper document into your computer.

Search

An electronic, alphabetical listing of stored One-Touch, Speed-Dial and Group numbers.

Speed-Dial

A pre-programmed number for easy dialing. You must hold down **Shift** as you press **Search/Speed Dial**, then enter the three-digit Speed-Dial location and press **Black Start** or **Color Start** to begin the dialing process.

Station ID

The stored information that appears on the top of faxed pages. It includes the sender's name and fax number.

TAD (telephone answering device)

You can connect an external device or answering machine to the EXT. jack of your machine.

**Telephone Answer Code
(Fax/Tel mode only)**

When the machine answers a voice call, it pseudo/double-rings. You can pick up at an extension telephone by pressing this code (# 5 1).

Temporary settings

You can select certain options for each fax transmission and copy without changing the default settings.

Tone

A form of dialing on the telephone line used for Touch Tone telephones.

Transmission

The process of sending faxes over the telephone lines from your machine to the receiving fax machine.

Transmission Verification Report

A report for each transmission, that shows its date, time and number.

User Settings List

A printed report that shows the current settings of the machine.

G

Index

- A**
- Accessories and supplies iii
 - ADF (automatic document feeder)34
 - using20
 - Answering machine (TAD)
 - connecting54
 - Apple® Macintosh®
 - See Software User's Guide on the CD-ROM.
 - Automatic
 - fax receive45
 - easy receive47
 - fax redial59
- B**
- Belt unit183
 - Broadcasting36
 - canceling37
 - setting up groups for63
 - Brother
 - accessories and supplies iii
 - Brother numbers i
 - Customer Service ii
 - FAQs (frequently asked questions) i
 - product support ii
 - service centers ii
 - warranties iv, v, vii
- C**
- Canceling
 - broadcast in process37
 - fax jobs in memory42
 - jobs awaiting redial42
 - print jobs8
 - remote fax options68
 - Cleaning
 - corona wire158
 - drum unit161
 - laser scanner window154
 - scanner153
 - Connecting
 - external TAD (answering machine)53
 - external telephone57
 - two-line external TAD or telephone55
 - Consumable items169
 - Control panel overview 6
 - ControlCenter2 (for Macintosh®)
 - See Software User's Guide on the CD-ROM.
 - ControlCenter3 (for Windows®)
 - See Software User's Guide on the CD-ROM.
 - Copy
 - brightness 83
 - color saturation 84
 - contrast7, 78, 84
 - duplex7, 81, 82
 - Enlarge/Reduce key 79
 - enter copy mode 78
 - keys 7, 79
 - multiple 78
 - N in 1 (page layout) 7, 80
 - out of memory 85
 - quality 7, 79
 - single 78
 - sort (ADF only) 7, 83
 - temporary settings 79
 - tray selection 7, 85
 - using ADF20, 81, 83
 - using scanner glass21, 80, 81
 - Cordless telephone (non-Brother) 57
 - Cover page 38
 - custom comments 38
 - for all faxes 39
 - for next fax only 38
 - printed form 39
 - Custom Ringing 51
- D**
- Data Ident-A-Call 51
 - Delayed batch transmission 42
 - Dialing
 - a pause 60
 - access codes and credit card numbers 64
 - automatic fax redial 59
 - groups (broadcasting) 36
 - manual 58
 - one-touch 58
 - speed-dial 58
 - using the Search key 59

Direct	
Direct key	8
Direct print	91
Direct key	8, 92
specification	231
Distinctive ring	51
setting ring pattern	52
turning off	53
Document	
how to load	20
ADF	20
scanner glass	21
jam	140
Drum unit	
checking (remaining life)	203
cleaning	158, 161
replacing	177
Dual access	40
Duplex (2-sided)	
copying	81, 82
printing	209
from USB flash memory drive	92
scanning	209
troubleshooting	117, 137, 141, 150
Duplex key (2-sided)	7, 34, 81, 82

E

Enlarge/Reduce key	79
Envelopes	11, 12, 14, 17, 19
Equalization	132
Error messages on LCD	133
Change Parts	
Belt Unit	183
Drum	177
Waste Toner Box	188
Comm. Error	134
Init Unable XX	135
No Paper	135
Not Registered	58
Out of Memory	136
Print Unable XX	136
Scan Unable XX	137
Toner Life End	172
Toner Low	172
Waste Toner Full	188
Extension telephone, using	56, 57
External telephone, connecting	57

F

Fax codes	
changing	57, 69
fax receive code	56, 57
remote access code	69
telephone answer code	56, 57
Fax forwarding	
changing at the machine	65
changing remotely	70, 71
programming a number	65
Fax storage	66
printing from memory	49
turning off	68
Fax, stand-alone	
receiving	44
at end of conversation	49
backup print	65, 67, 68, 140
easy receive	47
fax forwarding	65, 71
fax receive stamp	49
from extension telephone	56, 57
paging	66
polling receive	72
reducing to fit on paper	48
retrieving from a remote site	70, 71
ring delay, setting	46
sequential polling	72
telephone line interference	132
sending	22, 34
at end of conversation	43
broadcasting	36
canceling from memory	42
contrast	39
delayed batch	42
delayed fax	41
from ADF	34
from memory (dual access)	40
from scanner glass	35
manual	43
overseas	41
polled transmit	73
real time transmission	41
resolution	40
telephone line interference	132

Fax/Tel mode	
answering at extension	
telephones	56, 57
easy receive	47
F/T ring time (double-ring)	46
fax receive code	56, 57
receiving faxes	56
ring delay	46
telephone answer code	56, 57
Folio	12, 23, 80
Function Lock	29

G

Gray scale	227, 229
Groups for broadcasting	63

H

HELP	75
Help List	75
LCD messages	204
Menu Table	204, 206
using menu keys	204
Hook key	7, 56, 57

I

Ident-A-Call	51
Ident-A-Ring	51

J

Jacks	
convert to RJ11 jack	
triplex adapter	55
EXT	
external telephone	57
TAD (answering machine)	53
Jams	
document	140
paper	141
Job Cancel key	8, 117

L

Labels	11, 12, 16, 19
LCD (liquid crystal display)	6, 204
contrast	27
Help List	75
LDAP	
See Network User's Guide on the CD-ROM.	

M

Machine information	
checking remaining life of parts	203
page counters	202
status LED	9
Macintosh®	
See Software User's Guide on the CD-ROM.	
Maintenance, routine	152
checking the remaining life of parts	203
replacing	
belt unit	183
drum unit	177
toner cartridge	172
waste toner box	188
Manual	
dialing	58
receive	44
transmission	43
Memory	
adding DIMM (option)	112
installing	113
storage	204
Menu Table	204, 206
using menu keys	204
Mode, entering	
copy	78
fax	34
scan	7
Multi-line connections (PBX)	56

N

N in 1 (page layout)	80
Network	
faxing	
See Software User's Guide on the CD-ROM.	
printing	
See Network User's Guide on the CD-ROM.	
scanning	
See Software User's Guide on the CD-ROM.	

O

One-touch	
changing	62
setting up	60
using	58
Out of Memory	
message	43, 85, 90, 93, 136

P

Packing and shipping the machine	194
Page layout (N in 1)	80
Paging	66
programming your pager number	66
Paper	11, 226
how to load	17
jam	141
size	11
size of document	20, 228, 229
type	11, 22
PaperPort™ 11SE with OCR	
See Software User's Guide on the CD-ROM and Help in the PaperPort™ 11SE application to access How-to-Guides.	
PC Fax	
See Software User's Guide on the CD-ROM.	
Personalized Ring	51
PictBridge	
DPOF printing	90
specification	231

Polling	
polled transmit	73
polling receive	72
sequential polling	72
Power failure	204
Print	
difficulties	114
Direct key	8
drivers	230
fax from memory	49
Job Cancel key	8, 117
keys	8
paper jams	141
quality	121
reports	75
resolution	230
Secure key	8
specifications	230
Printing	
See Software User's Guide on the CD-ROM.	
Programming your machine	204

Q

Quality (copying)	79
Quick-dial	60
access codes and credit card	
numbers	64
broadcasting	36
using groups	36
group dial	
changing	62
setting up groups for broadcasting	63
one-touch dial	
changing	62
custom scan profile	60
setting up	60
using	58
search	59
speed-dial	
changing	62
custom scan profile	60, 61
setting up	61
using	58

R

Redial/Pause key	59, 60, 64
Reducing	
copies	79
incoming faxes	48
Remote retrieval	69
access code	69
commands	71
getting your faxes	70
Remote setup	
See Software User's Guide on the CD-ROM.	
Replacing	
belt unit	183
drum unit	177
toner cartridge	172, 173
waste toner box	188
Reports	74, 75
Fax Journal	74, 75
journal period	74
Help List	75
how to print	75
Network Configuration	75
Quick-Dial List	75
Transmission Verification	74
User Settings	75
Resolution	
copy	228
fax (standard, fine, superfine, photo)	40, 227
print	230
scan	229
setting for next fax	40
Resolution key	7, 40
Restricted users	31
Ring delay, setting	46
RingMaster	51

S

Safety instructions	106
Scanner glass, using	21
Scanning	
See Software User's Guide on the CD-ROM.	
Search/Speed Dial key	58, 59, 63
Secure key	8

Security

Secure function lock	
administrator password	30
Public user	30
restricted users	31
Secure key	8
Setting lock	28
Serial number	
how to find	See inside front cover
Service centers	ii
Shipping the machine	194
SimpleBiz Fax & Alternate Number	
Ringing	51
Sleep time	26
Smart Ring	51
Sort	83
Speed-dial	
changing	62
setting up	61
using	58
Status LED	6, 9

T

TAD (telephone answering device),	
external	44, 45, 55
connecting	53, 54
recording OGM	54
with two-line jack	55
Teen Ring	51
Telephone line	
connections	54
difficulties	115
interference	132
multi-line (PBX)	56
roll over lines	54
two-line telephone system	55
Temporary copy settings	79
Text, entering	222
Toner cartridge, replacing	172
Toner save	26
Tray selection	85
Tray Select key	7
Tray use, setting	
copy	23
fax	24
print	24

Troubleshooting	114
document jam	140
error messages on LCD	133
if you are having difficulty	
copy quality	116
incoming calls	115
network	118
paper handling	118
print quality	118, 121
printing	114, 116
scanning	117
software	117
telephone line	132
paper jam	141
Two-line telephone system	55

V

Volume, setting	
beeper	25
ring	25
speaker	25

W

Warranties	iv
Canada	vii
Notice-Disclaimer	iv
USA	v
Waste toner box	188
Windows®	
See Software User's Guide on the CD-ROM.	
Wireless Network	
See Software User's Guide and Network User's Guide on the CD-ROM.	
World Wide Web	i



EQUIPMENT ATTACHMENT LIMITATIONS (Canada only)

NOTICE

This product meets the applicable Industry Canada technical specifications.

NOTICE

The Ringer Equivalence Number is an indication of the maximum number of devices allowed to be connected to a telephone interface. The termination on an interface may consist of any combination of devices subject only to the requirement that the sum of the RENs of all the devices does not exceed five.

Brother International Corporation
100 Somerset Corporate Boulevard
P.O. Box 6911
Bridgewater, NJ 08807-0911 USA

Brother International Corporation (Canada) Ltd.
1 rue Hôtel de Ville,
Dollard-des-Ormeaux, QC, Canada H9B 3H6

brother®

**Visit us on the World Wide Web
<http://www.brother.com>**

These machines are made for use in the USA and Canada only. We cannot recommend using them overseas because it may violate the Telecommunications Regulations of that country and the power requirements of your machine may not be compatible with the power available in foreign countries. **Using USA or Canada models overseas is at your own risk and may void your warranty.**